

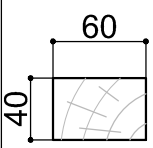

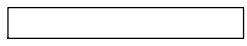

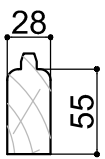

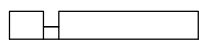

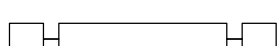

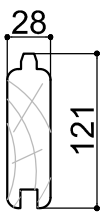

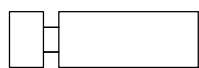

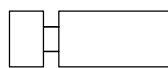
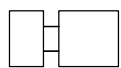
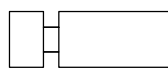
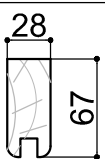
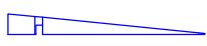
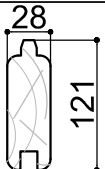

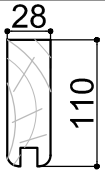
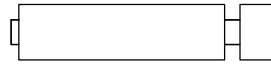

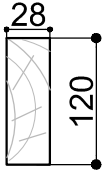
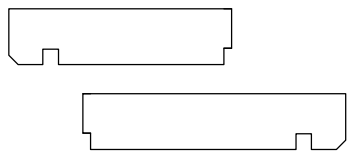
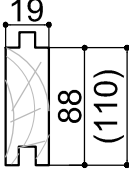
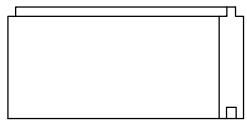
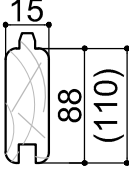
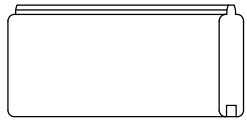
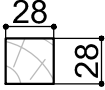
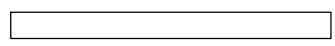
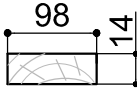

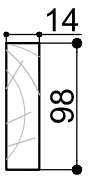
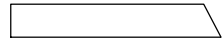
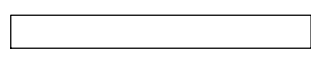

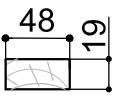

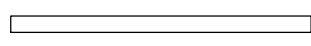
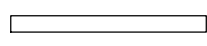
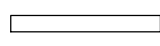
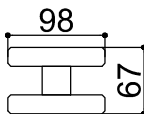
Dim.	Skizze	Pos.	Länge (mm)	Stck.	Name	Ref.
		①	2800	2	Fundamentbalken	283001
		②	2100	6	Fundamentbalken	283007
		③	2900	1	Fundamentbalken	283069
		④	365	1	Fundamentbalken	283129
		⑤	692	2	Front Brett	280254
		⑥	2980	1	Zurück Brett	280006
		⑫	2865	1	Zurück Brett	280258
		⑦	2400	33	Seiten Brett	280019
		⑧	2980	15	Zurück Brett	280007
		⑨	692	34	Front Brett	280255
		⑩	2865	15	Zurück Brett	280259
		⑪	515	15	Seiten Brett	280089
		⑬	285	1	Front Brett	280077
		⑭	515	1	Front Brett	280089
		⑰	666	3	Seiten Brett	282059
		⑯	1550	3	Seiten Brett	282060
		⑮	2400	3	Seiten Brett	282061
		⑱	2880	2	Front/zurück Brett	281062
		⑲	3000	2	Front/zurück Brett	281064

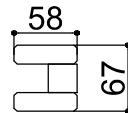
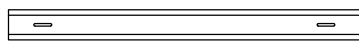
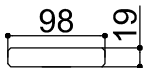
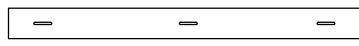
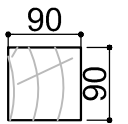
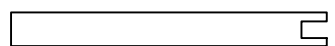
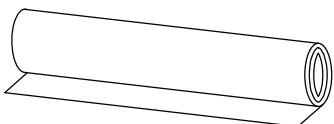
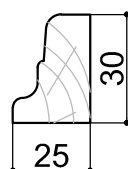
Dim.	Skizze	Pos.	Länge (mm)	Stck.	Name	Ref.
		20	2880	3	Sparren	284080
		21	3000	3		284082
		22	2740	25 (20)	Bodenbretter	283503
		23	2450	67 (54)	Dachbretter	284538
		24	1470	4	Wind Brett	286084
		25	1470	4	Wind Brett	286083
		26	2500	2	Windbretter	285082
		27	2900	1	Windbretter	285085
		28	3018	1	Windbretter	285071
		29	250	1	Wind Brett	287132
		30	2470	2	Leiste	286533
		31	3018	1	Leiste	286534
		32	2900	1	Leiste	286537

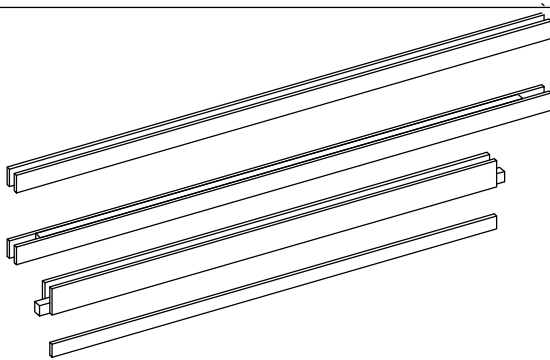
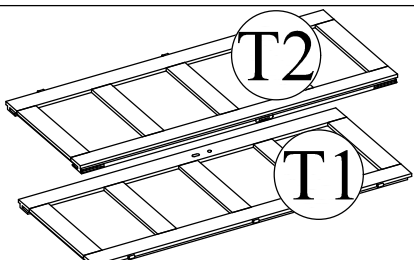
Dim.	Skizze	Pos.	Länge (mm)	Stck.	Name	Ref.
		33	1780	1	Bretter	287139
		34	1670	1	Bretter	287140
		35	1780	1	Bretter	287141
		36	1700	1	Unterstützung	287142
		37	6000	3	Bitume	285523
		38	2750	1	Bodenleiste	283302
		39	2170	2	Bodenleiste	283291
		40	555	2	Bodenleiste	283311
	TR1	1960	1	Türrahmen links	289242	
	TR2	1960	1	Türrahmen rechts	289243	
	TR3	1580	1	Über Türrahmen	289244	
	TR4	1510	1	Türstufe	289245	
	T1	1850x 765	1	Tür	289019 T1	
	T2	1850x 765	1	Tür	289019 T2	

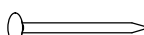
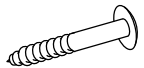
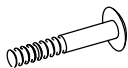
	Pos.	Dim	Quant.
		Ø3.5 x 40	82
		Ø5.0 x 100	30
		Ø3.5 x 60	4
		Ø2.0 x 40	350
		Ø2.0 x 50	150
		Ø2.0 x 16	70
		6.3 x 80	2
		M6.0 x 80	9
		Ø6.0	20
		M6	9

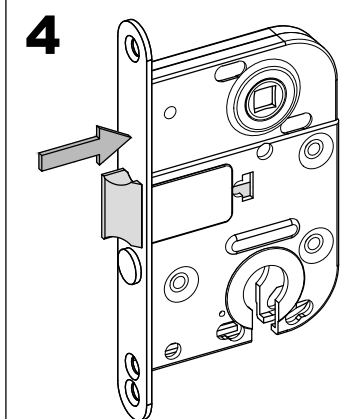
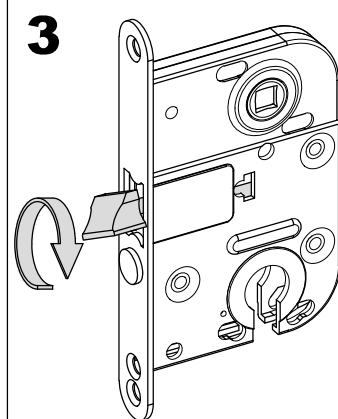
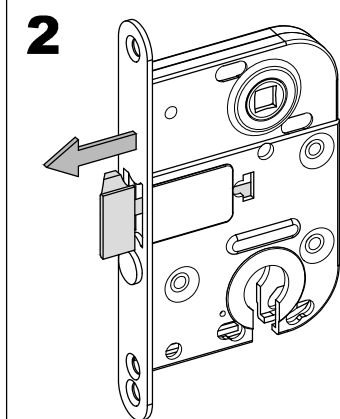
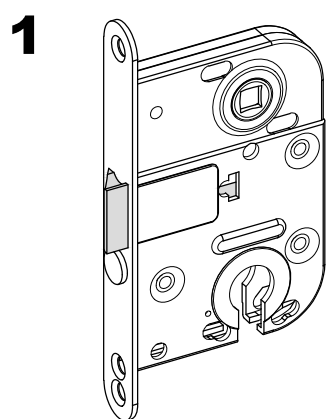
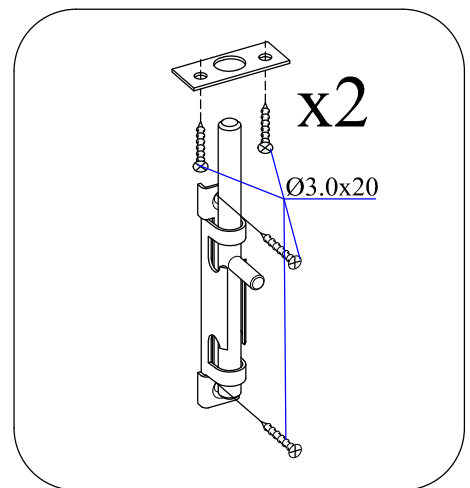
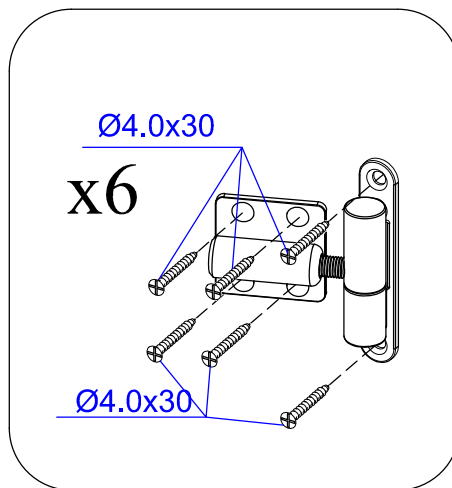
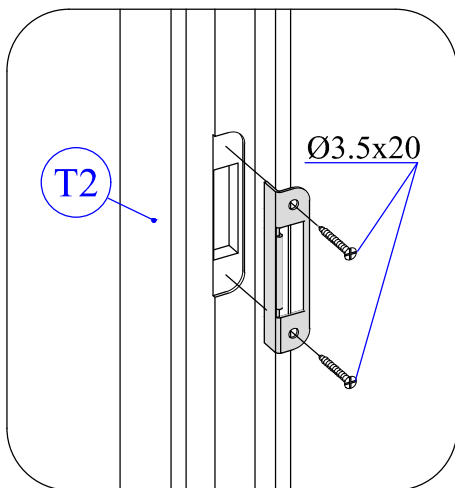
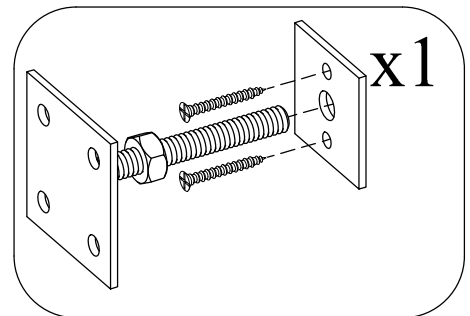
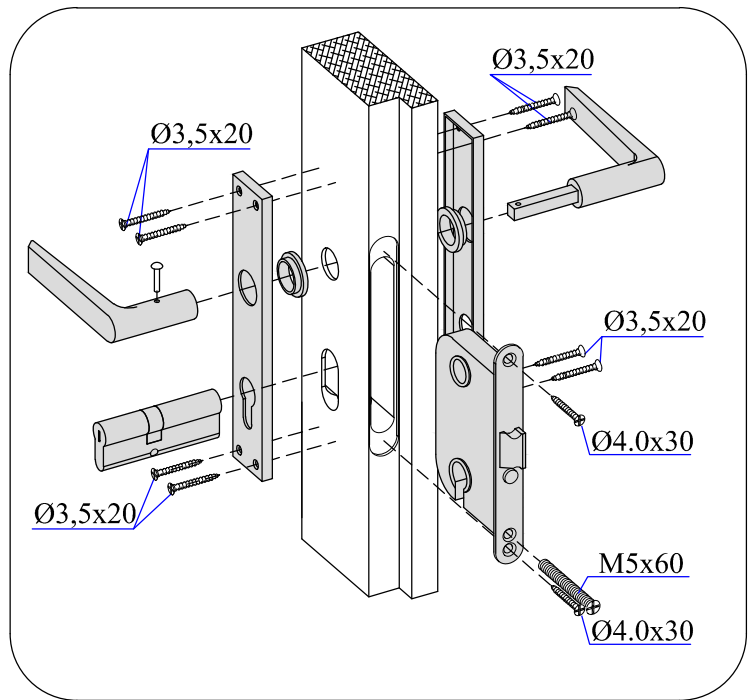

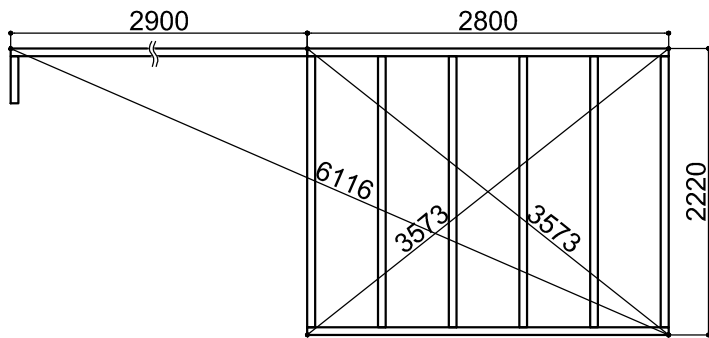

1

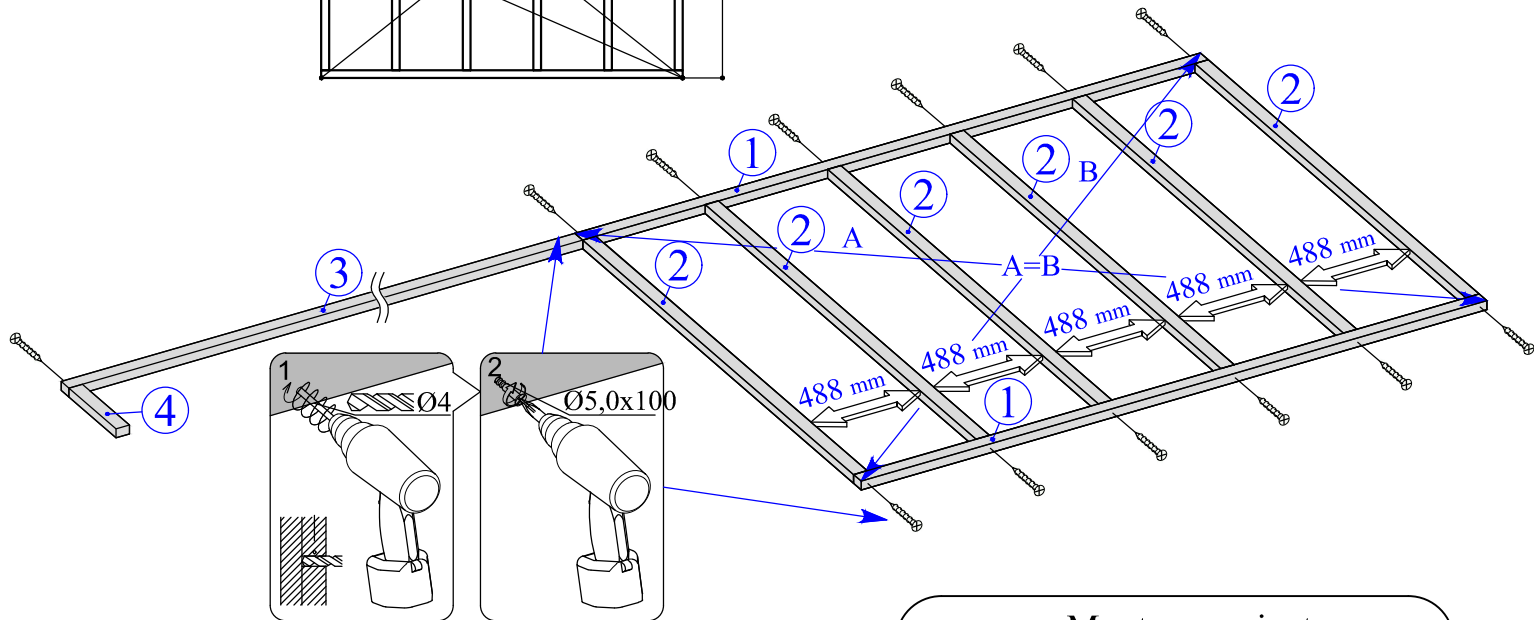

Montage variante
Assembling variant
Des option de montage

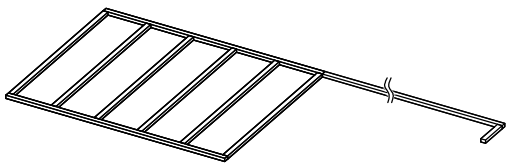

Montage variante
Assembling variant
Des option de montage

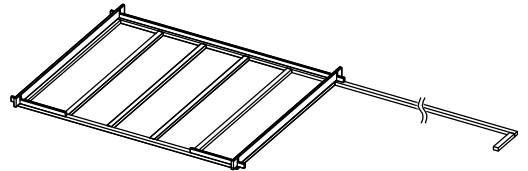

2

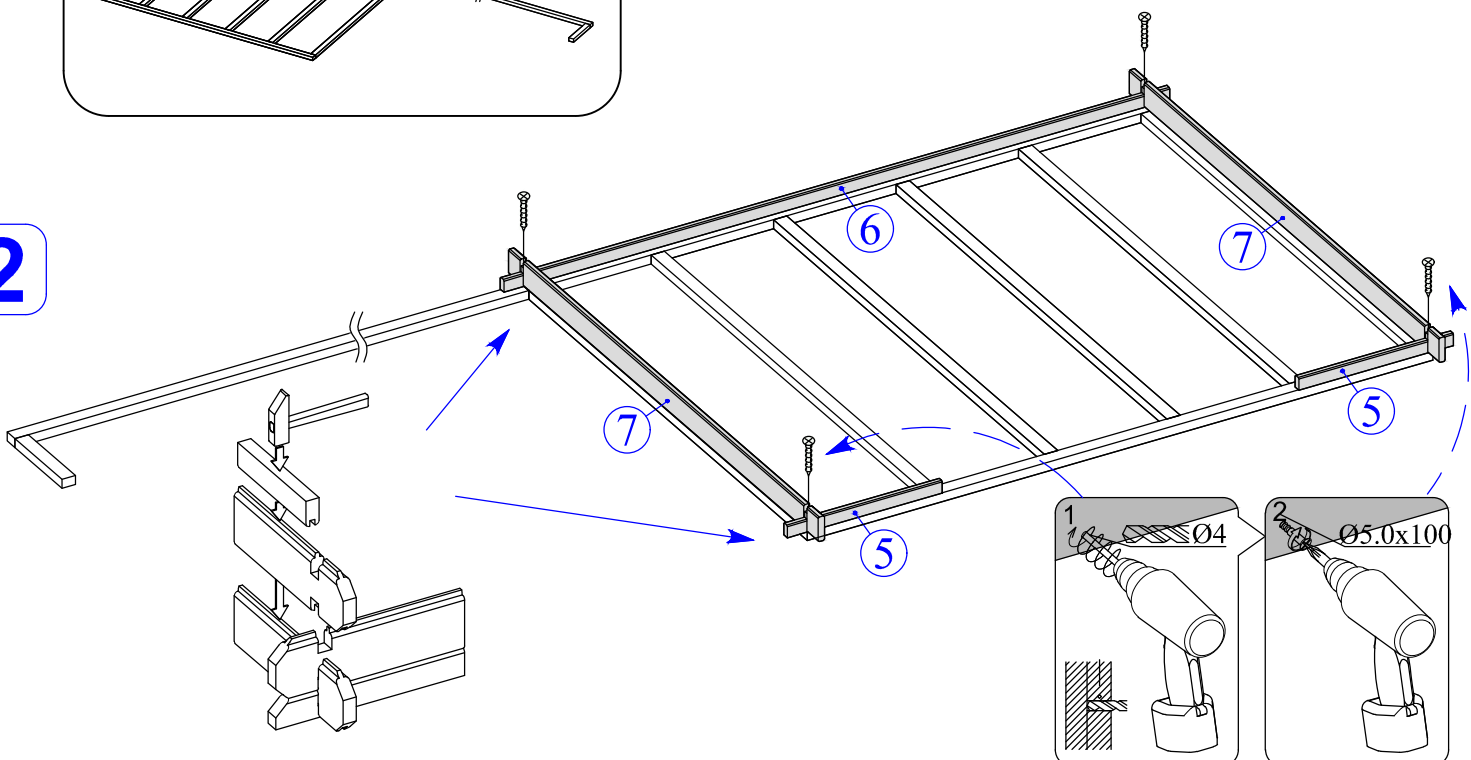

3

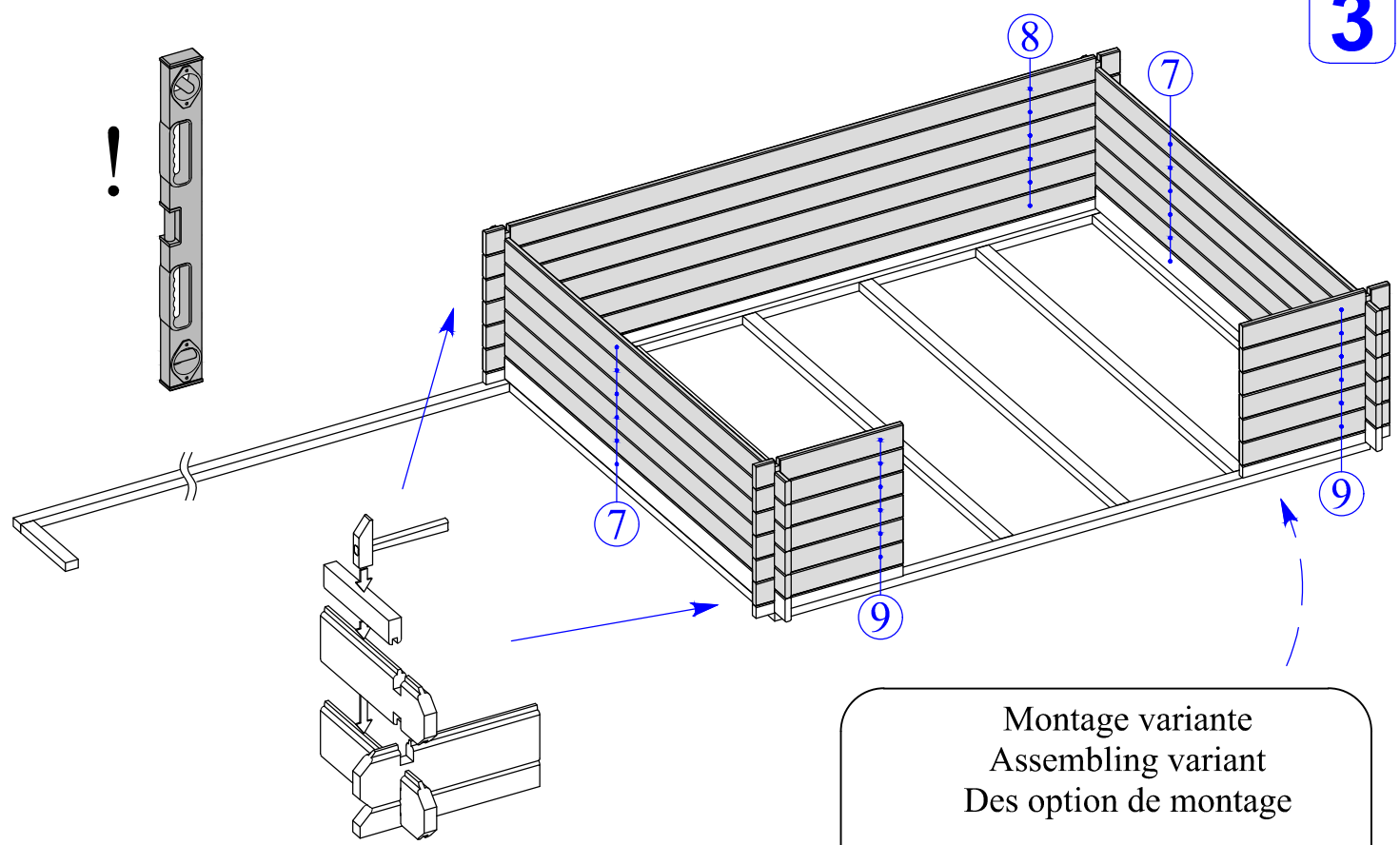

Montage variante
Assembling variant
Des option de montage

An inset diagram showing an alternative assembly option for the slatted panels, with a dashed line indicating a different connection point.

4

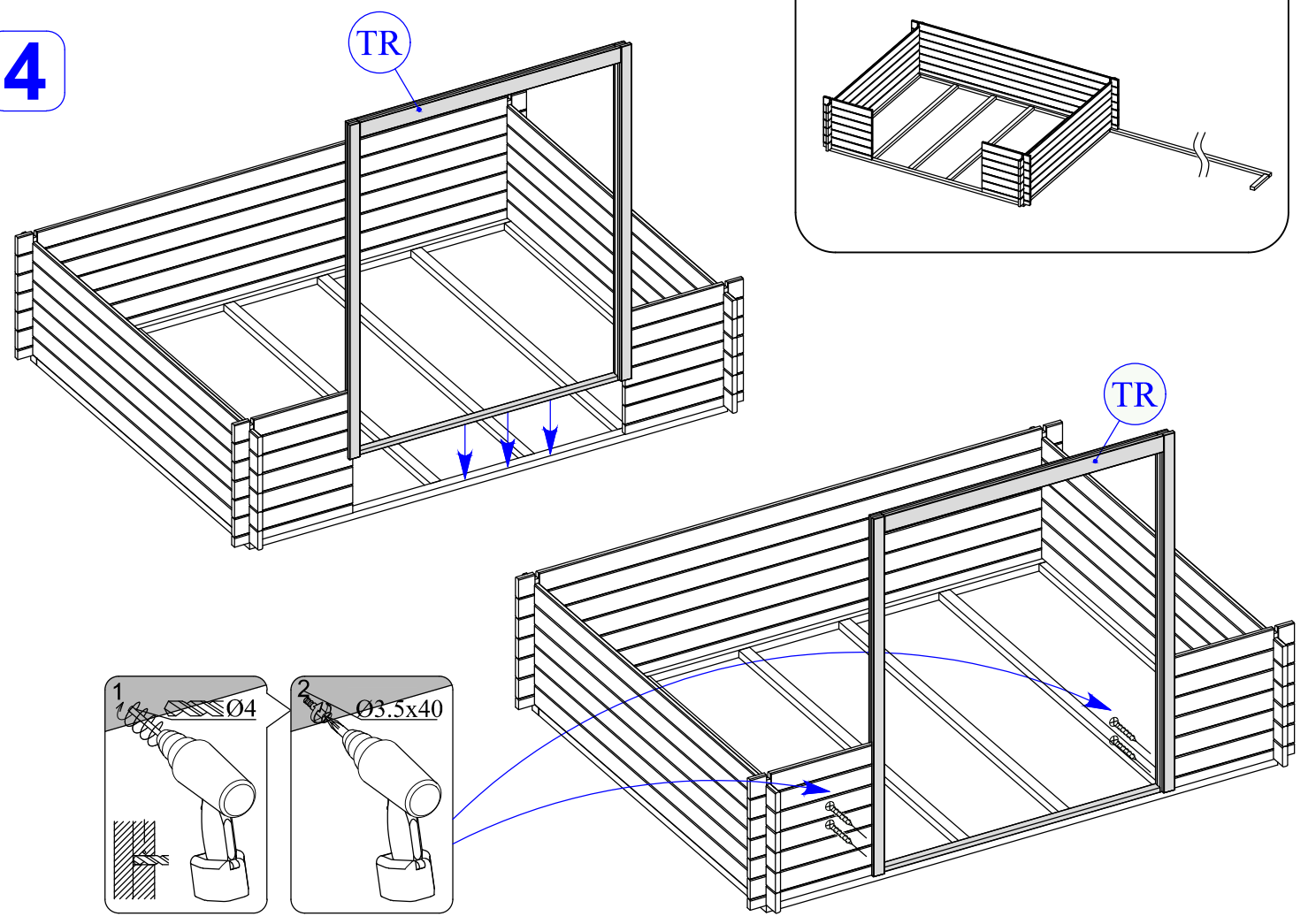

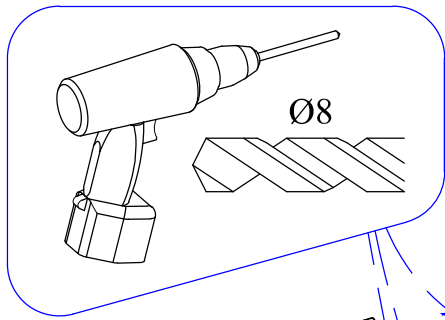

6

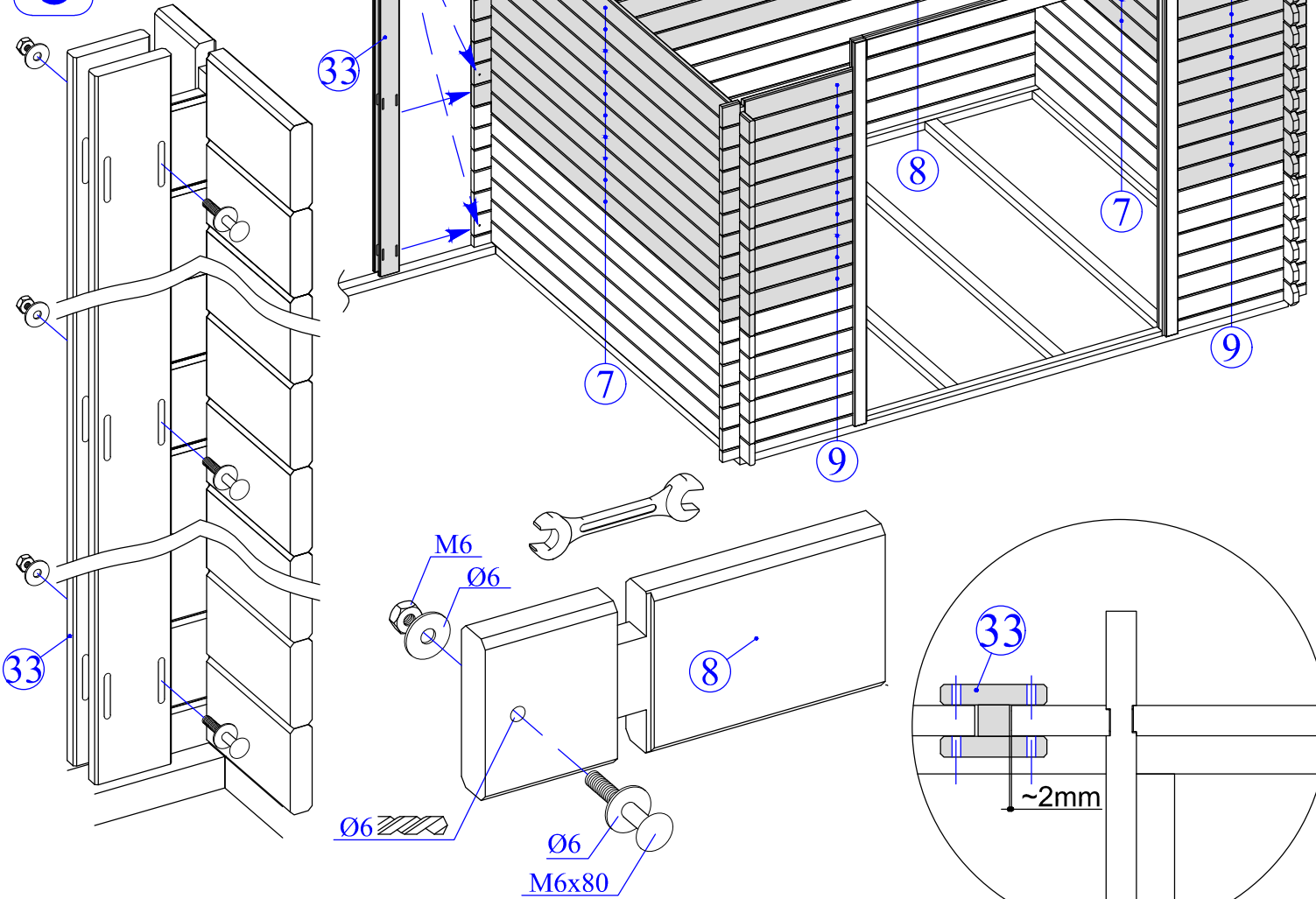

Montage variante
 Assembling variant
 Des option de montage

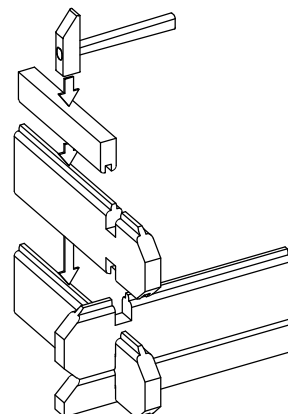
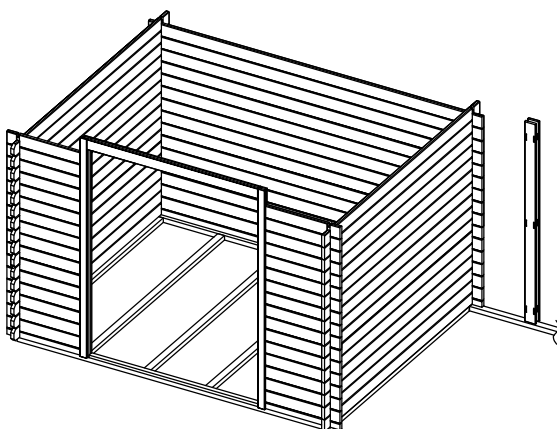

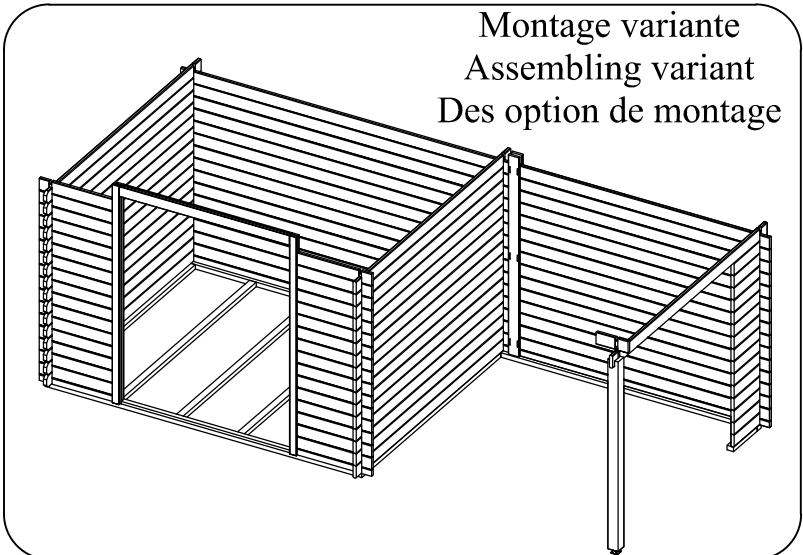
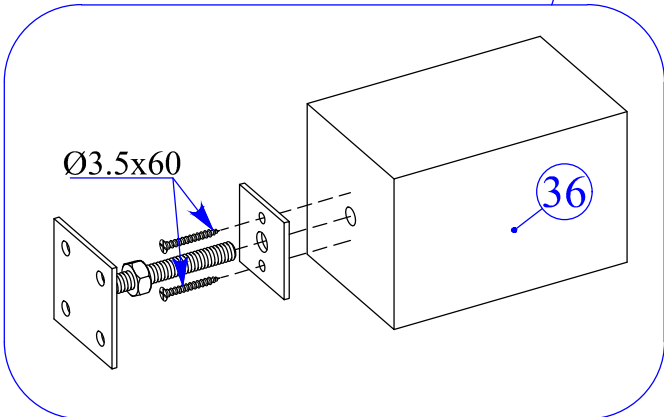
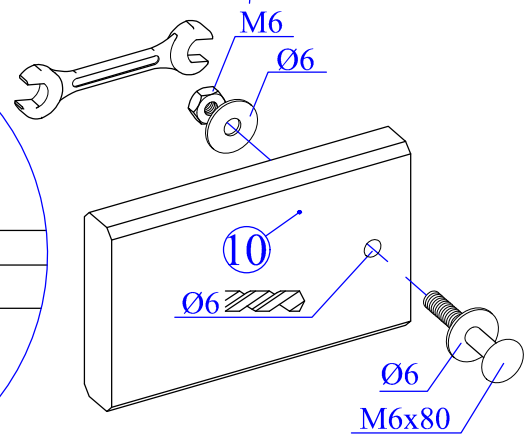
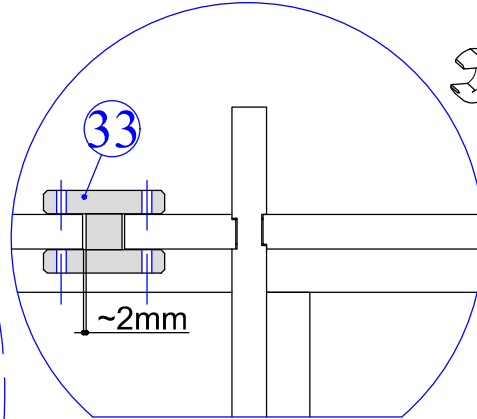
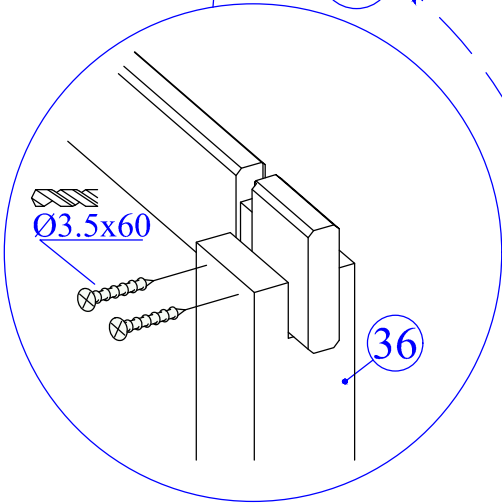
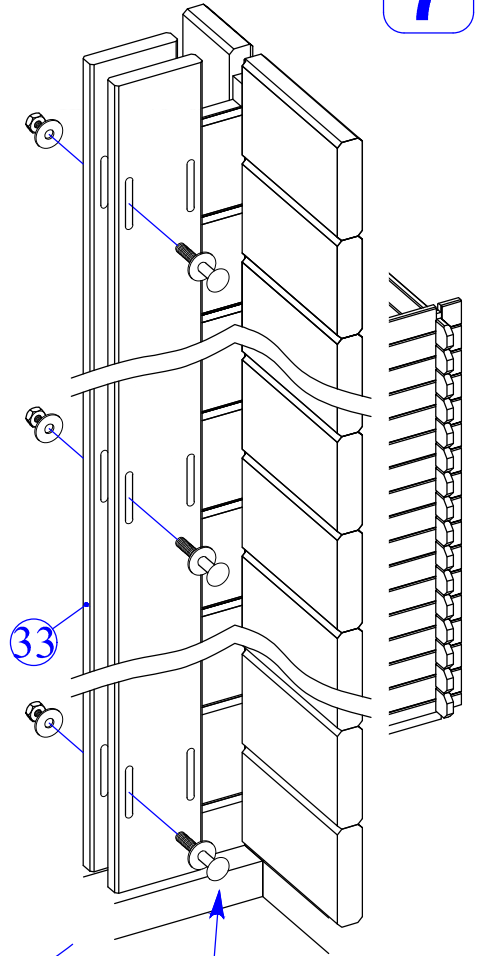
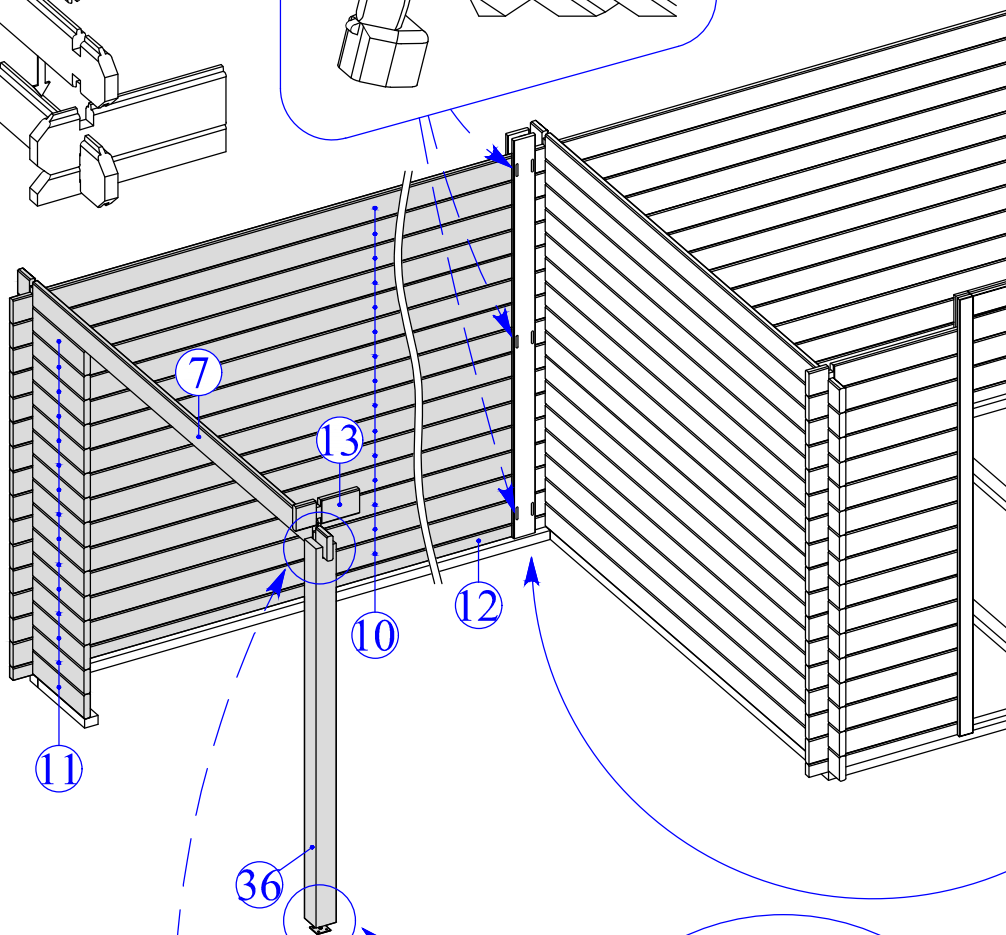
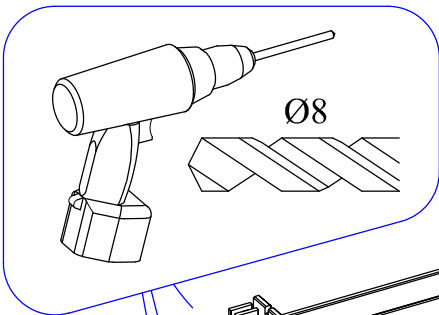
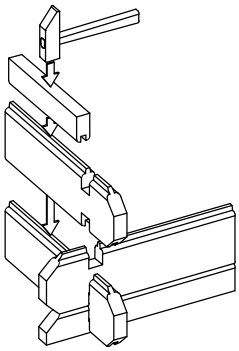

Montage variante
Assembling variant
Des option de montage

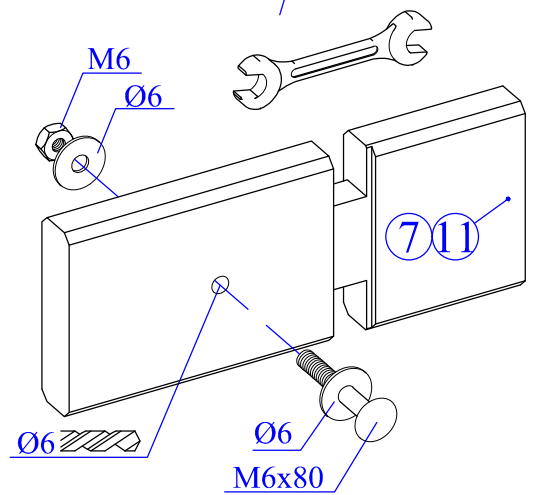
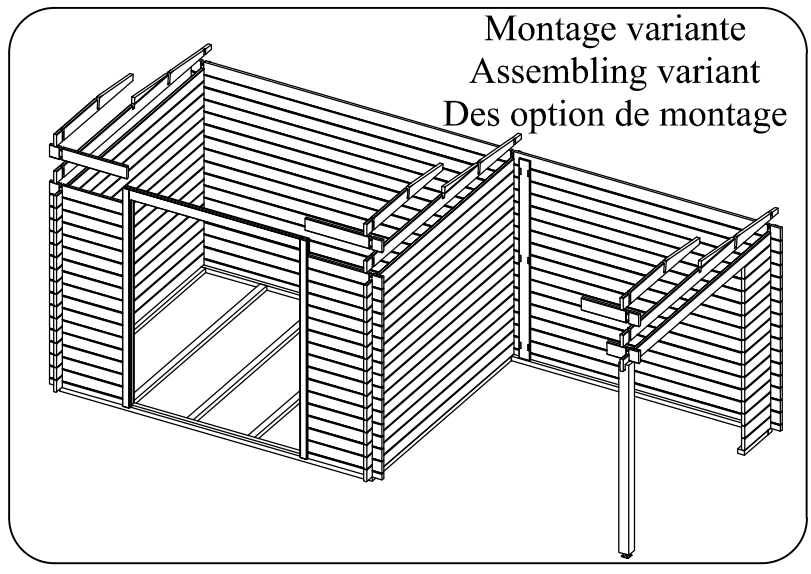
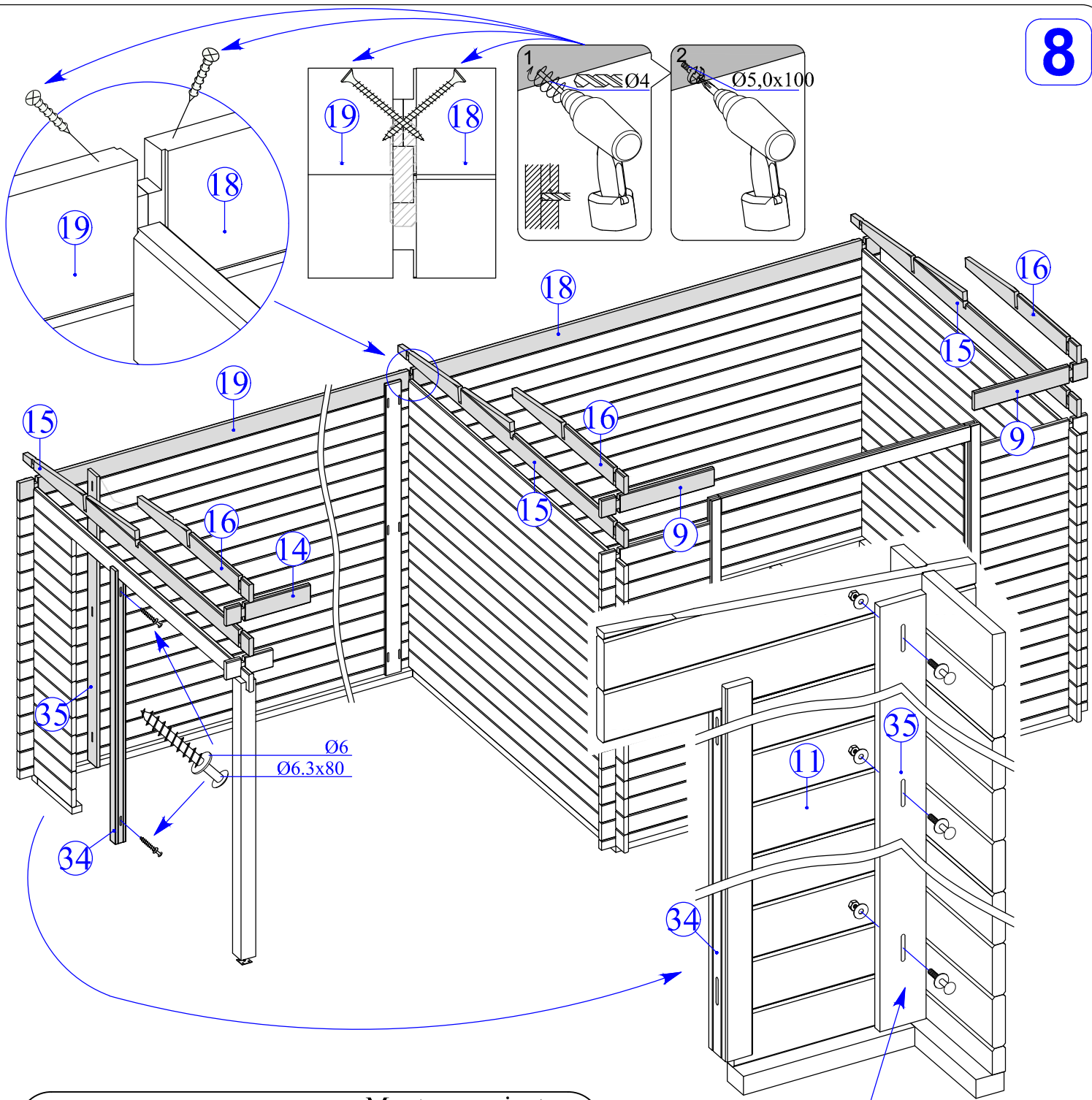

9

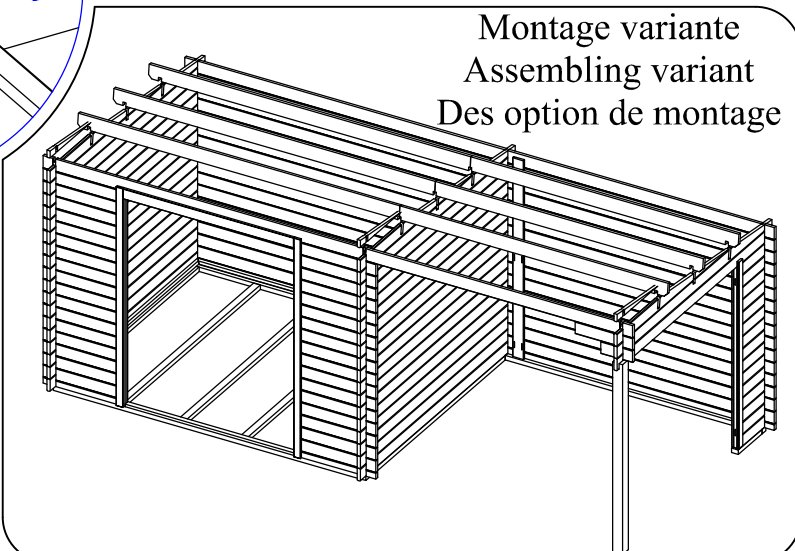
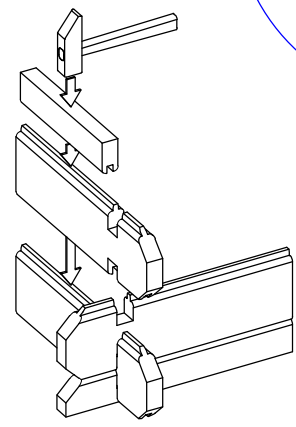
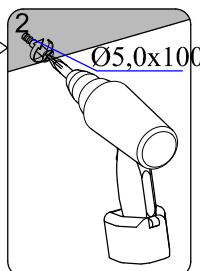
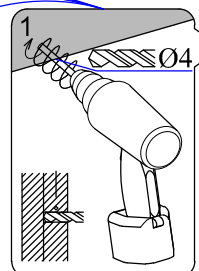
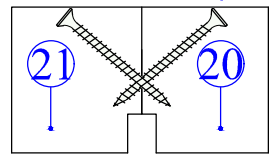
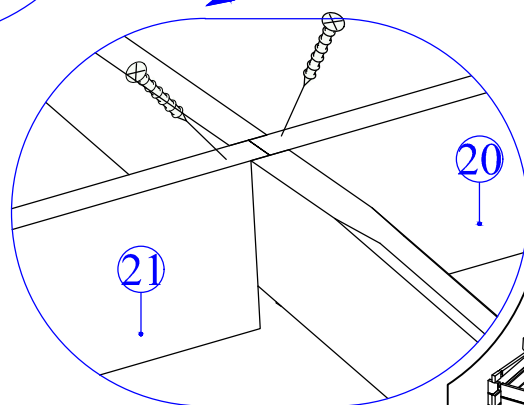
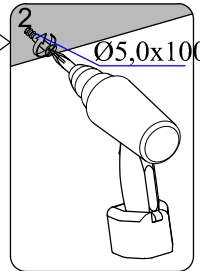
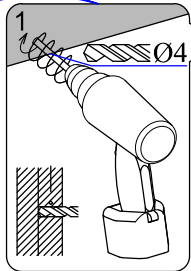
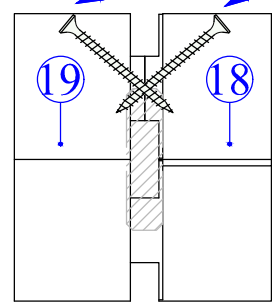
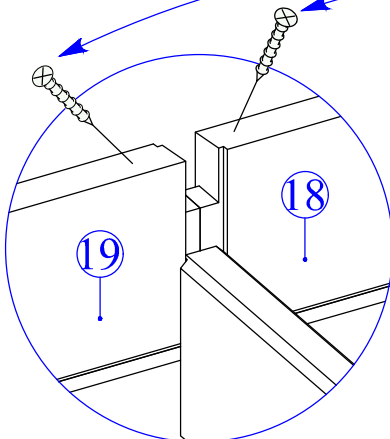
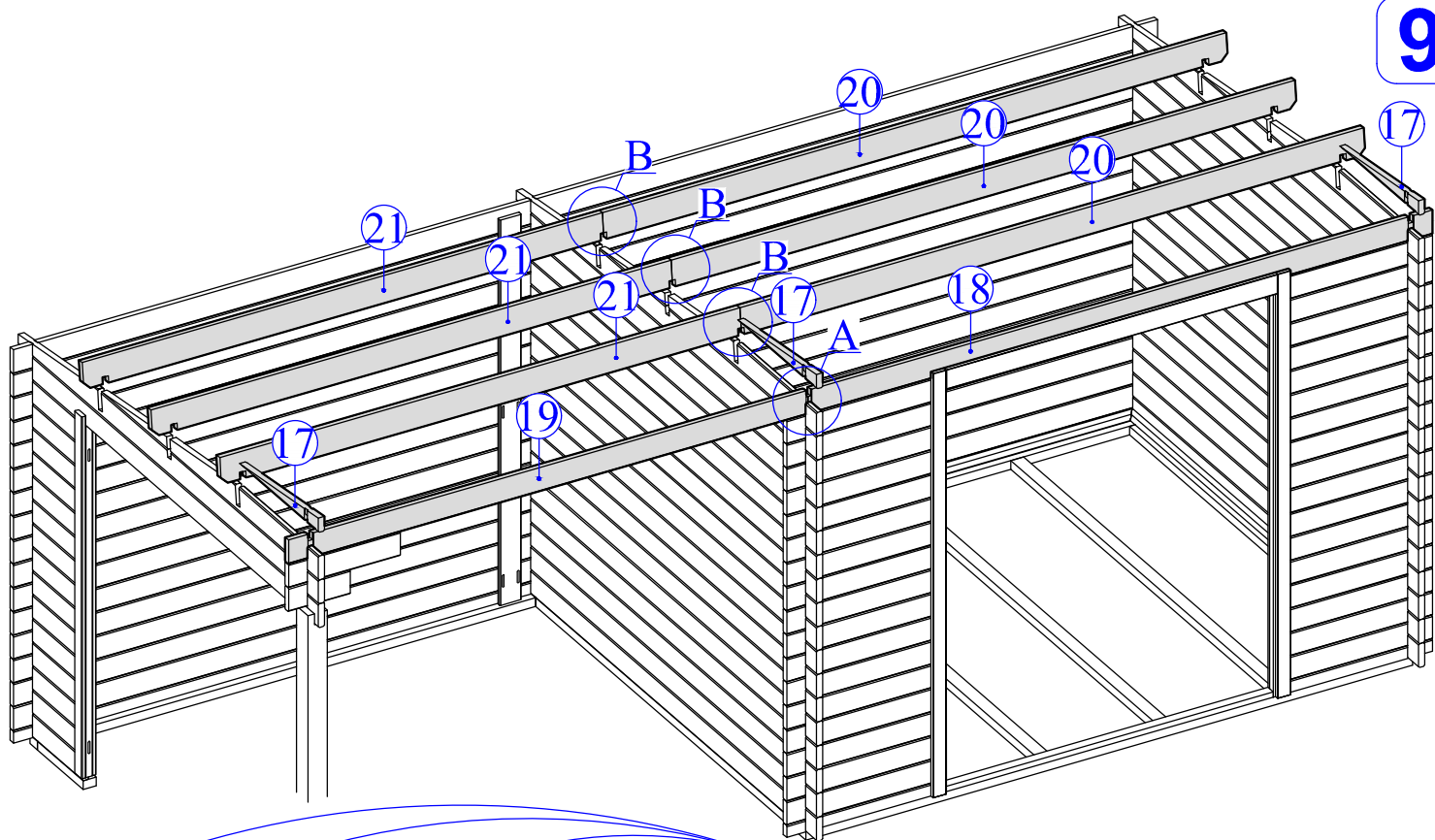

Montage variante
Assembling variant
Des option de montage

10

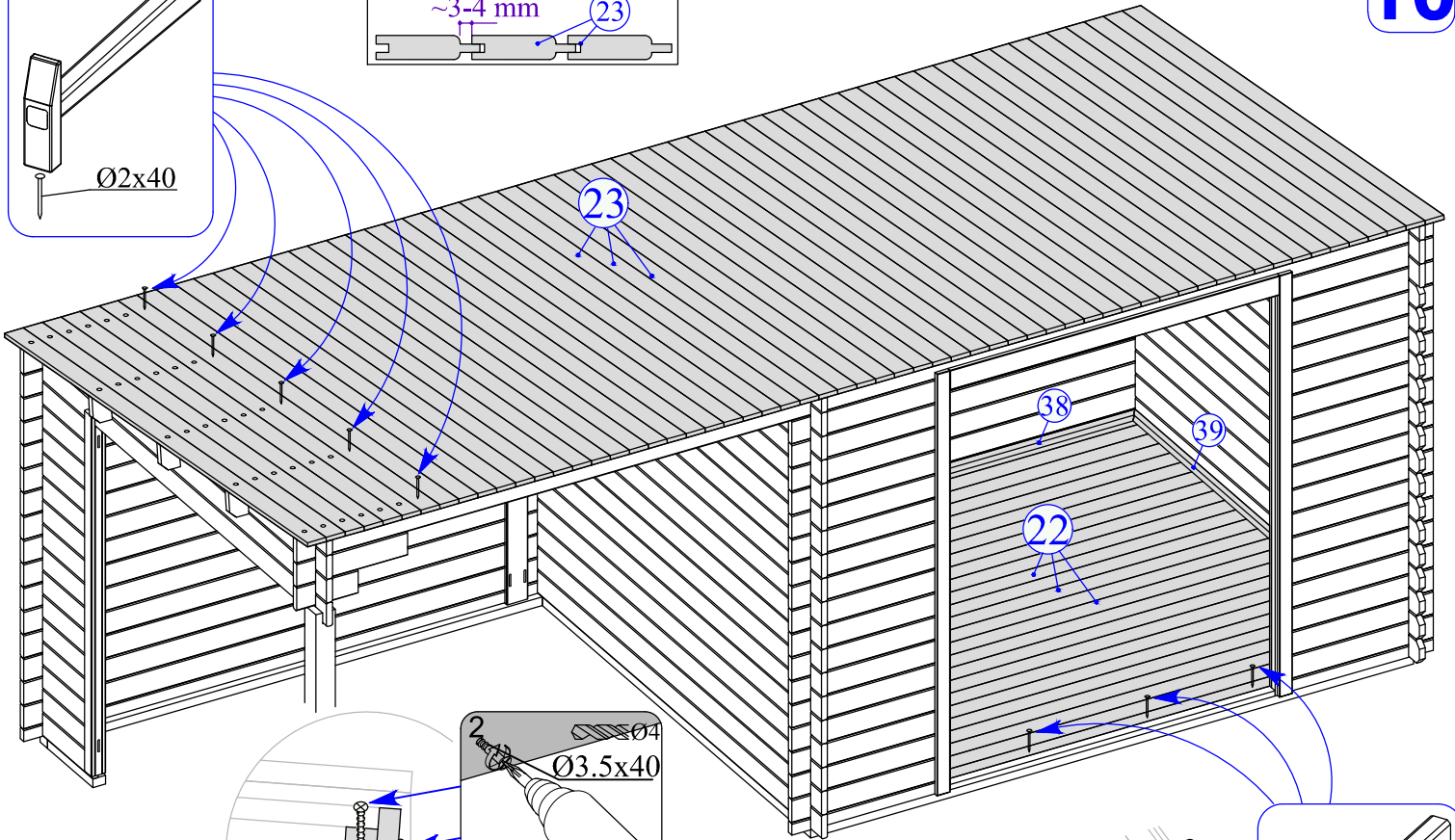
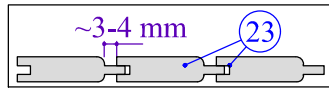
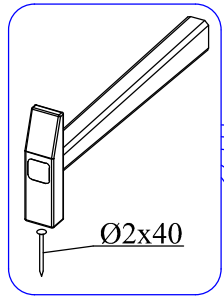

11

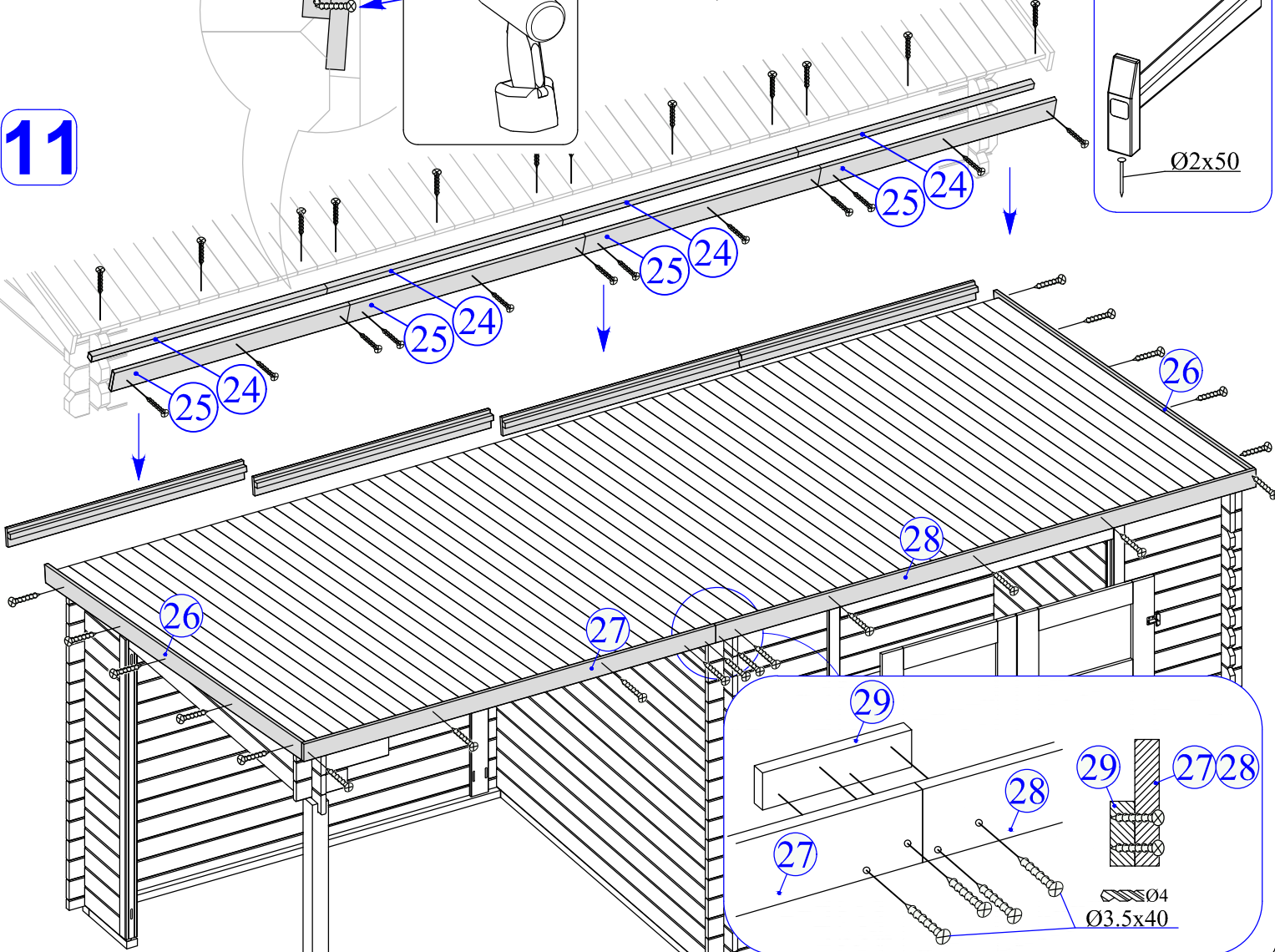
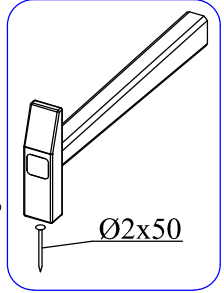
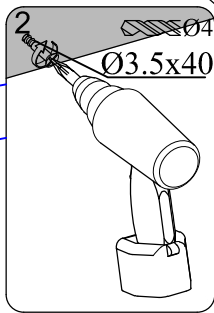

12

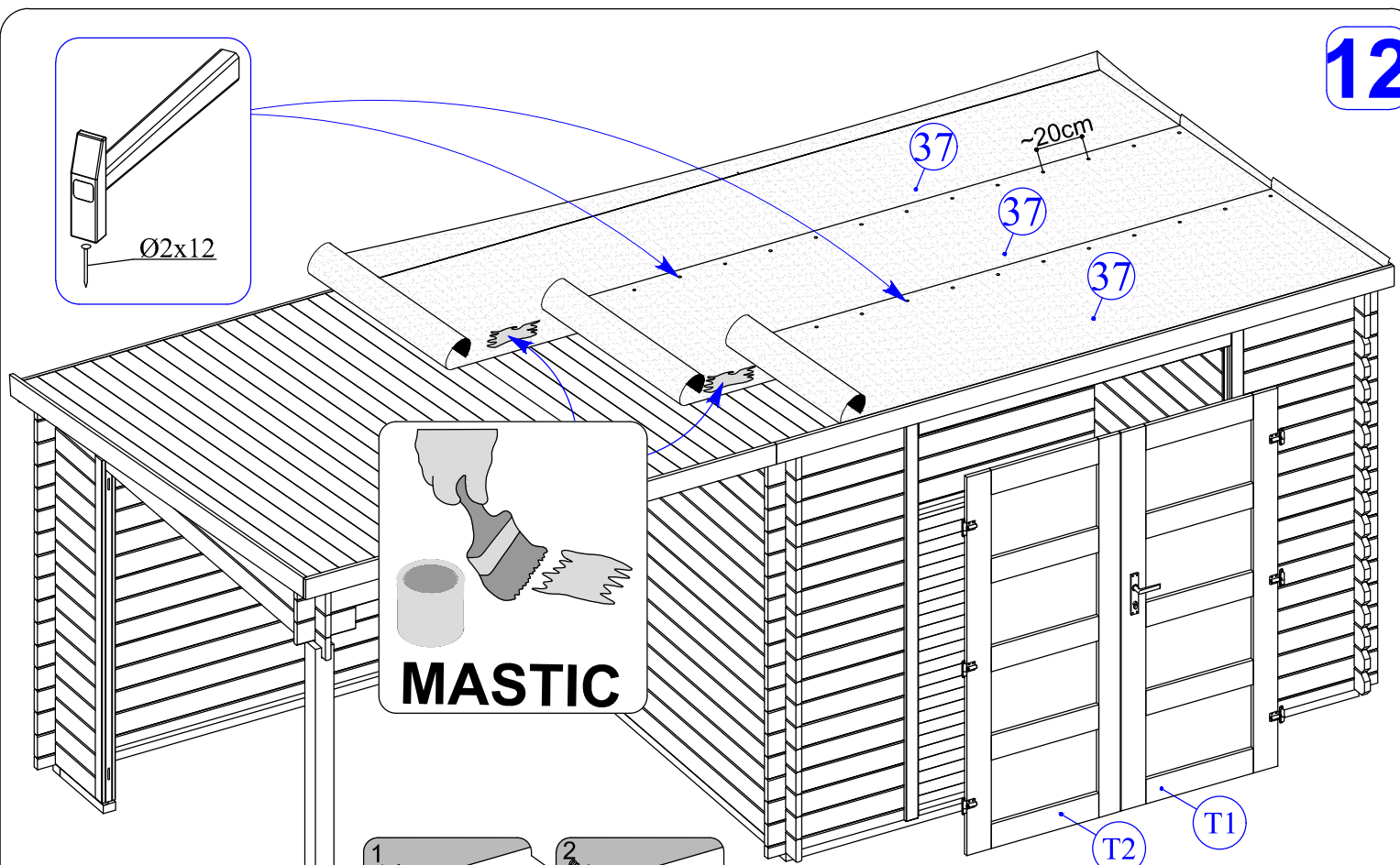
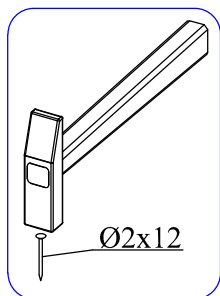

13

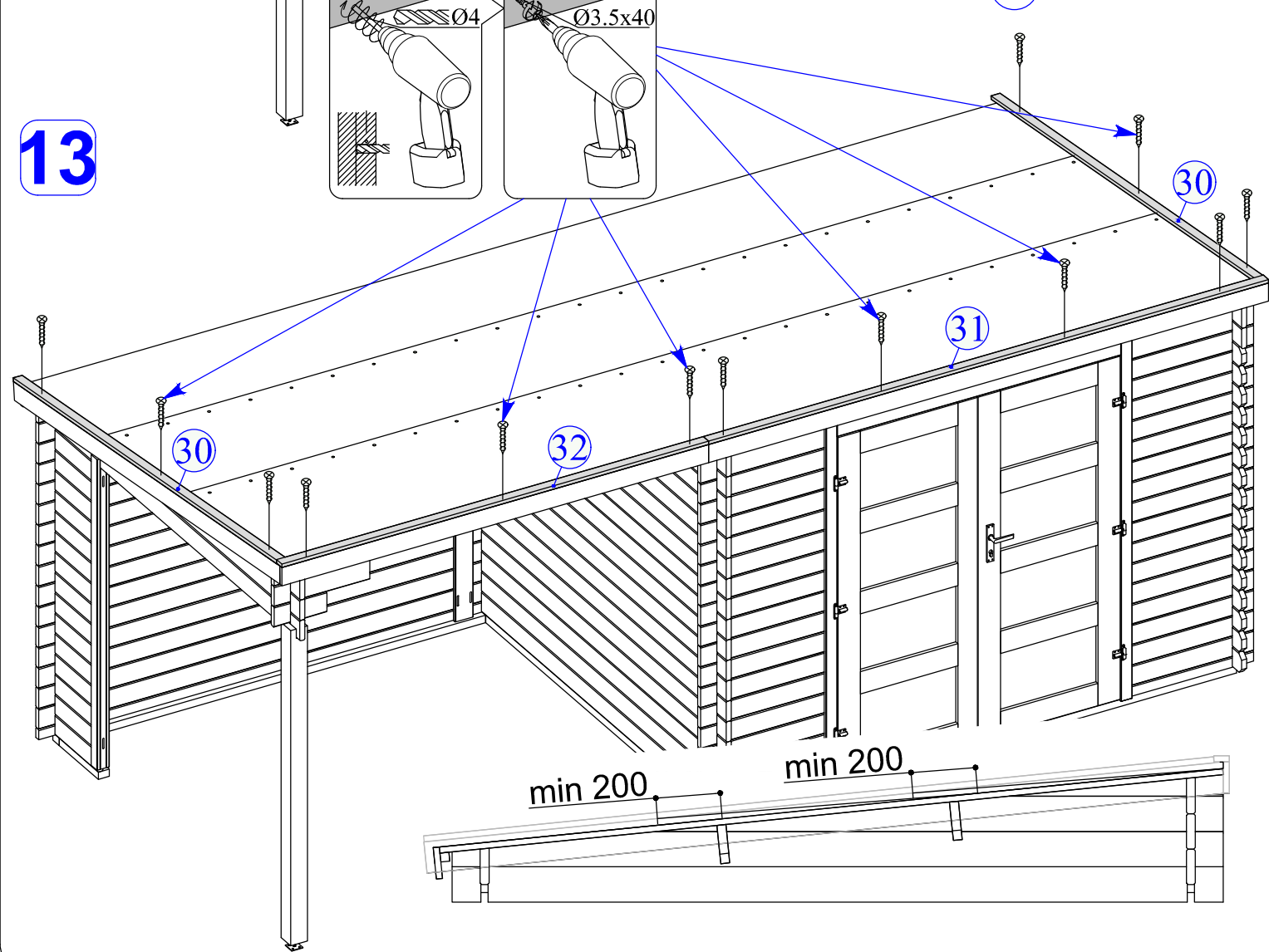
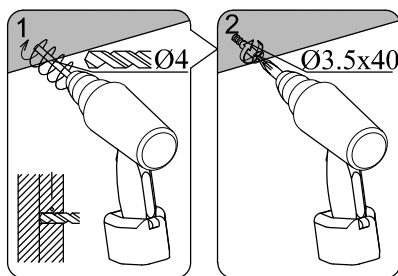

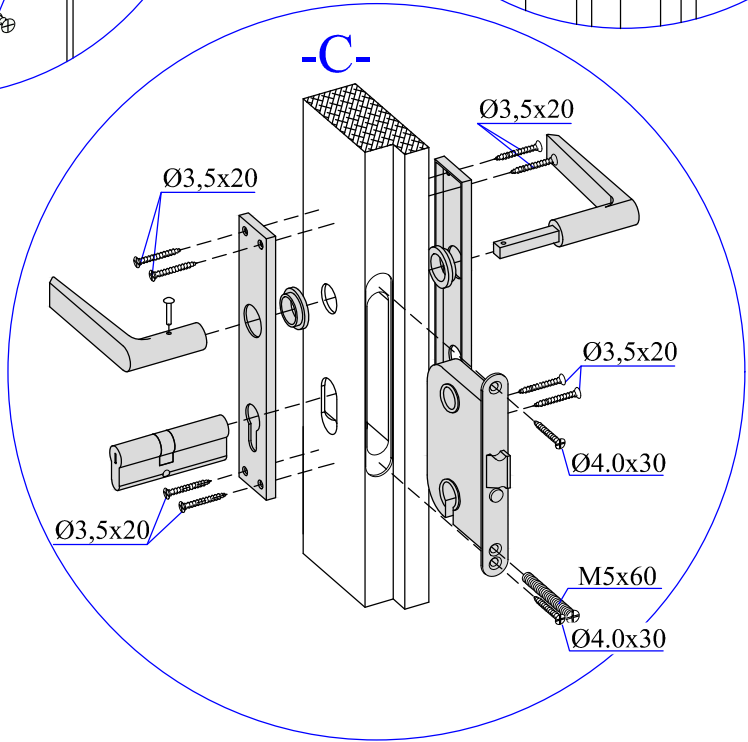
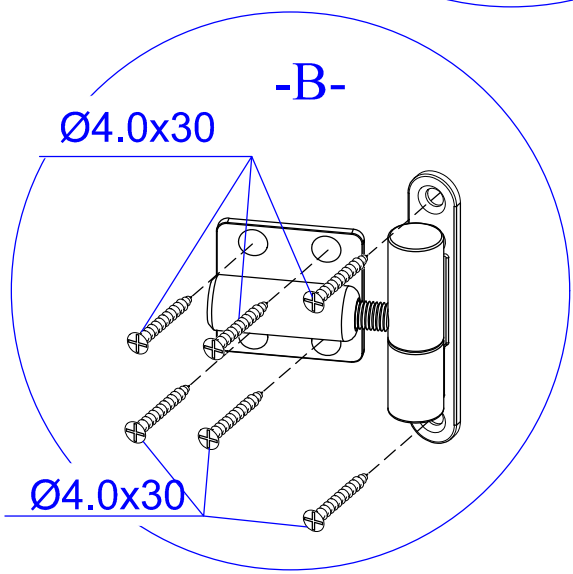
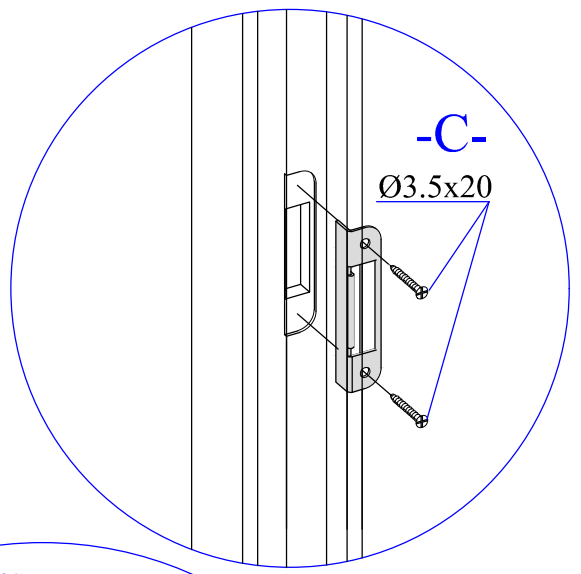
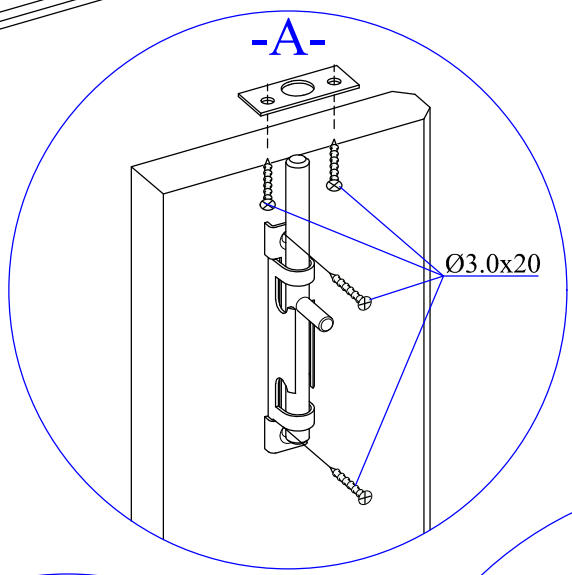
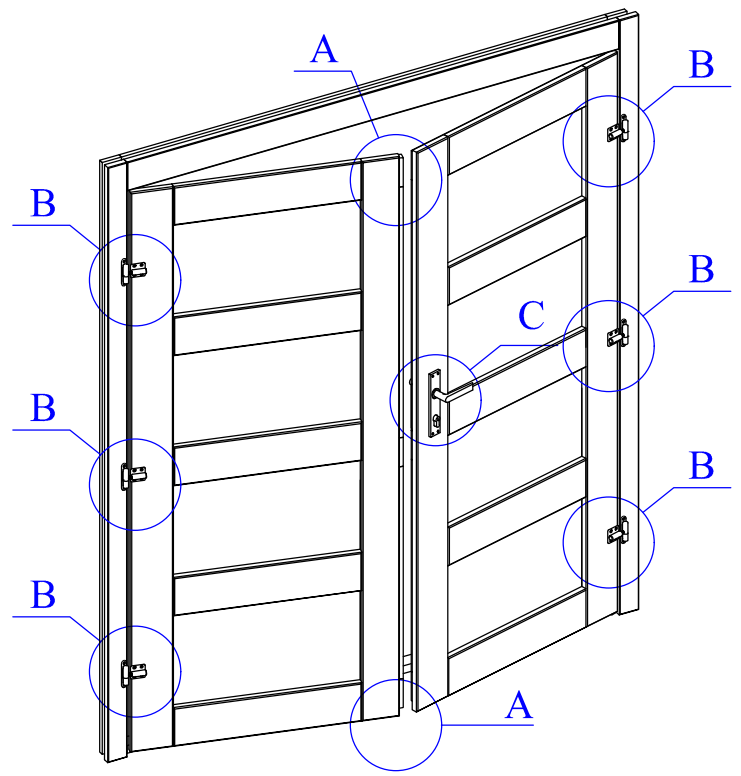
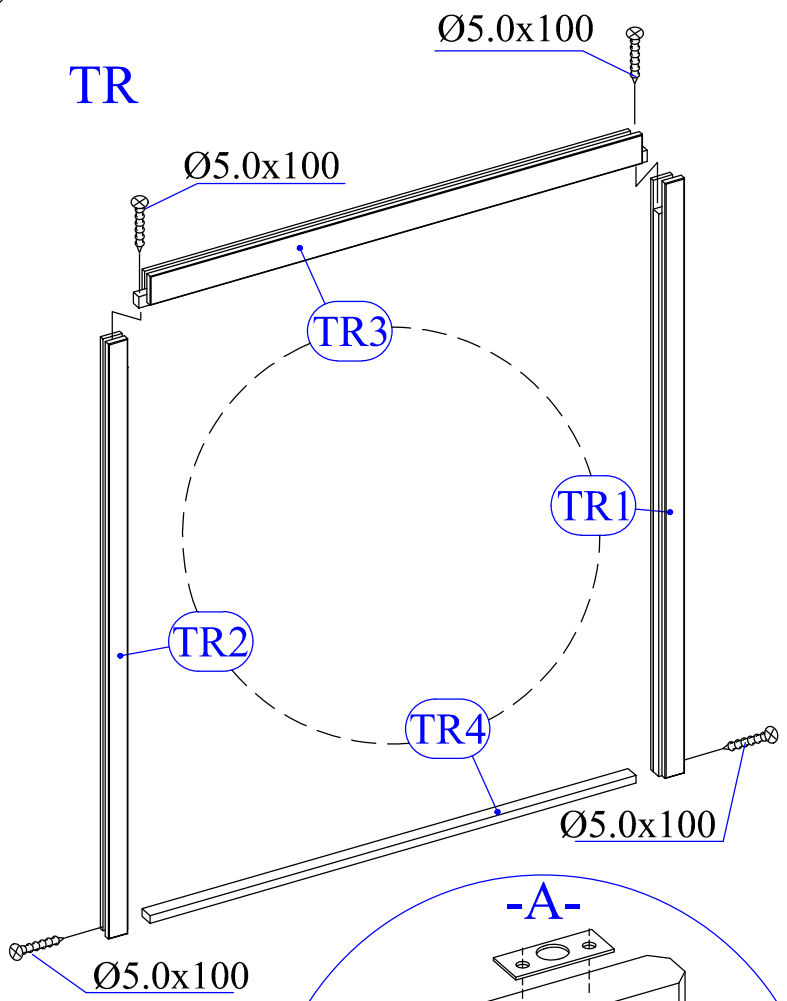

-B-

-1-

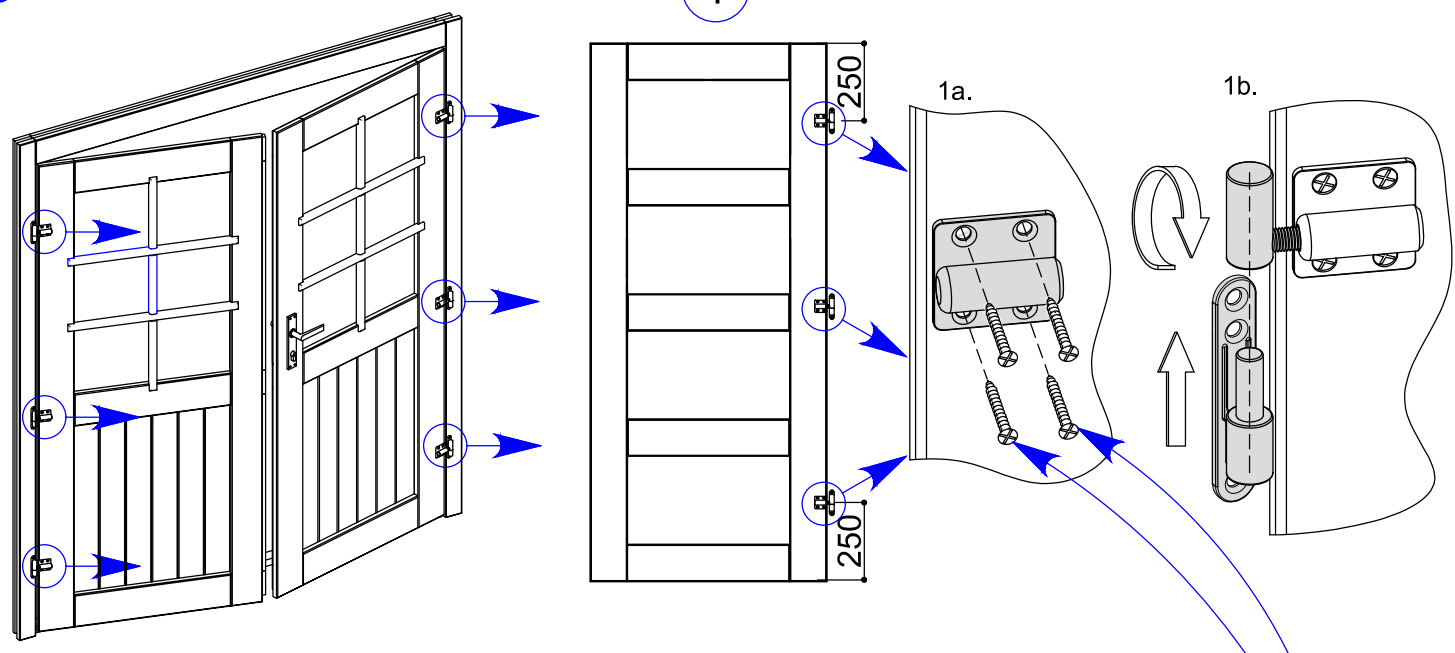

-2-

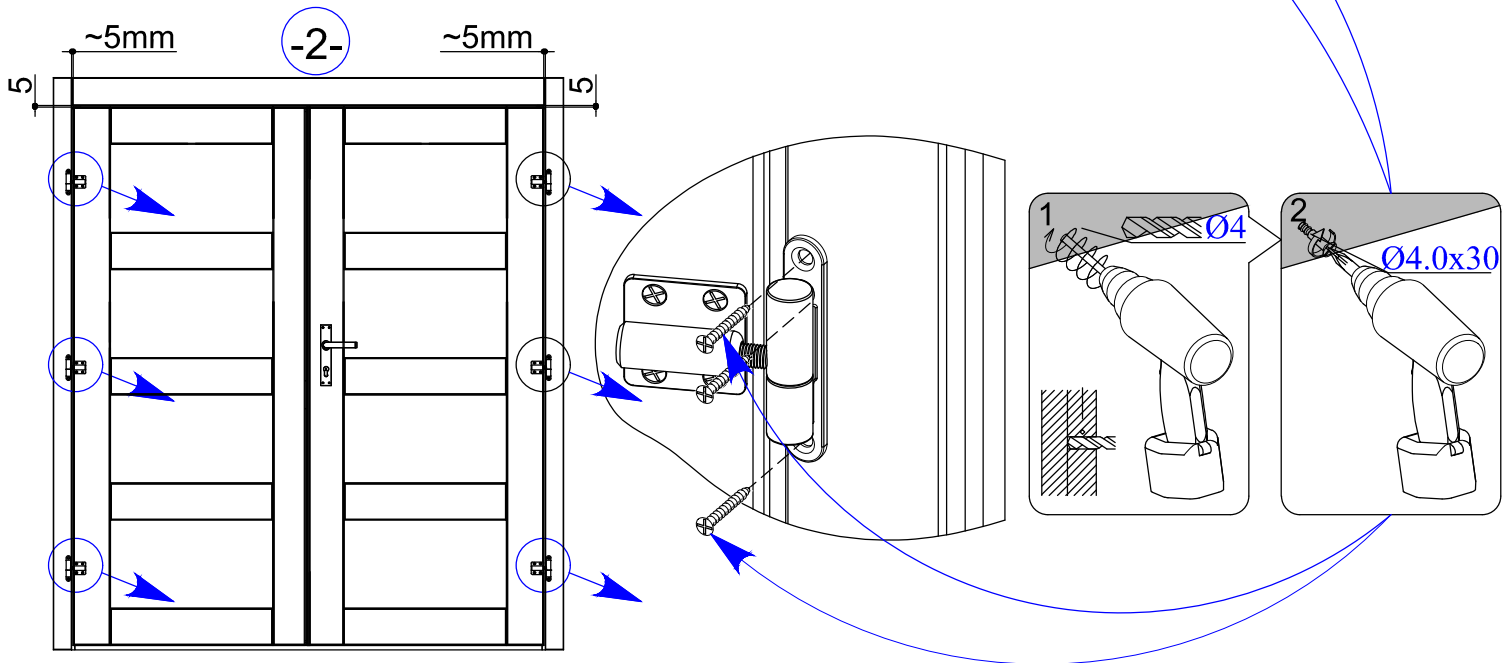

-3-

