

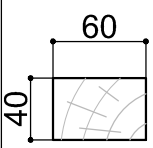

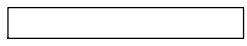

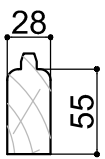

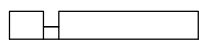

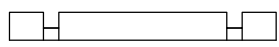
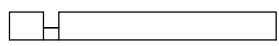
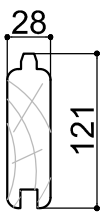

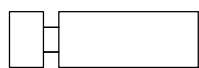

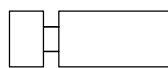
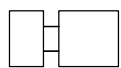
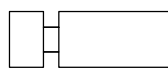
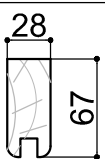

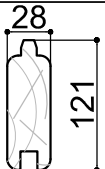
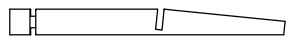
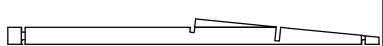
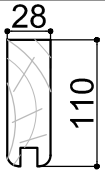
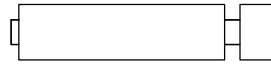

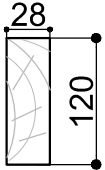
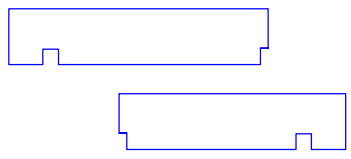
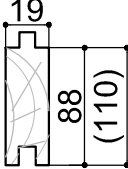
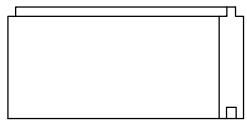
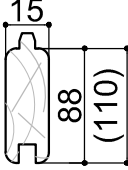
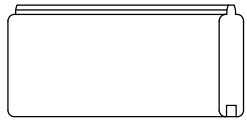
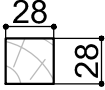
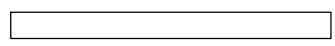
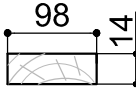

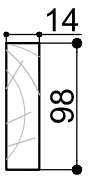
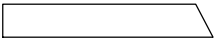
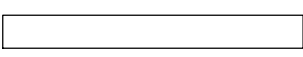

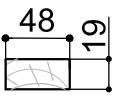

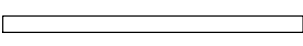
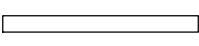
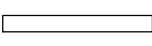
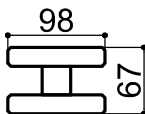
Maße, Dim., Dim.	Skizze, dessin, sketch	Pos.	Länge, longueur, Length	Menge, quantité, quantity	Name, nom, name.
		①	2800	2	Fundamentbalken Lambourdes Foundation beam
		②	2100	6	
		③	2300	1	
		④	365	1	
		⑤	692	2	Brett für Vorderseite, Madrier avant, Front board
		⑥	2980	1	Brett für Rückseite, Madrier arrière, Back board
		⑫	2265	1	Brett für Rückseite, Madrier arrière, Back board
		⑦	2400	33	Brett für Seitenwand, Madrier latéral, Side board
		⑧	2980	15	Brett für Rückseite, Madrier arrière, Back board
		⑨	692	34	Brett für Vorderseite, Madrier avant, Front board
		⑩	2265	15	Brett für Rückseite, Madrier arrière, Back board
		⑪	515	15	Brett für Seitenwand, Madrier latéral, Side board
		⑬	285	1	Brett für Vorderseite, Madrier avant, Front board
		⑭	515	1	Brett für Vorderseite, Madrier avant, Front board
		⑰	637	3	Brett für Seitenwand, Madrier latéral, Side board
		⑯	1186	3	Brett für Seitenwand, Madrier latéral, Side board
		⑮	2400	3	Brett für Seitenwand, Madrier latéral, Side board
		⑱	2880	2	Brett für Vorderseite / Rückseite, Madrier avant / Madrier arrière, Front board / Back board
		⑲	2400	2	

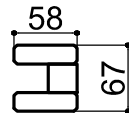
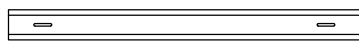
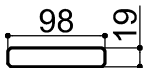
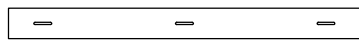
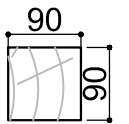
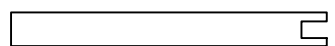
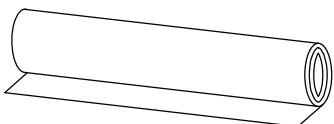
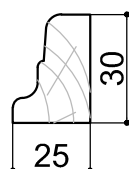
Maße, Dim., Dim.	Skizze, dessin, sketch	Pos.	Länge, longueur, Length	Menge, quantité, quantity	Name, nom, name.
		20	2880	3	Sparren, Panne faîtière,
		21	2400	3	Rafter
		22	2740	25 (20)	Bodenbrett Plancher bois Floor board
		23	2450	60 (48)	Dachbrett, Madrier de toit, Roof board
		24	1760	3	Dachlatte, Latte de toit, Roof lath
		25	1760	3	Dachlatte, Latte de toit, Roof lath
		26	2500	2	Windbrett, Planche de rive, Wind board
		27	2300	1	Windbrett, Planche de rive, Wind board
		28	3018	1	Windbrett, Planche de rive, Wind board
		29	250	1	Windbrett, Planche de rive, Wind board
		30	2470	2	Dachlatte, Latte de toit, Roof lath
		31	3018	1	Dachlatte, Latte de toit, Roof lath
		32	2300	1	Dachlatte, Latte de toit, Roof lath

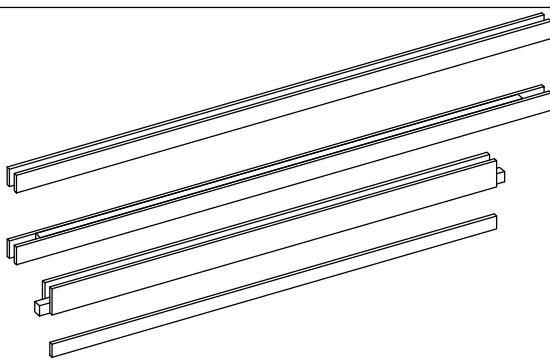
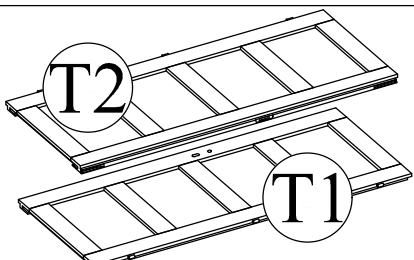
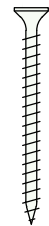
Maße, Dim., Dim.	Skizze, dessin, sketch	Pos.	Länge, longueur, Length	Menge, quantité, quantity	Name, nom, name.
		33	1780	1	Verbindungsleiste, Pièce de connexion, Connecting part
		34	1670	1	Verbindungsleiste, Pièce de connexion, Connecting part
		35	1780	1	Verbindungsleiste, Pièce de connexion, Connecting part
		36	1700	1	Pfosten, Pôle, Post
		37	5400	3	Dachpappe, Feutre bitumé, Bitume
		38	2750	1	Bodenleiste, Lame de plancher, Skirting board
		39	2170	2	
		40	555	2	
	TR1	1960	1	Türrahmen links, Cadre de porte gauche, Door frame left	
	TR2	1960	1	Türrahmen rechts, Cadre de porte droite Door frame right	
	TR3	1580	1	Türrahmen oben, Montant supérieur, Door frame top	
	TR4	1510	1	Türstufe, Lame de finition bas Door frame bottom	
	T1	1850x 765	1	Tür, Porte, Doors	
	T2	1850x 765	1	Tür, Porte, Doors	

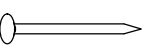
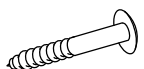
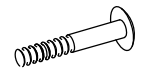
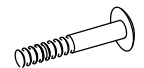
Skizze, dessin, sketch	Maße, Dim., Dim.	Menge, quantité, quantity
	Ø3.5 x 40	71
	Ø5.0 x 100	31
	Ø3.5 x 60	4
	Ø2.0 x 40	300
	Ø2.0 x 50	150
	Ø2.0 x 16	60
	6.3 x 80	2
	M6.0 x 80	6
	M6.0 x 60	3
	Ø6.0	20
	M6	9

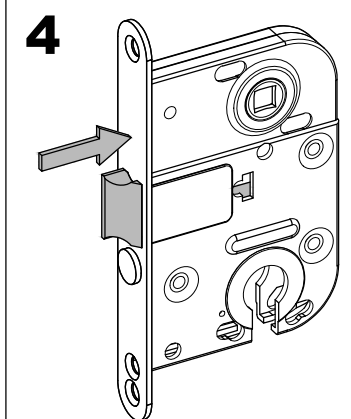
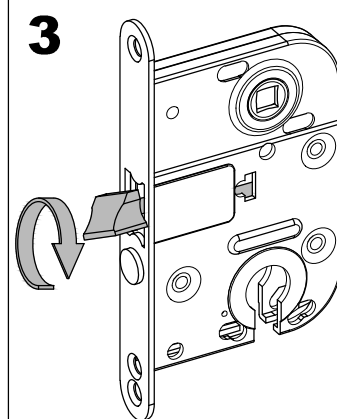
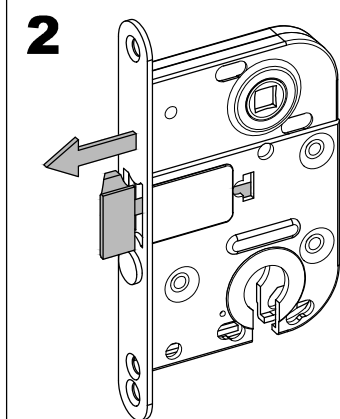
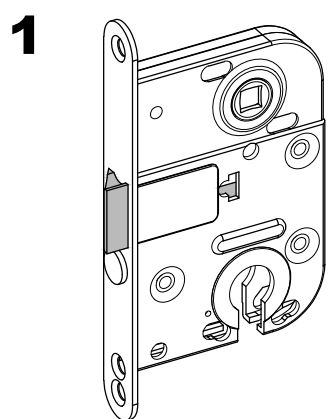
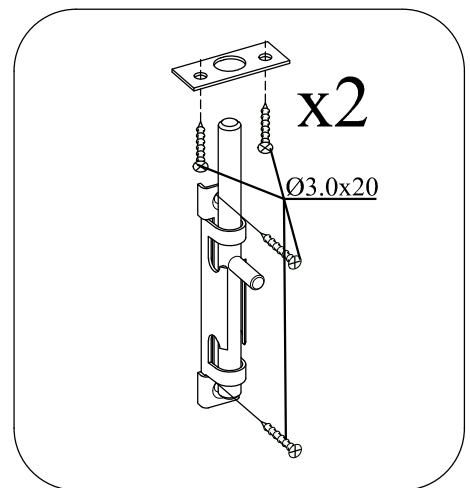
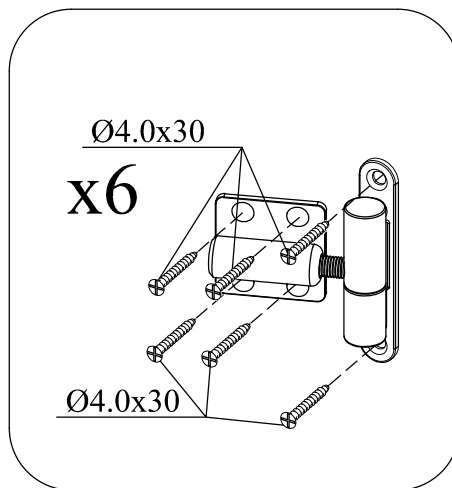
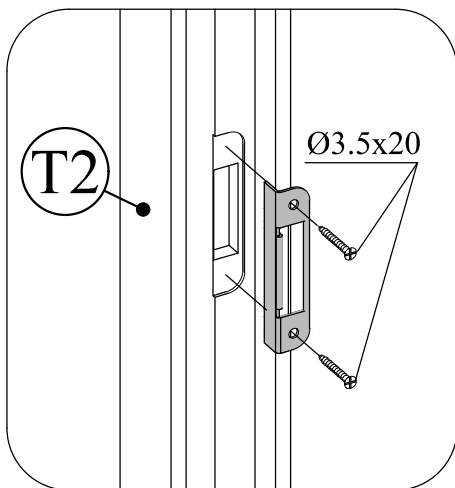
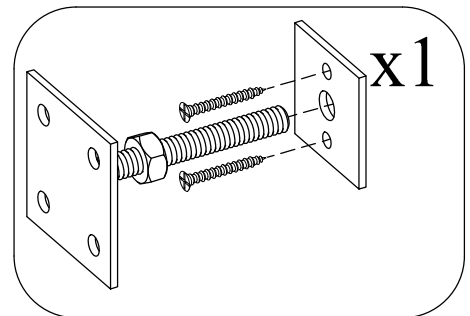
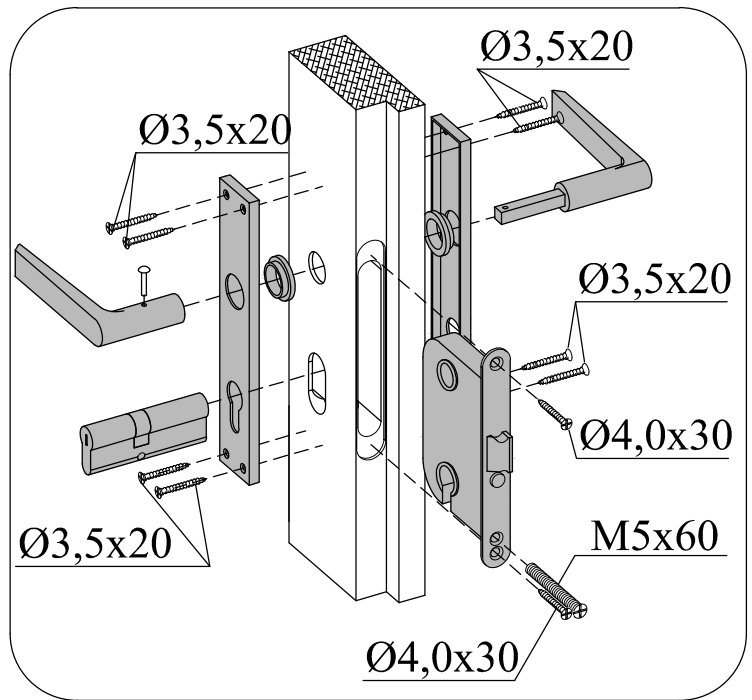



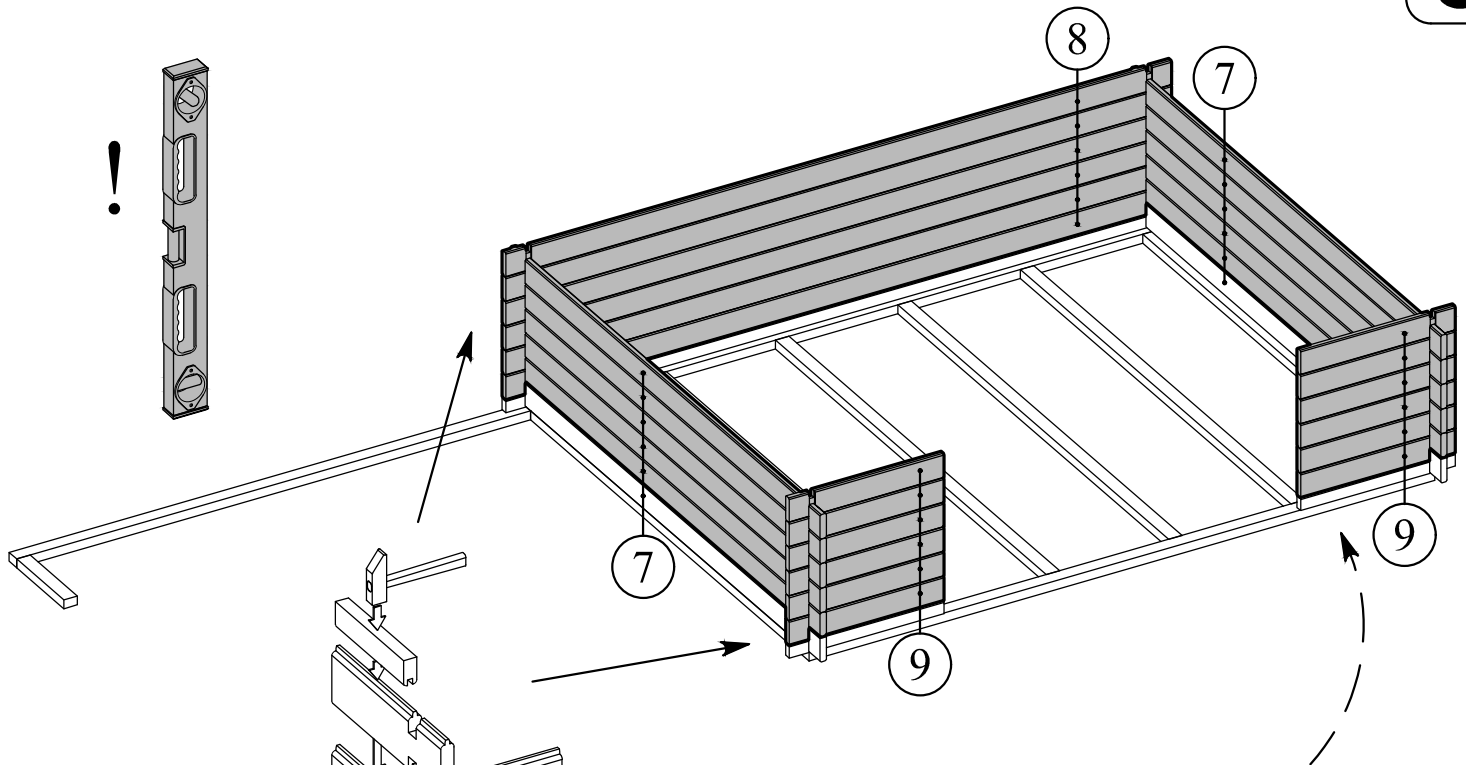

Montage variante  
Assembling variant  
Des option de montage

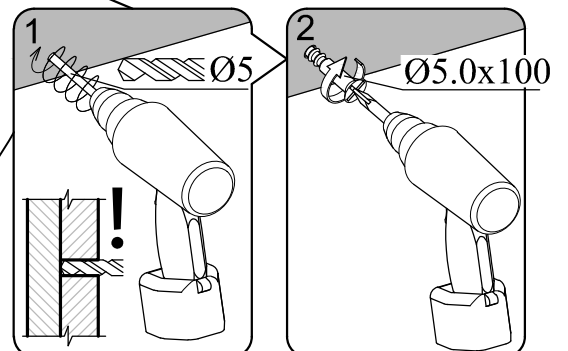
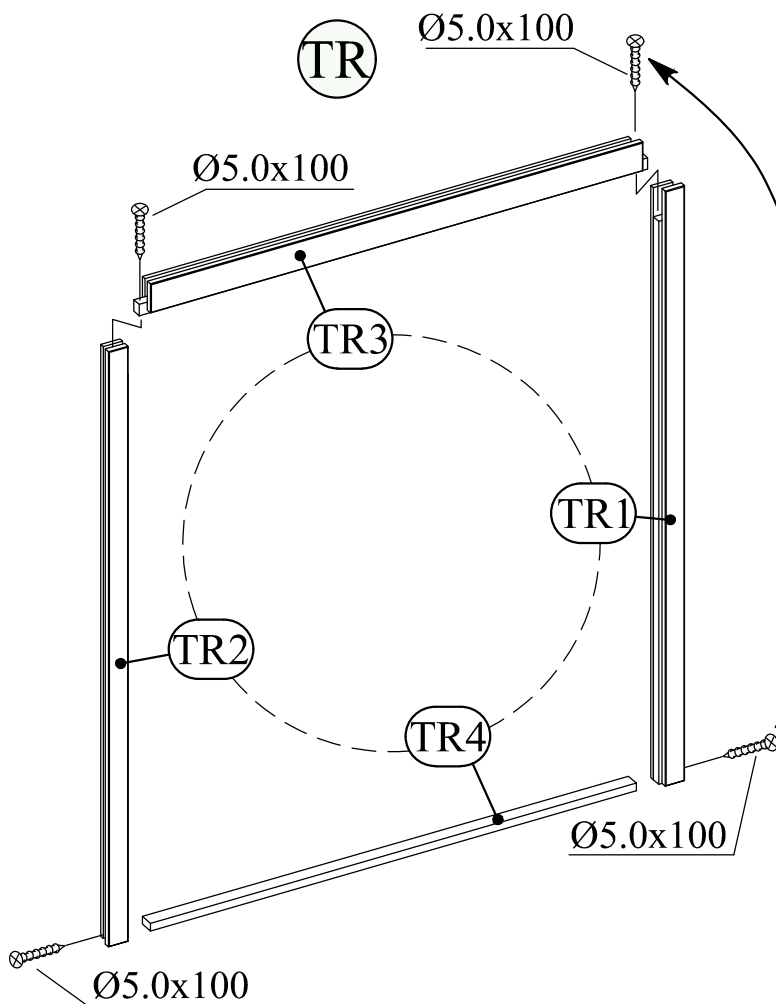
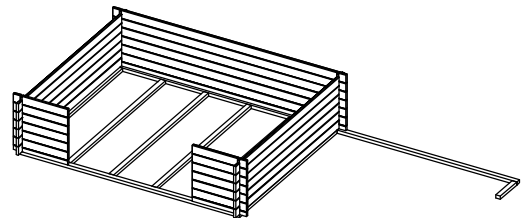

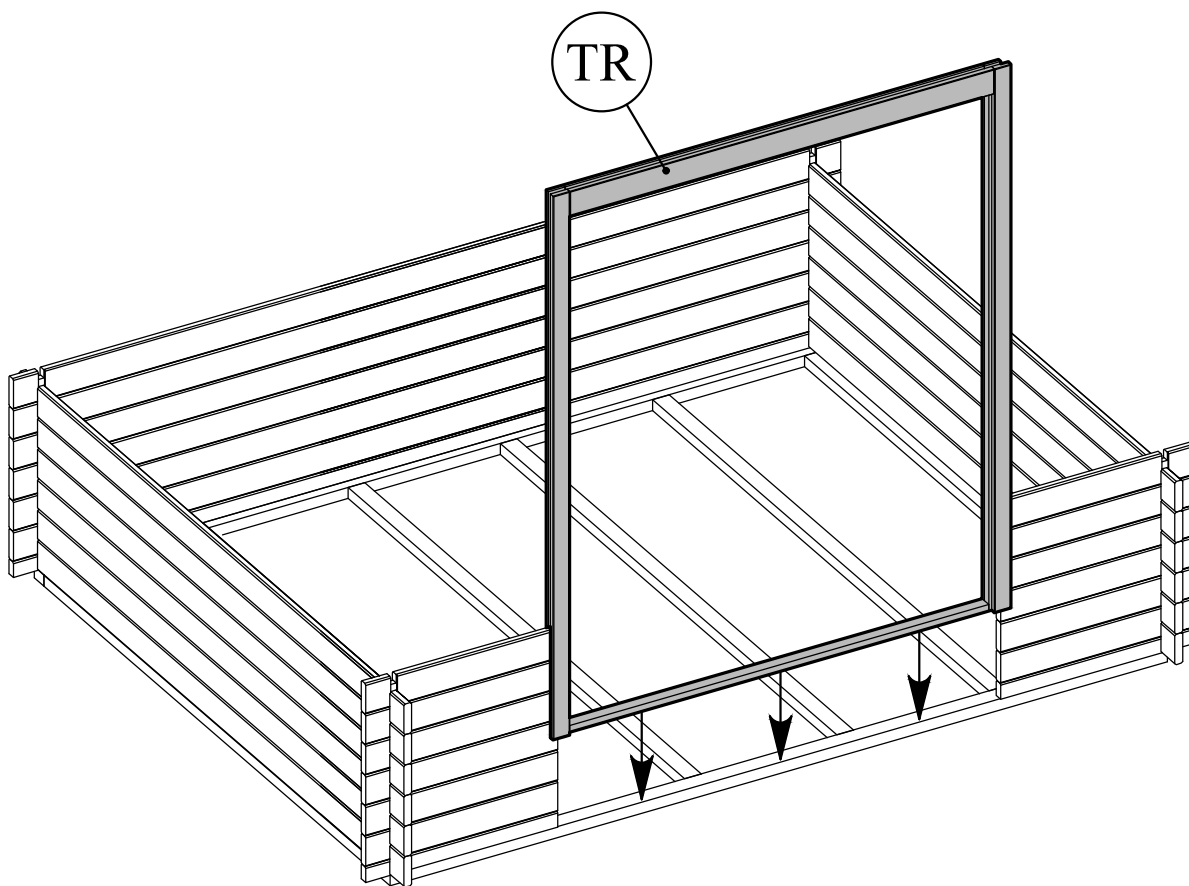
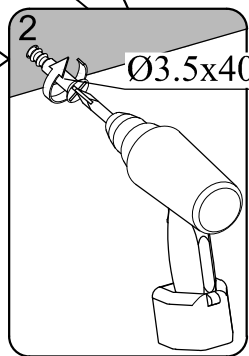
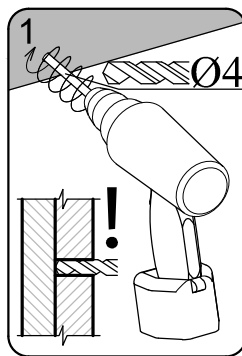
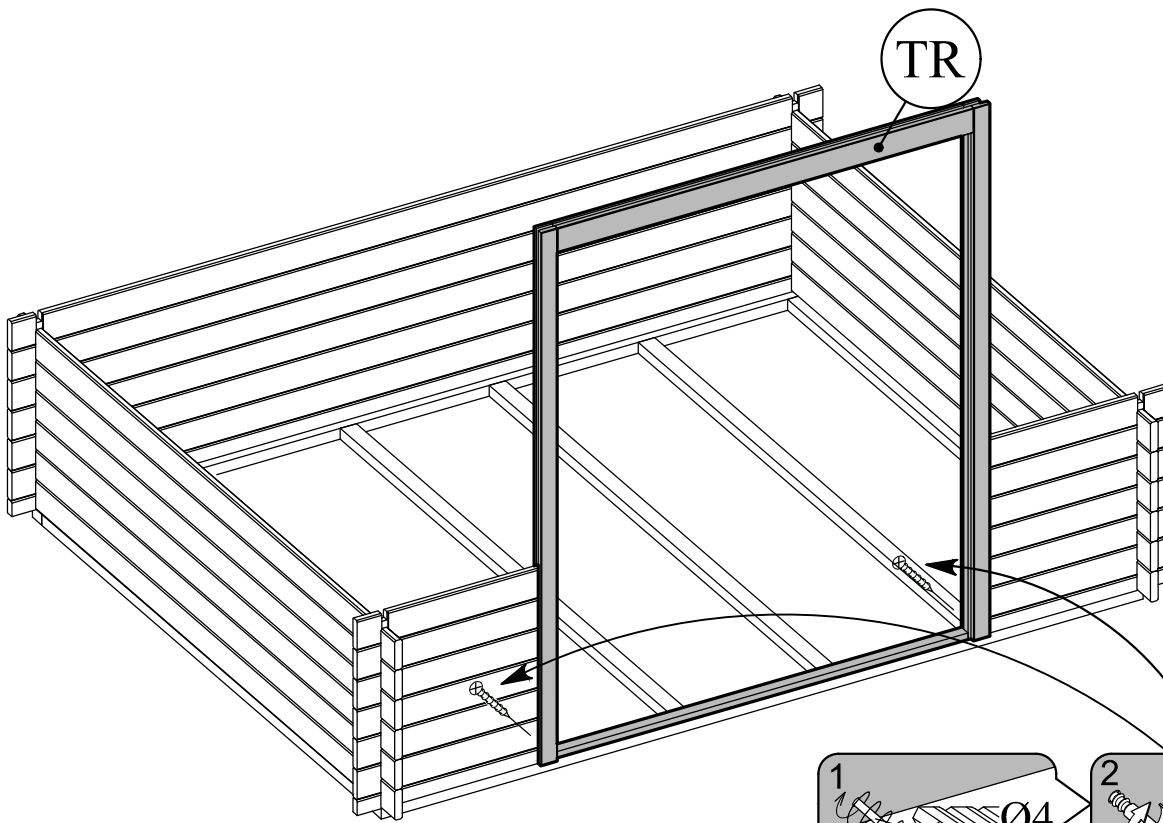

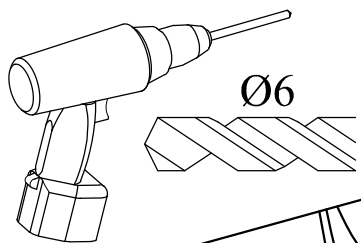

6

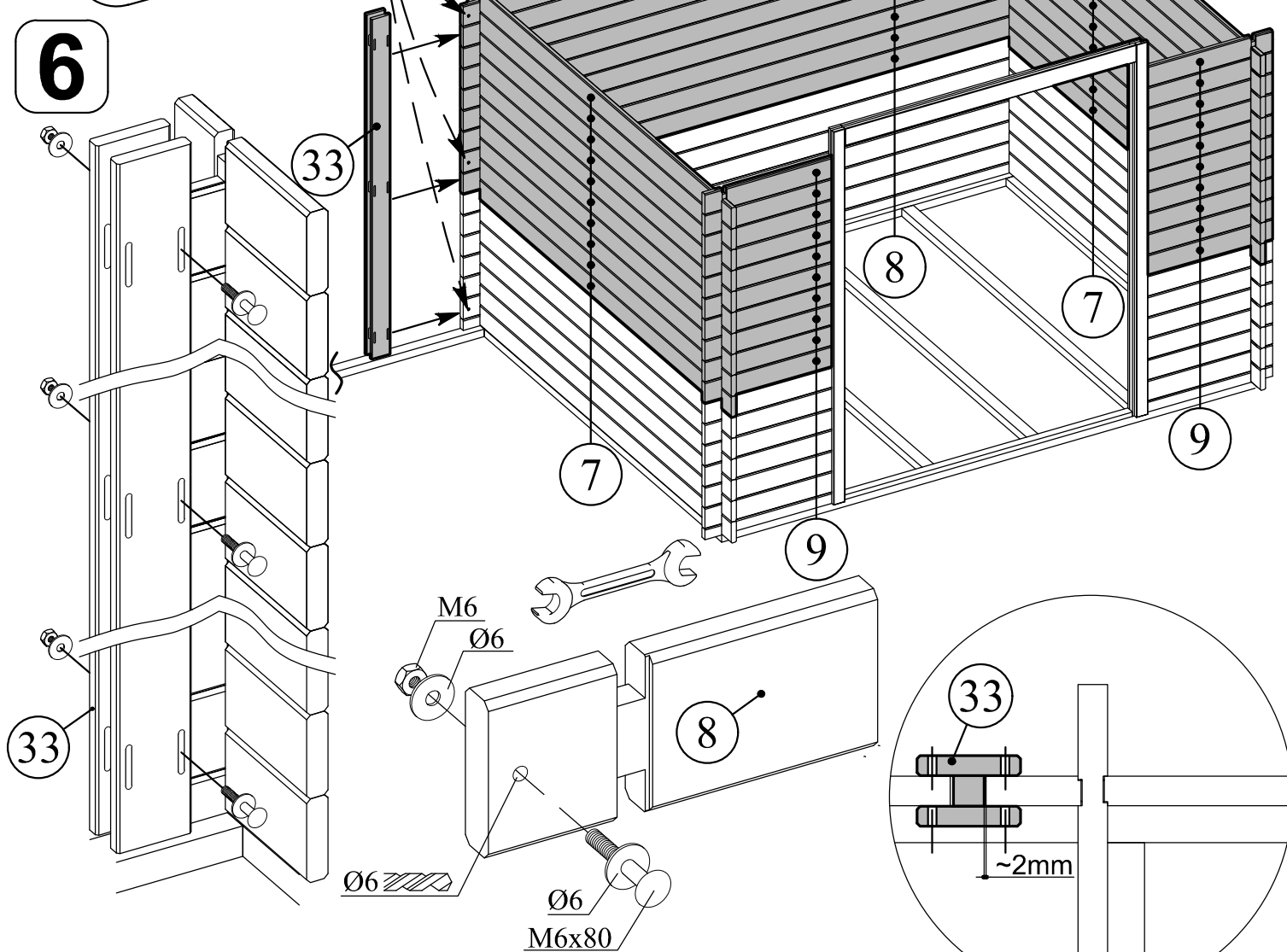

Montage variante  
Assembling variant  
Des option de montage

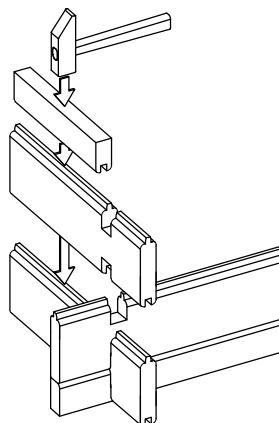
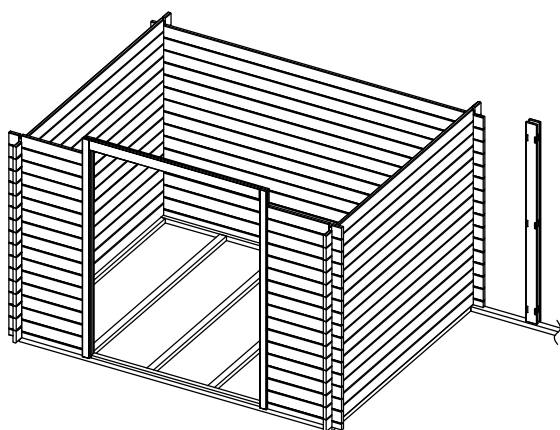

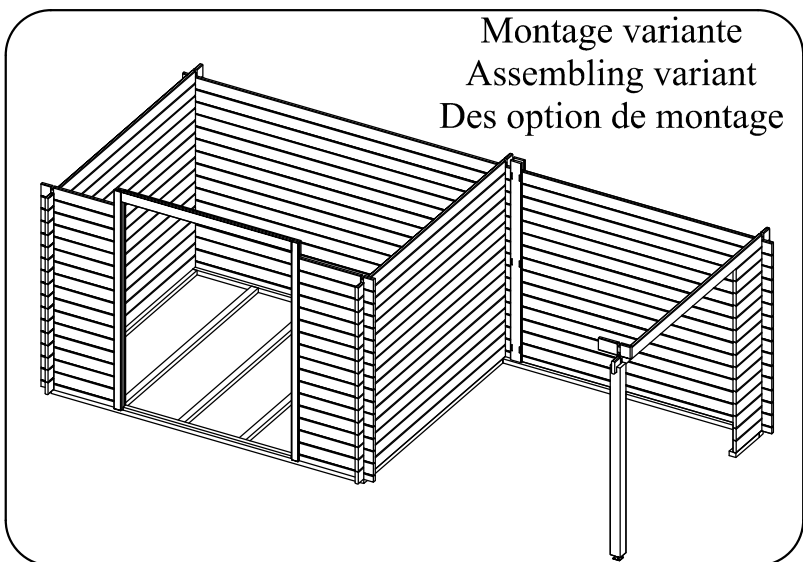
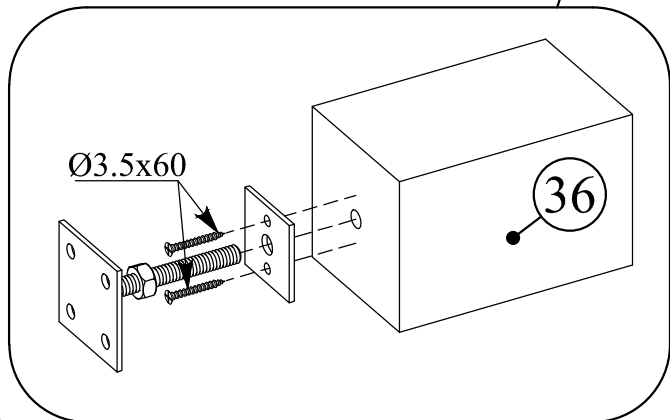
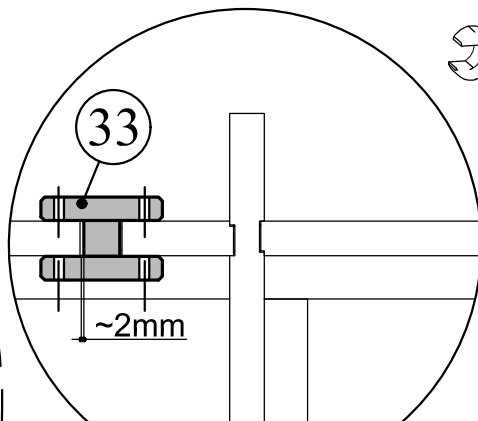
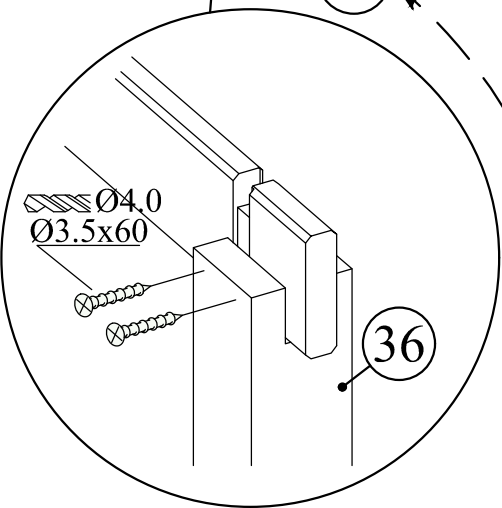
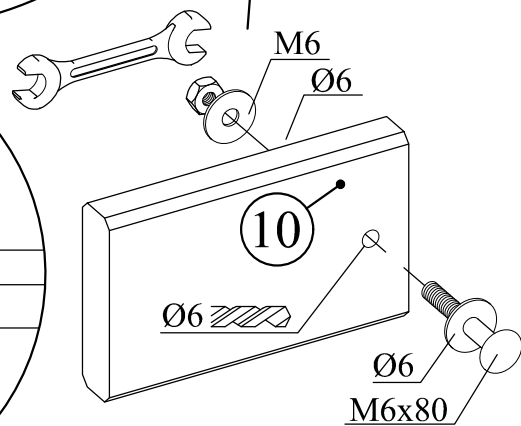
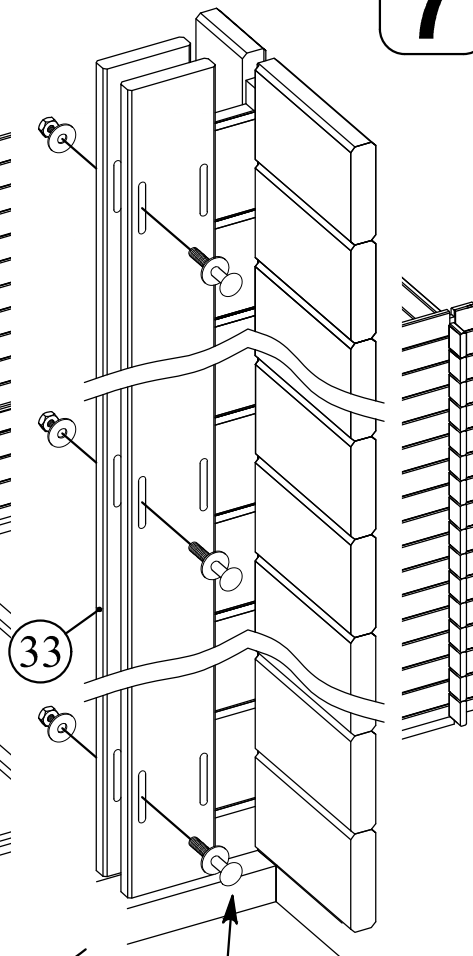
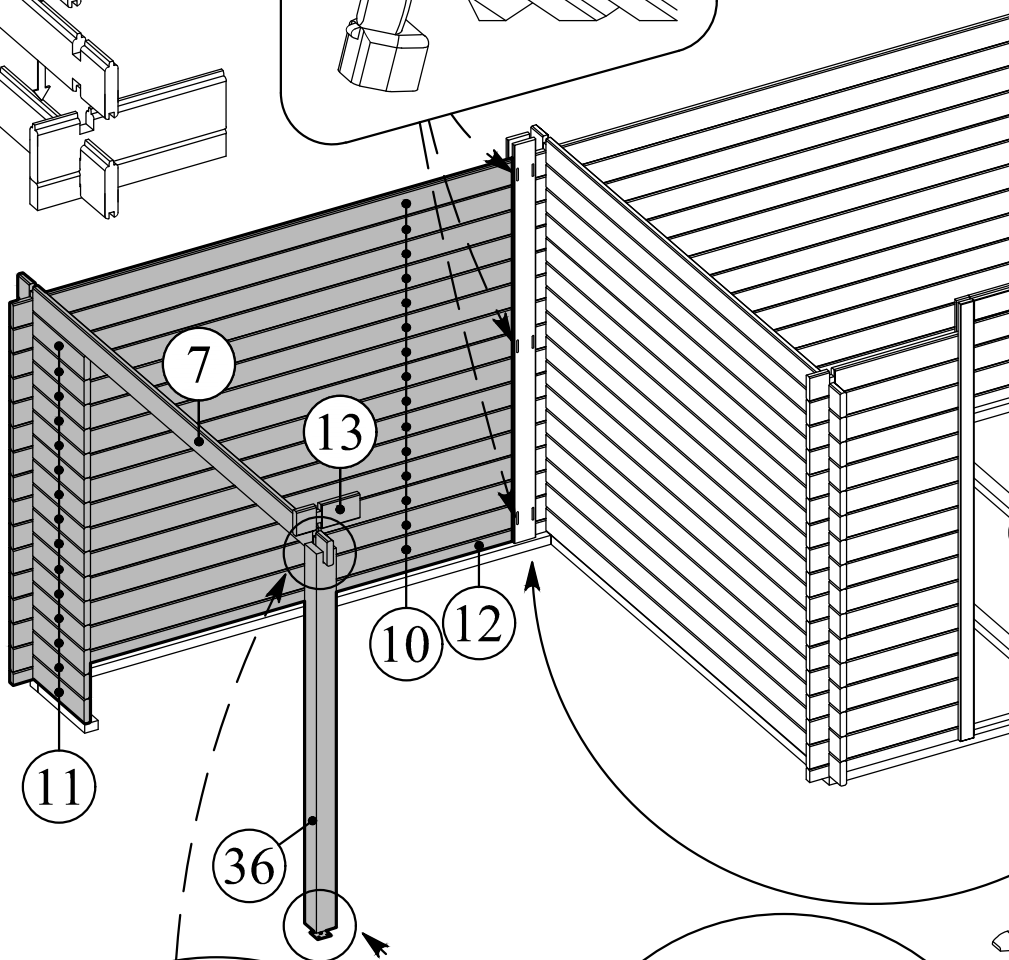
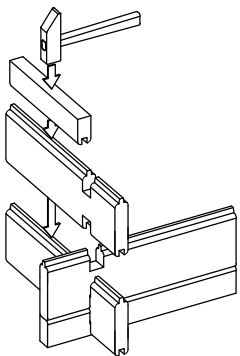
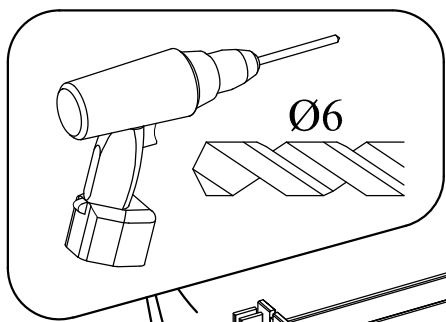

Montage variante  
Assembling variant  
Des option de montage

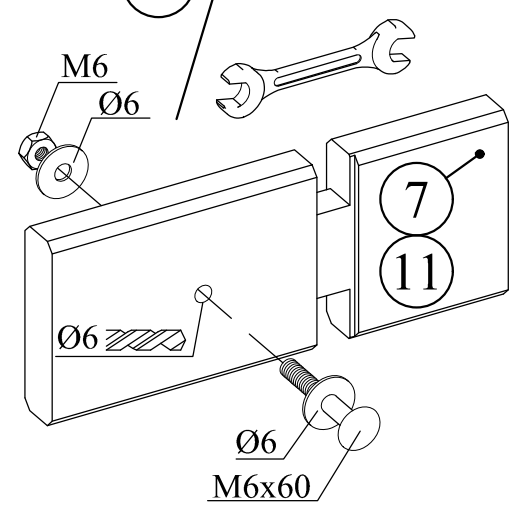
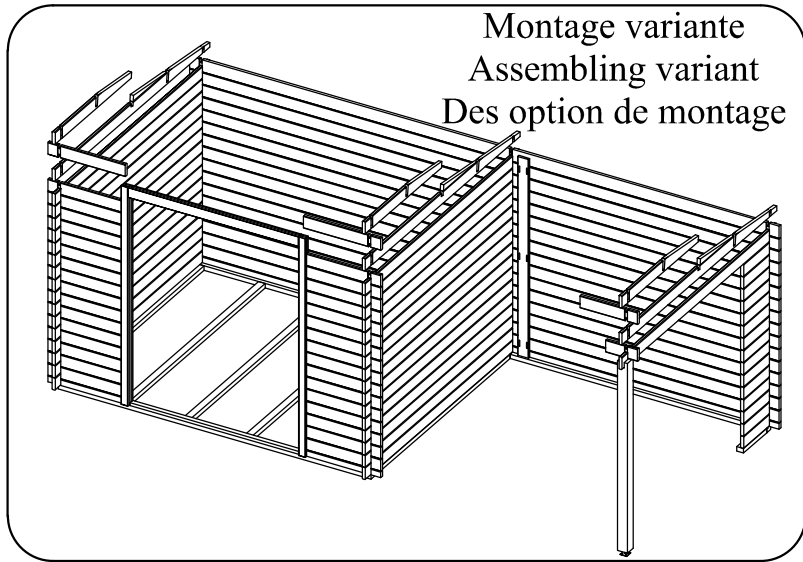
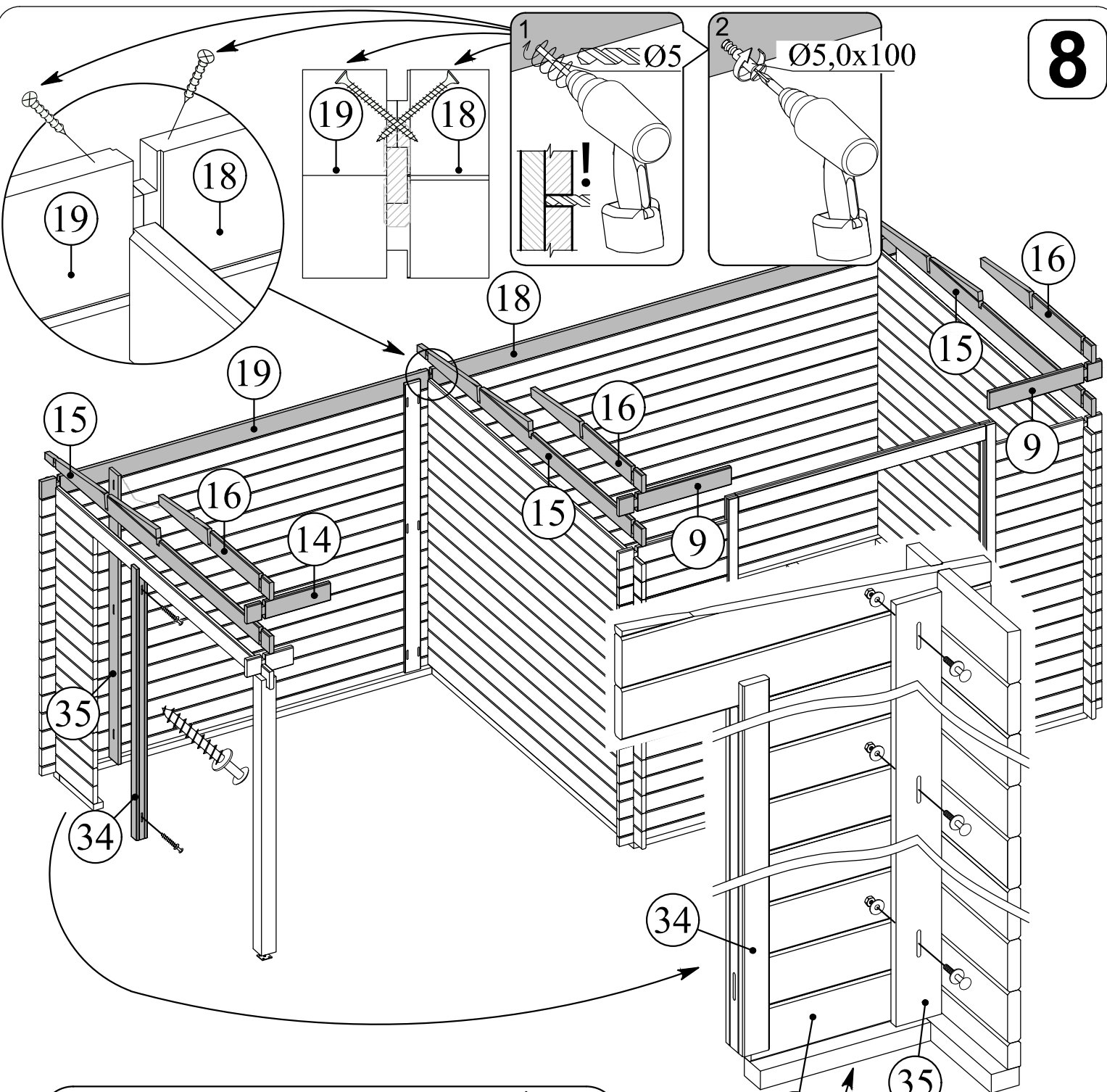

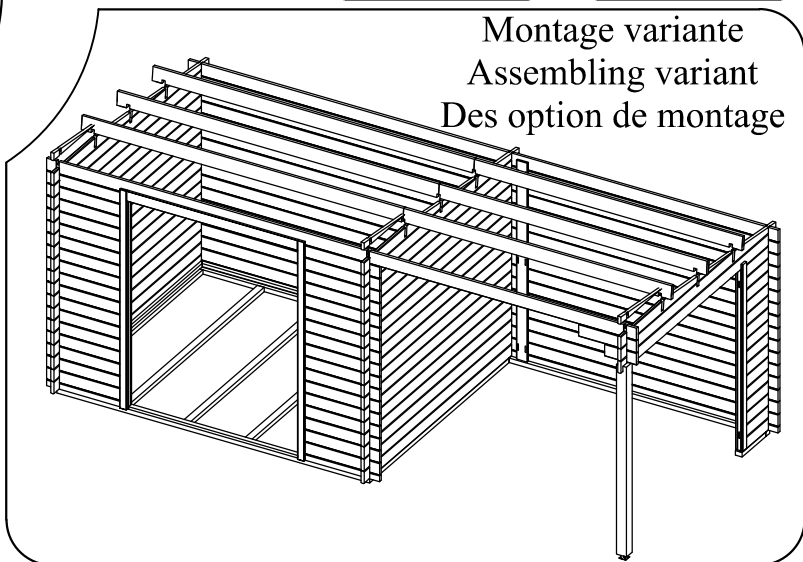
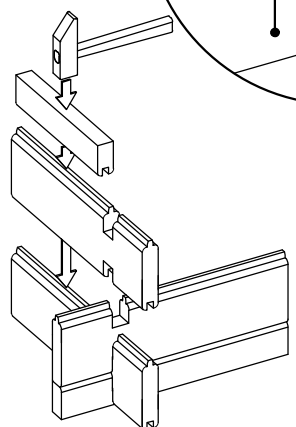
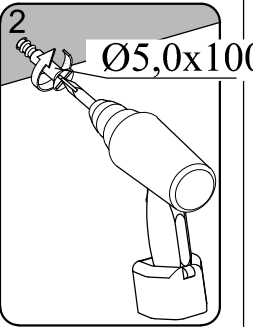
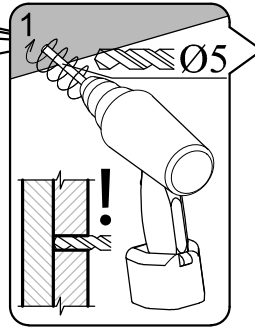
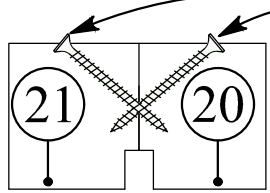
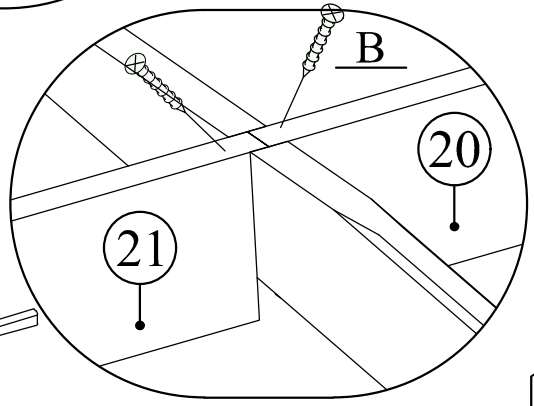
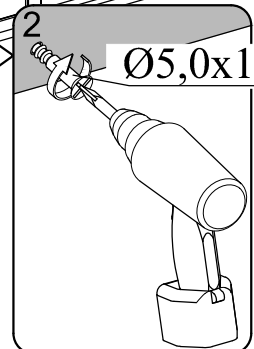
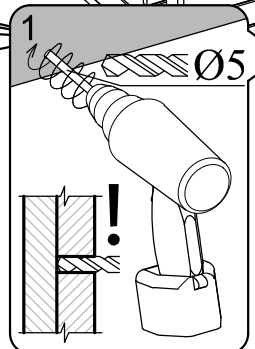
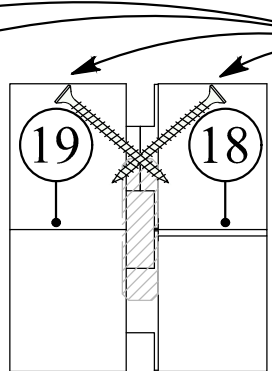
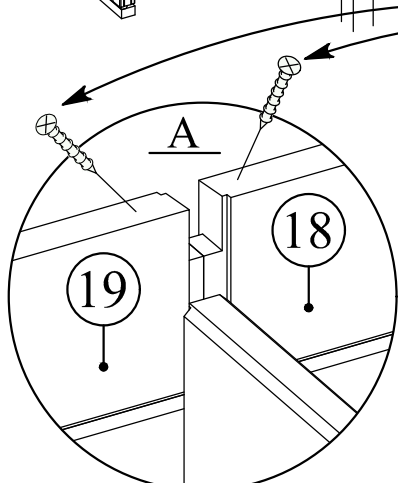
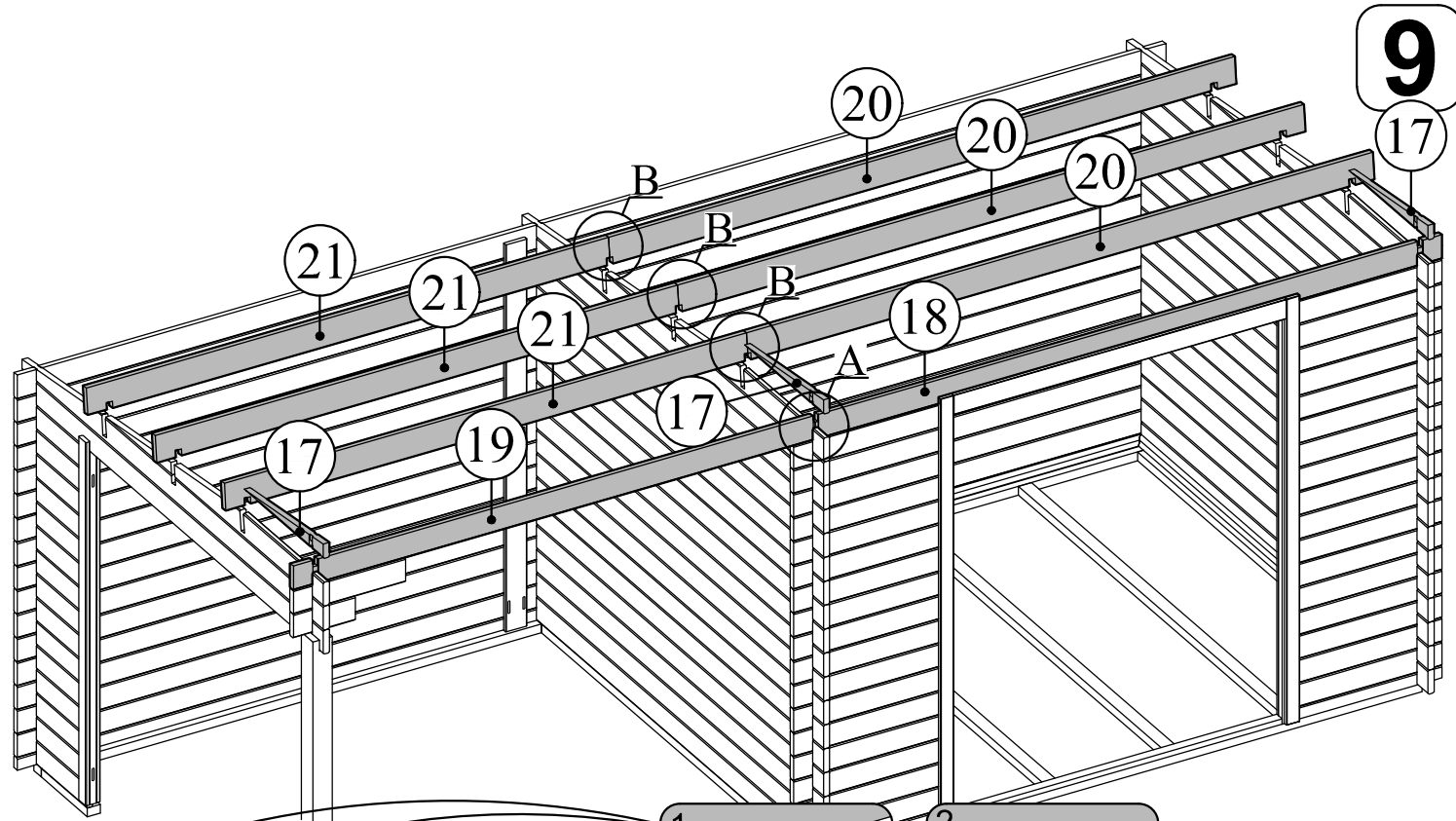

Montage variante  
 Assembling variant  
 Des option de montage

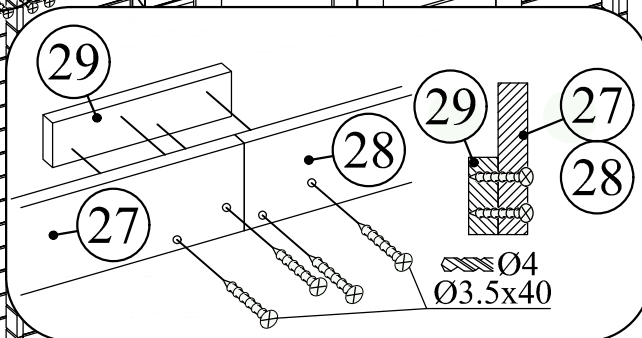
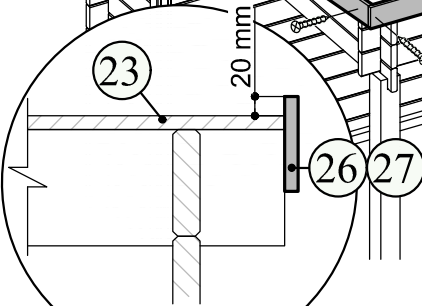
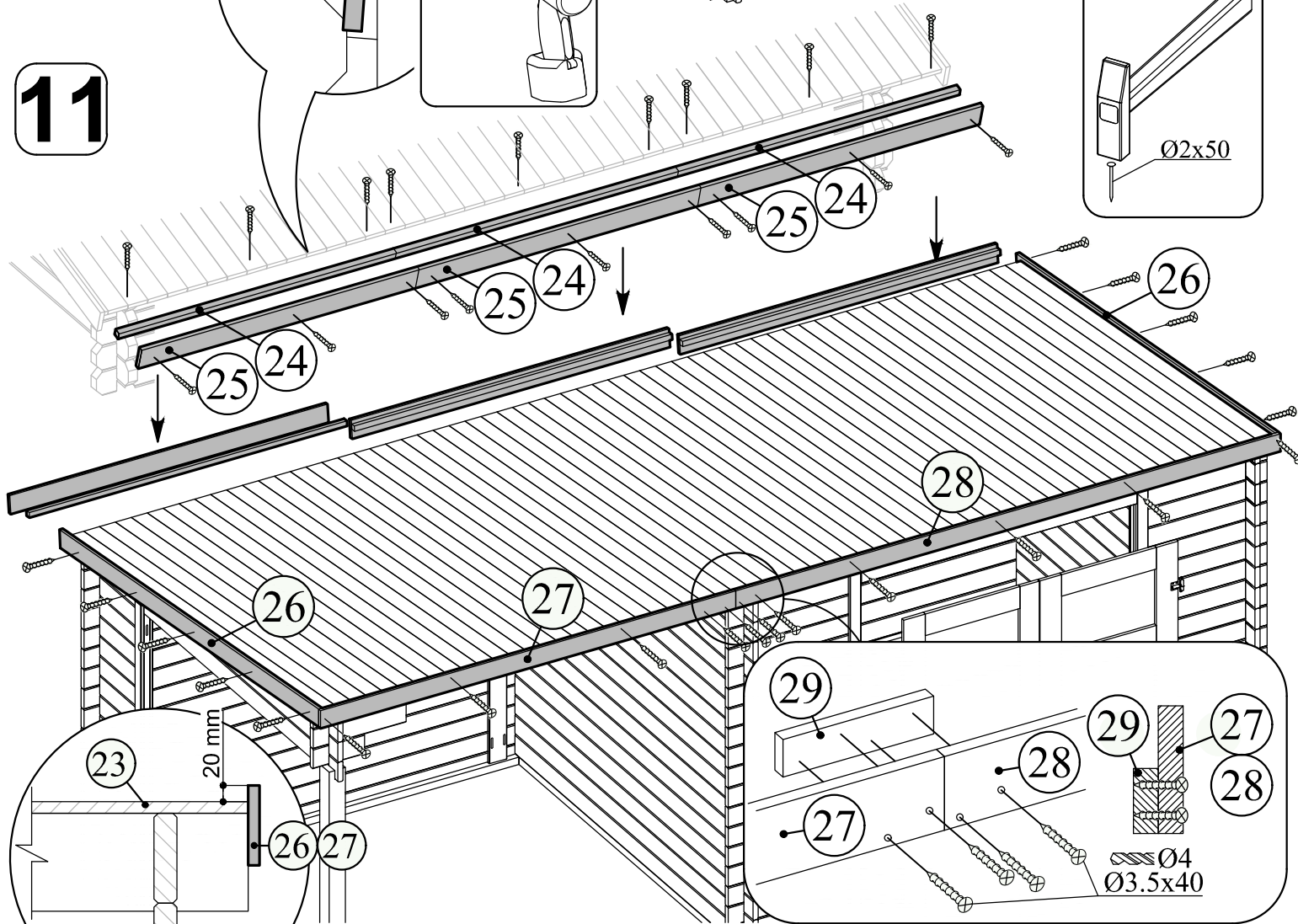
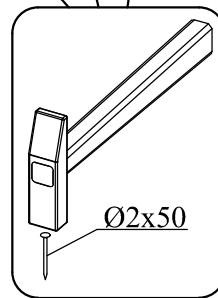
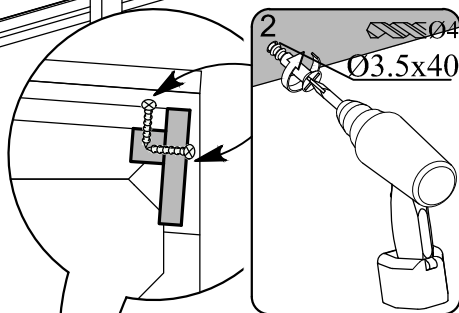
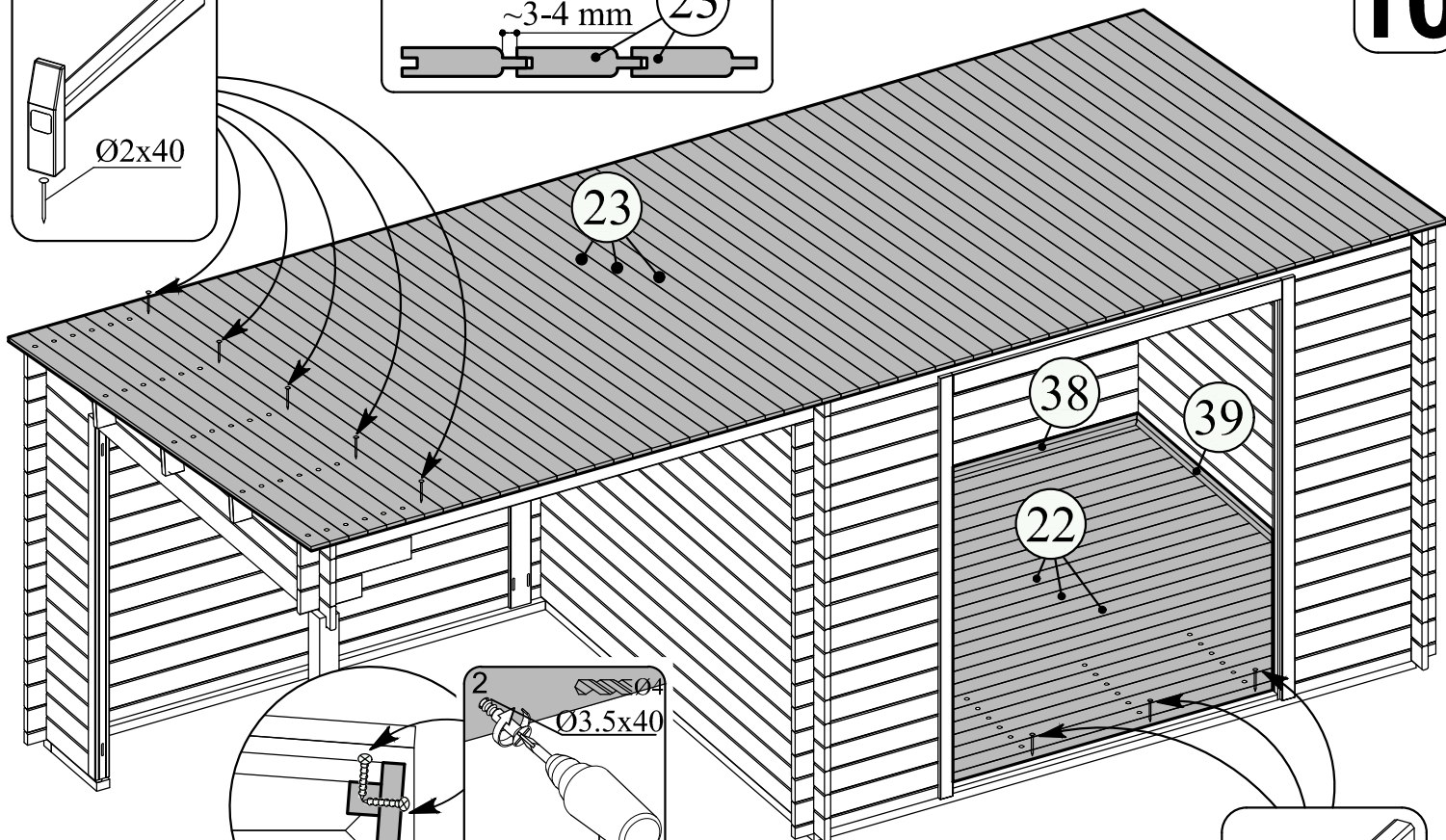
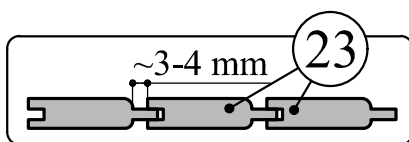
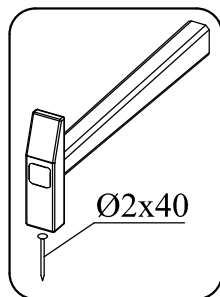

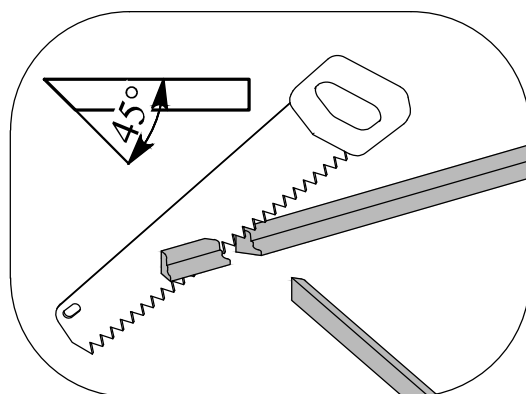
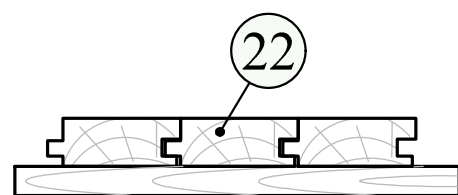
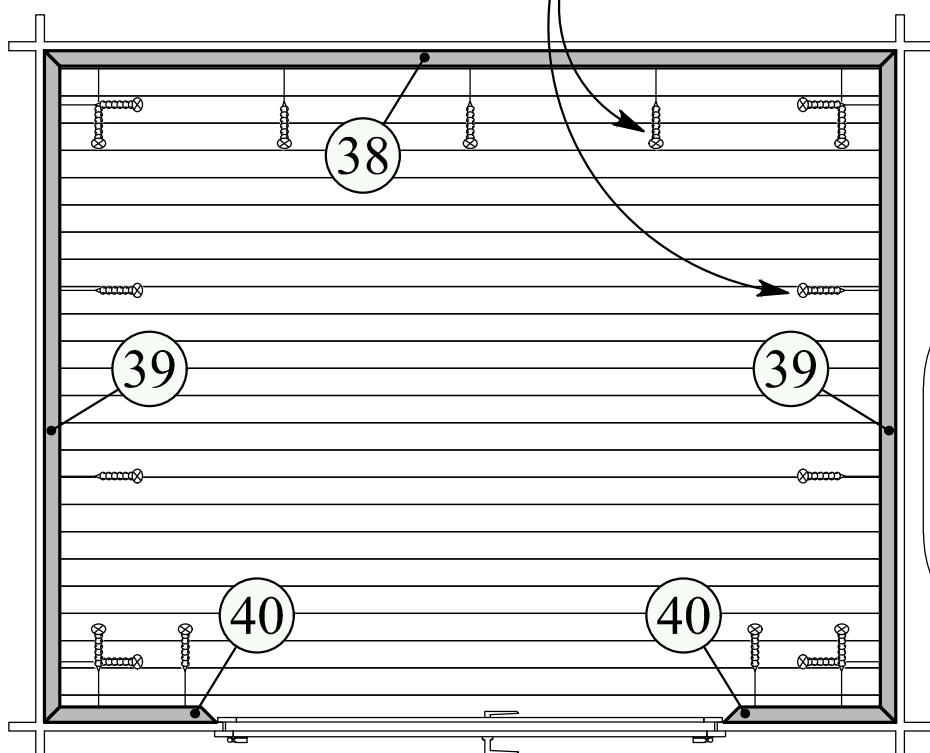
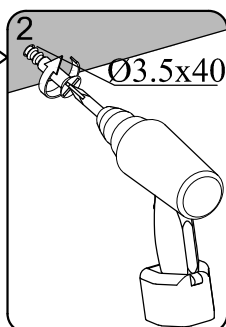
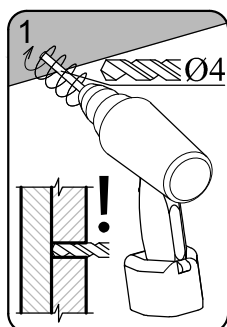
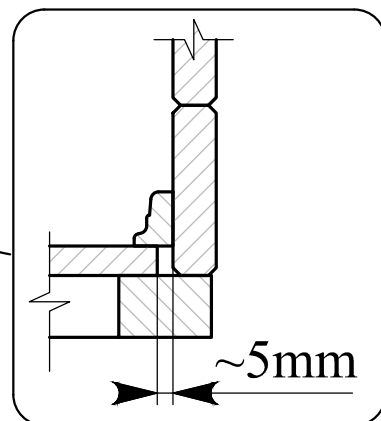
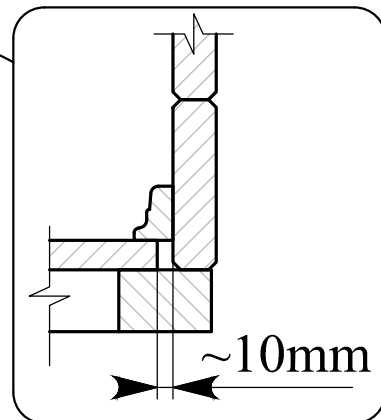
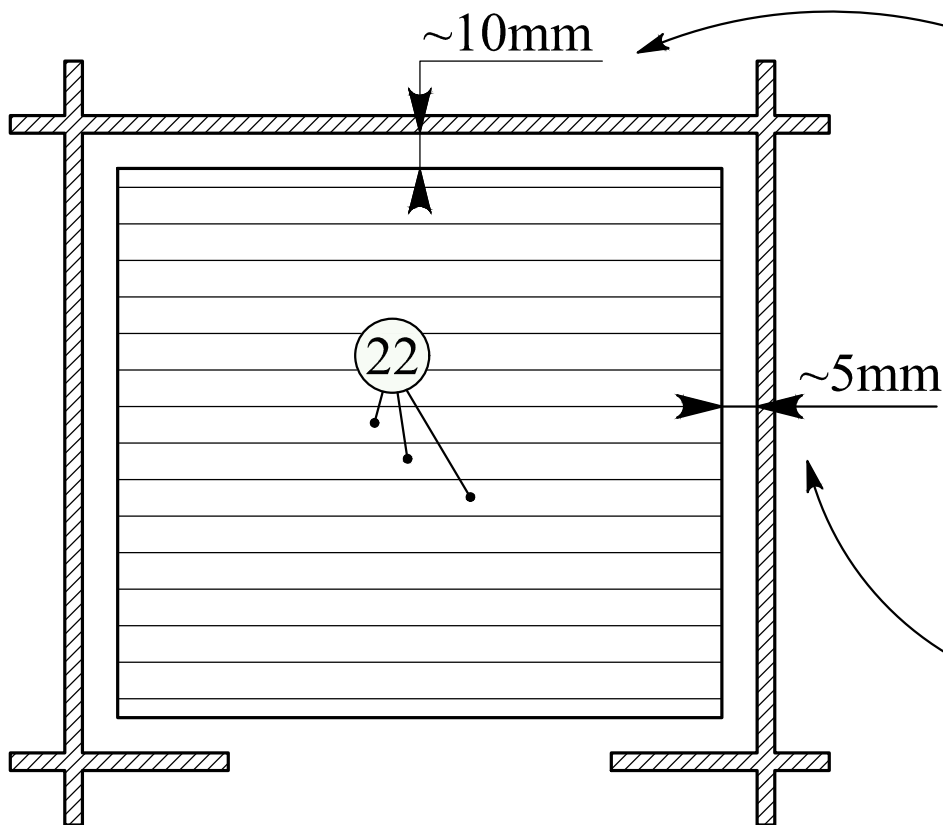

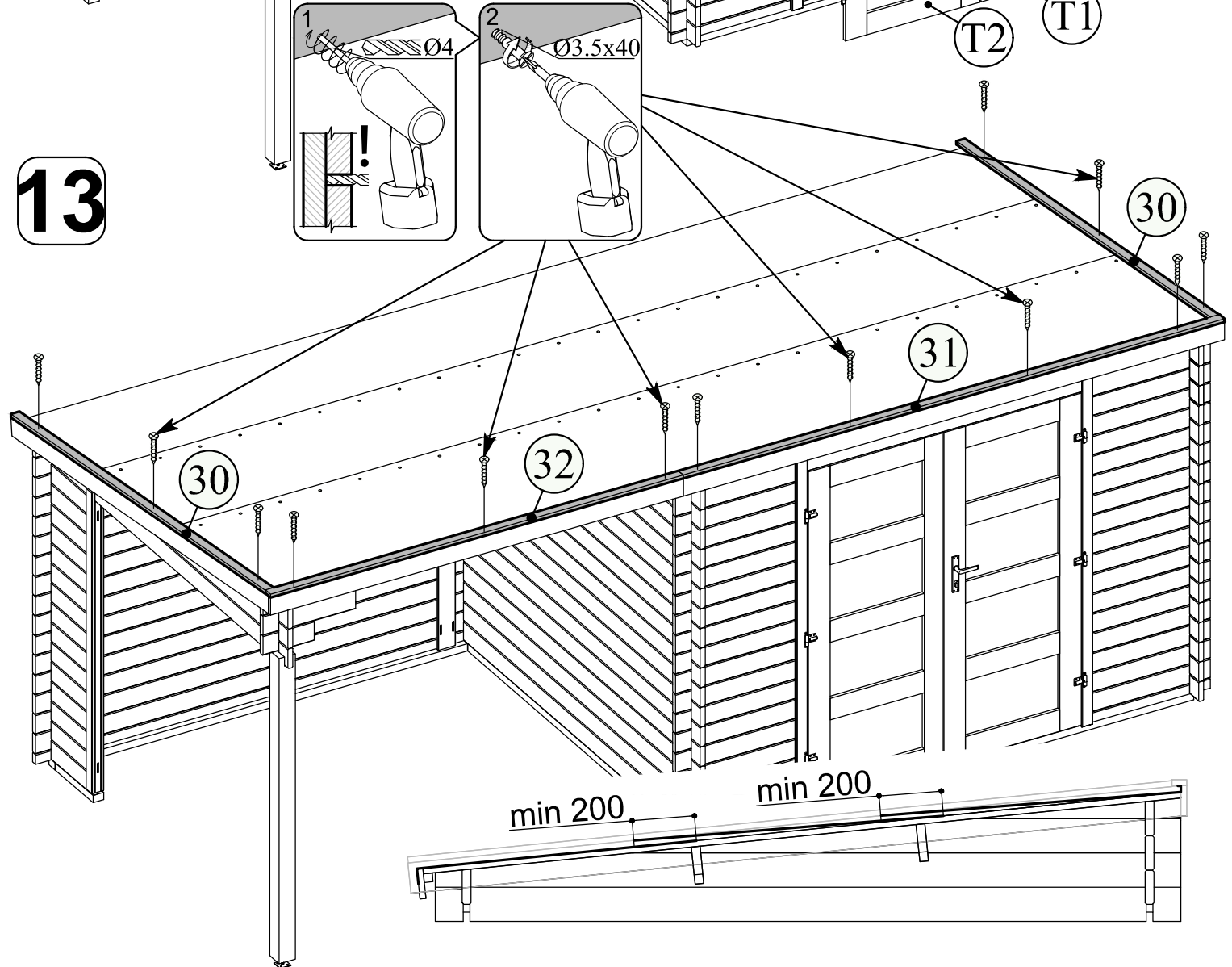
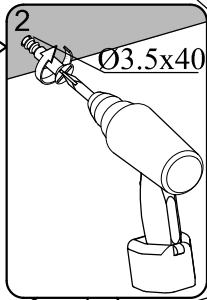
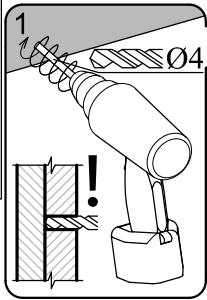
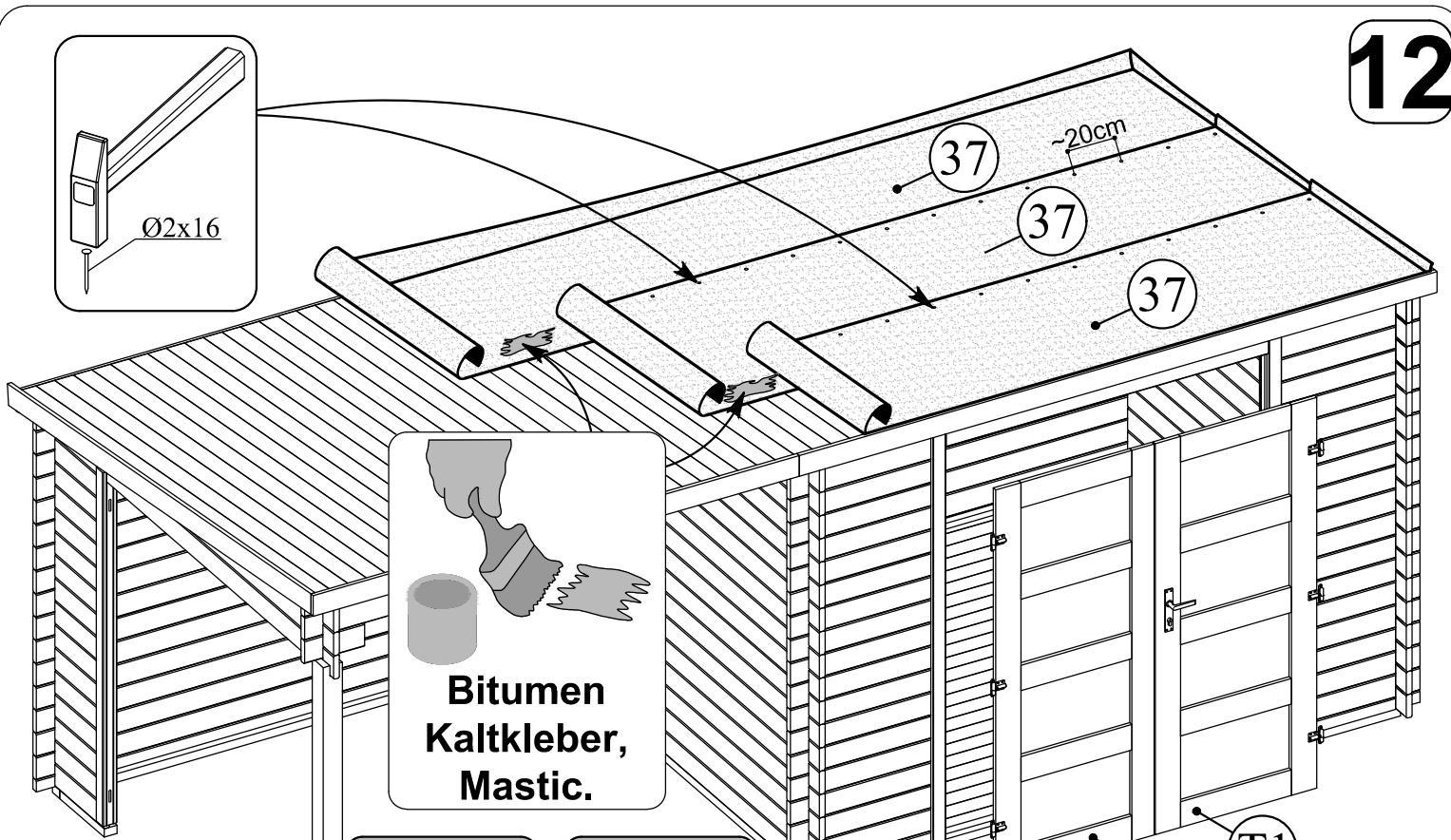
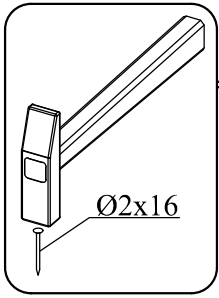

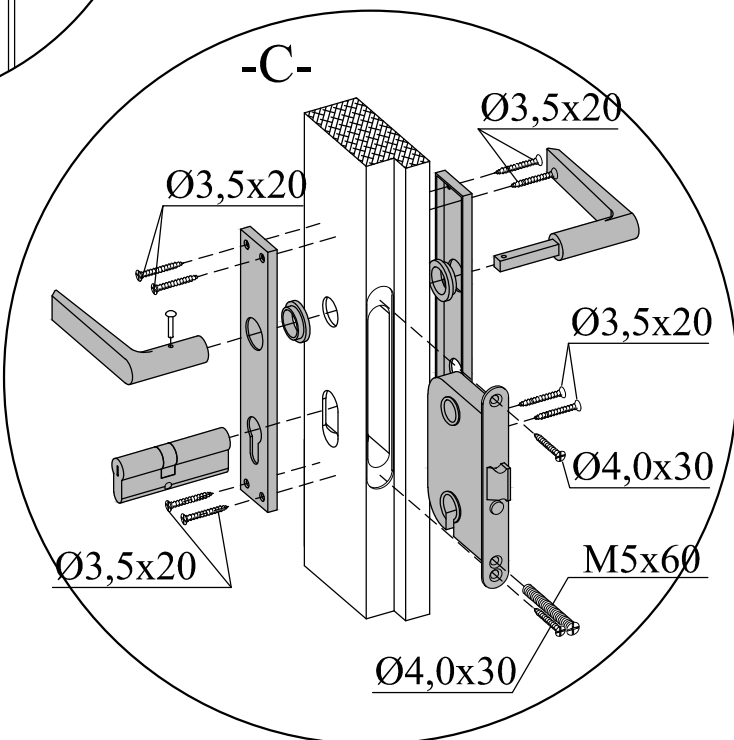
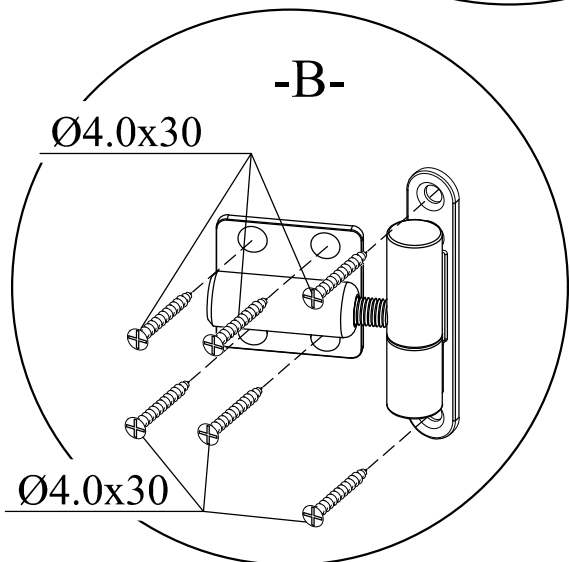
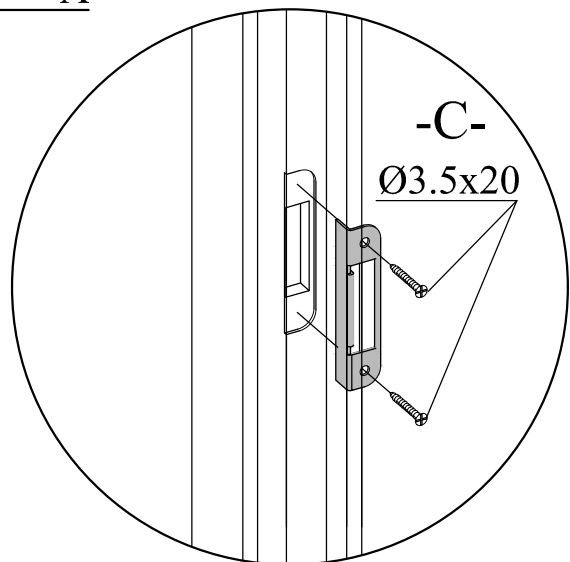
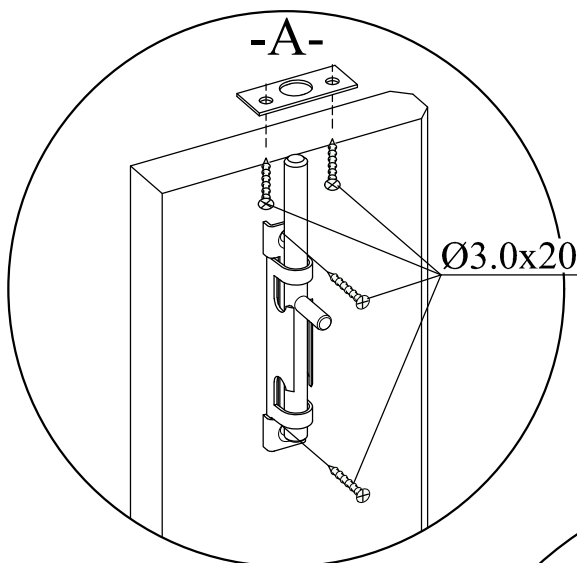
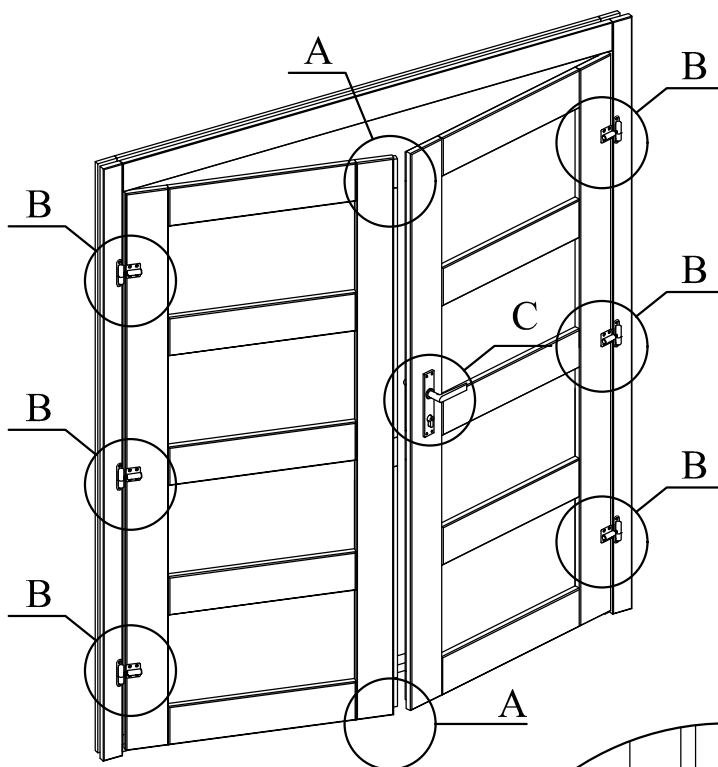

-B-

-1-

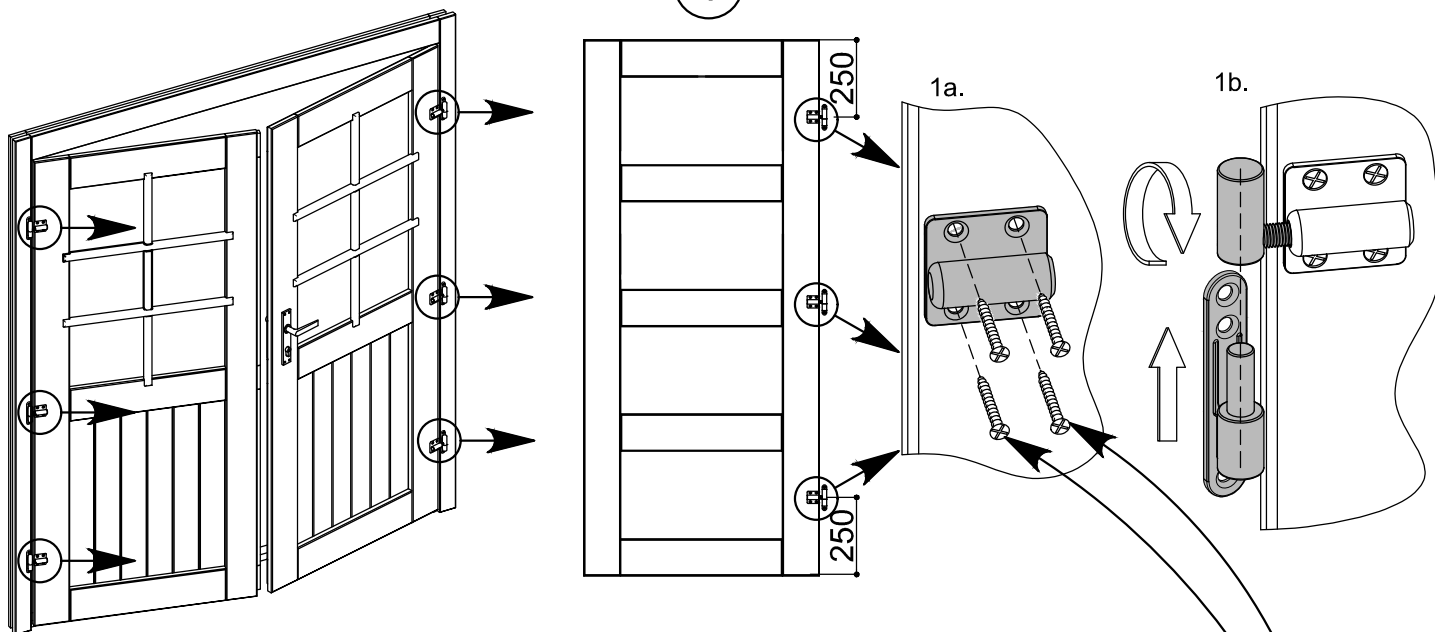

-2-

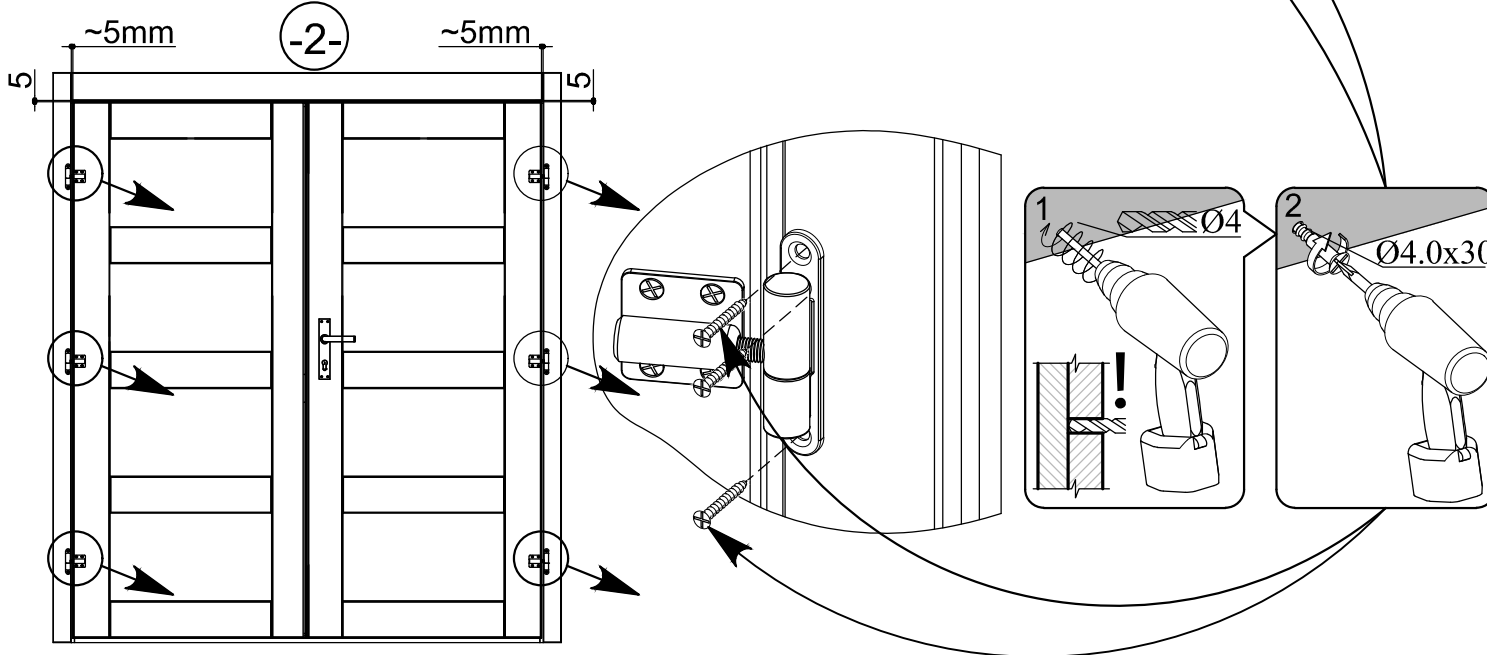

-3-

