

1/11









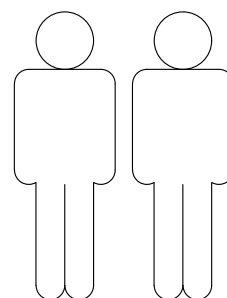
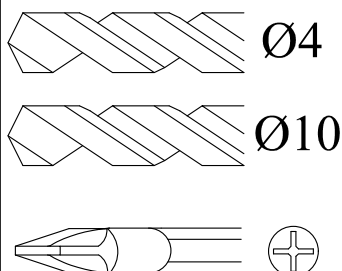
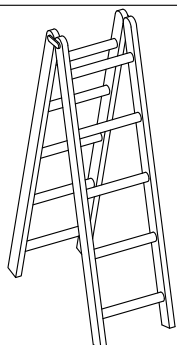
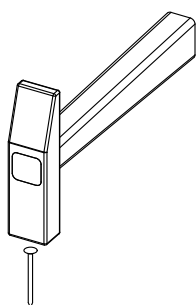
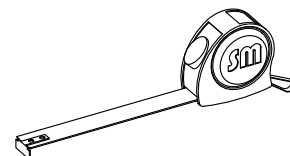
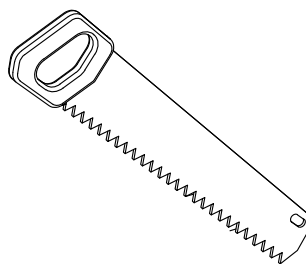
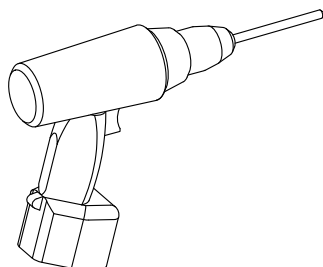
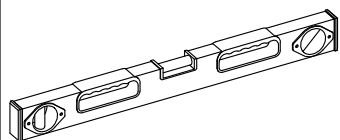
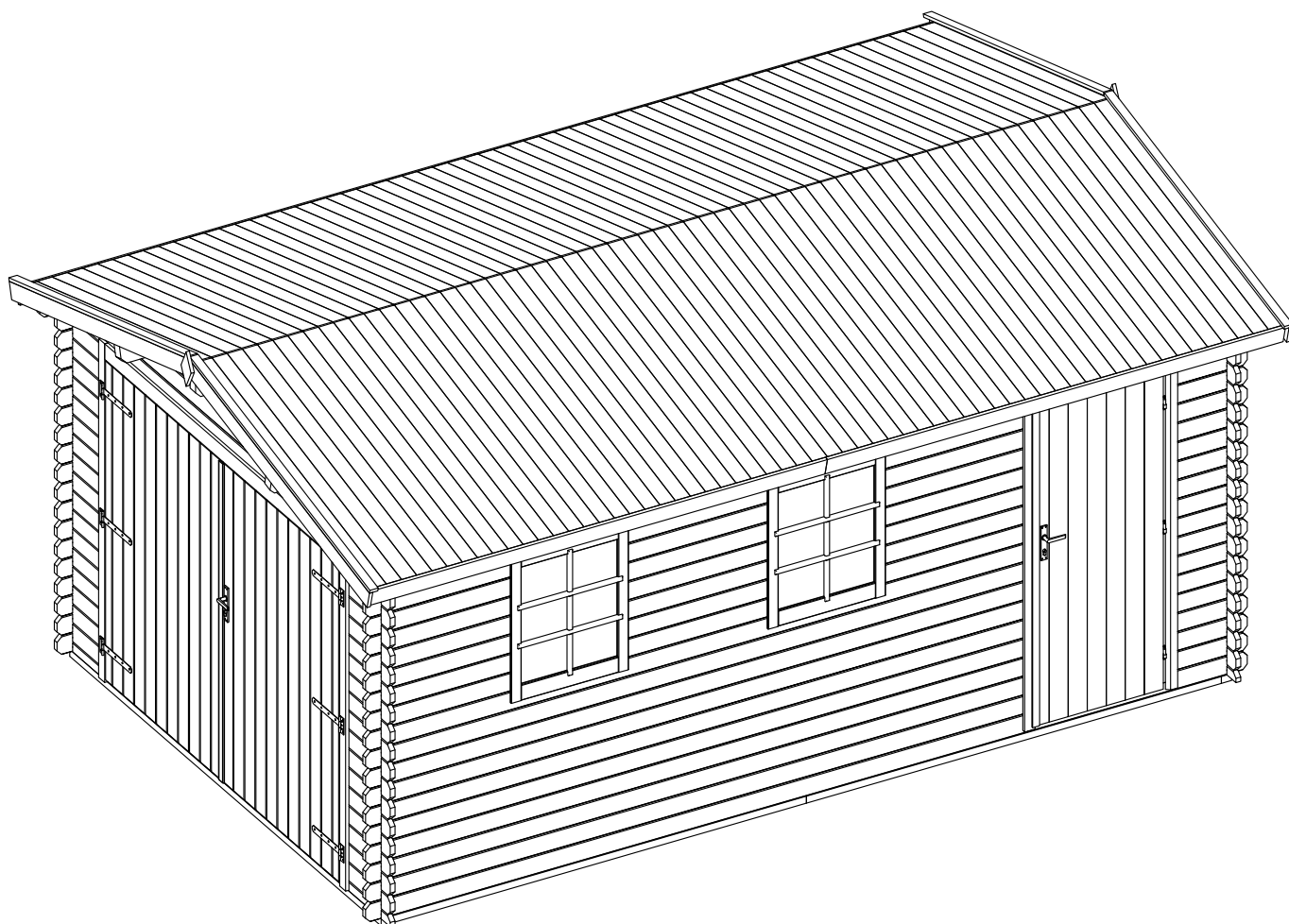

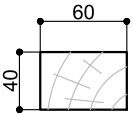
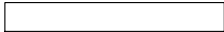
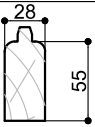

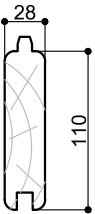
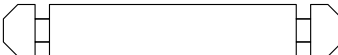
→||←28mm

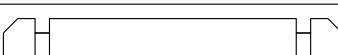
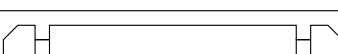
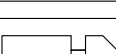
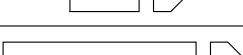
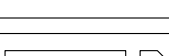
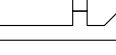
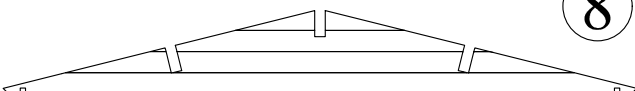
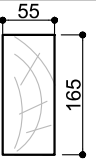

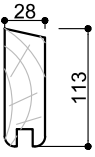

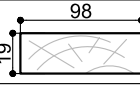
3,3 x 5,1

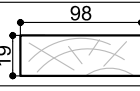
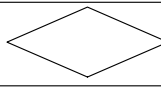
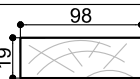
28040

ENG  
DE

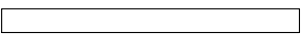
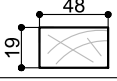
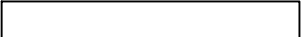
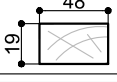
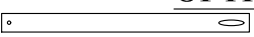
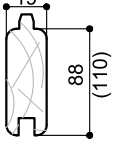



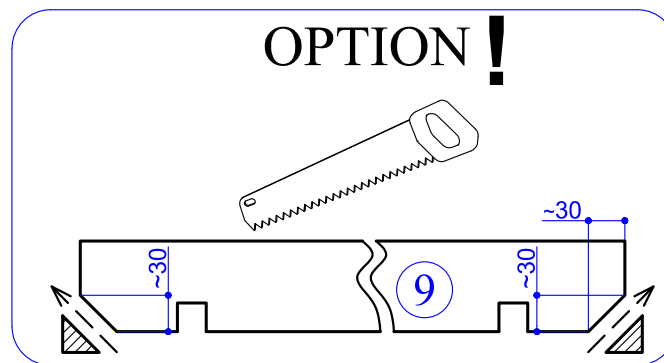

Dim.	Skizze, Sketch	Pos.	Länge, Length,mm	Stck/ Qté.	Name, Name	Ref.
		Ⓐ	3120	2	Fundamentbalken Foundation beam	283065
		Ⓑ	2400	4	Fundamentbalken Foundation beam	283080
		①	3300	2	Front/zurück Brett Front, Back board	280010
		②	5100	18+1	Seiten Brett Side board	280013
		②a	5100	1	Seiten Brett Side board	280153
		②b	5100	1	Seiten Brett Side board	280157
		③	3300	19+1	Front/zurück Brett Front, Back board	280012
		④	442	50	Front Brett Front Brett	280011
		⑤	3833	9	Seiten Brett Side board	280156
		⑥	857	7	Seiten Brett Side board	280154
		⑦	857	14	Seiten Brett Side board	280155
	⑧	3300	3	Front/zurück Brett Front, Back board	282027	
		⑨	5300	3	Strahl Rafters	284063
		⑩	5300	2	Seiten Brett Side board	281003
		⑪	1840	4	Wind Brett Wind Board	285062
		⑫	200	2	Decor Decor	286990
		⑬	2650	4	Wind Brett Wind Board	286047

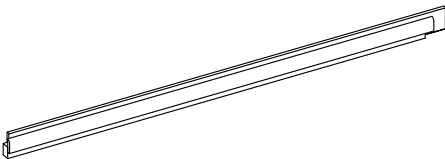
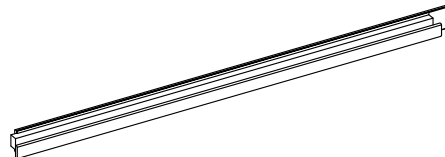
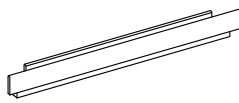
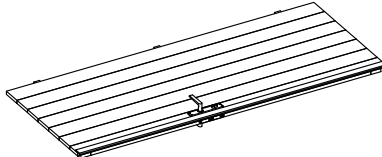
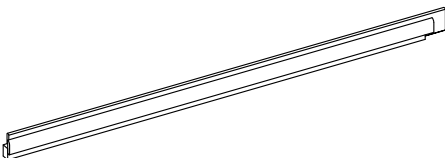
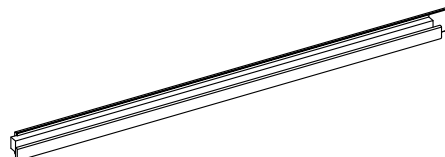
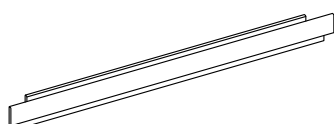
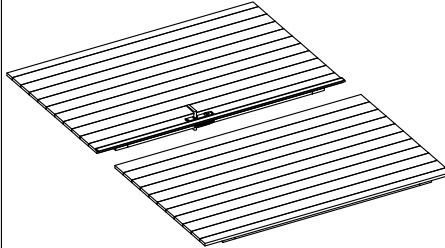
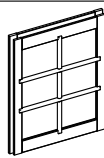
		14	2650	4	Wind Brett Wind Board	286048
		15	1840	4	Wind Brett Wind Board	286531
		!	2140	4	Latte Wind Board	286804
		10	1800	120+2 (96+2)	Dachbretter Roof Board	284512
		17	1835	1	Latte Latte	287106

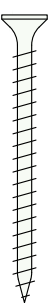
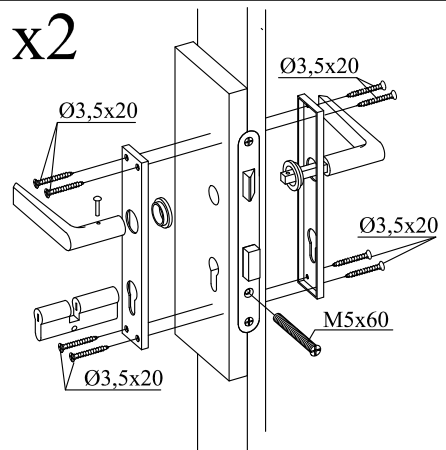
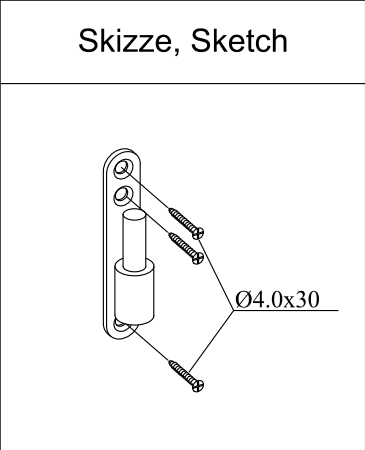

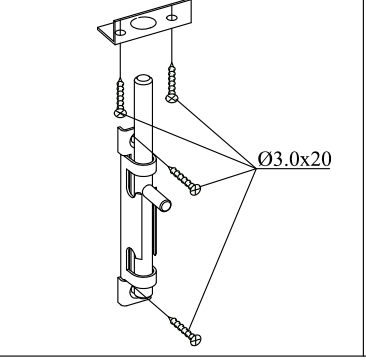
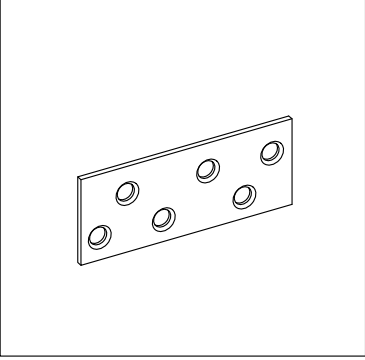
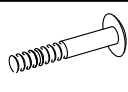
Skizze, Sketch	Pos.	Länge, Length,mm	Stck/ Qté.	Name, Name	Ref.
	TR1	1940	1	Türrahmen links Door frame left	289226
	TR2	1940	1	Türrahmen rechts Door frame right	289227
	TR3	910	1	Über Türrahmen Door frame top	289228
	T	1845x 760	1	Tür Doors	289013
	GR1	1960	1	Türrahmen links Door frame left	289212
	GR2	1960	1	Türrahmen rechts Door frame right	289213
	GR3	2405	1	Über Türrahmen Door frame top	289214
	G1	1845x 1170	1	Tür Doors	289009 G1
	G2	1845x 1170	1		289009 G2
	F	700x880	2	Fenster Window	289101

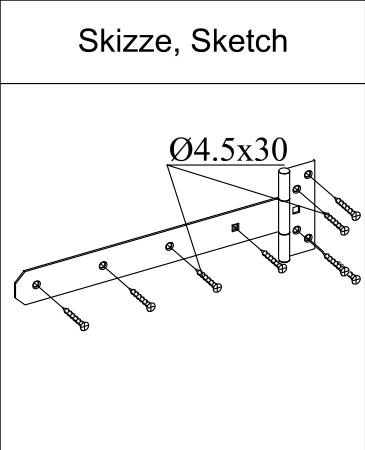
	Pos.	Dim	Qté.		Skizze, Sketch	Qté.		
	<b>A</b>	Ø5.0 x 100	8	<b>x2</b> 		<b>3</b>		
	<b>B</b>	Ø3.5 x 40	84					
		Ø3.0 x 25	4					
				Skizze, Sketch	Qté.	Skizze, Sketch	Qté.	
	<b>C</b>	Ø2.0 x 40	360		<b>2</b>		<b>2</b>	
		M8 x 60	4					
			8					
		M8	4					
					Skizze, Sketch	Qté.	Skizze, Sketch	Qté.
						<b>6</b>		

1

60

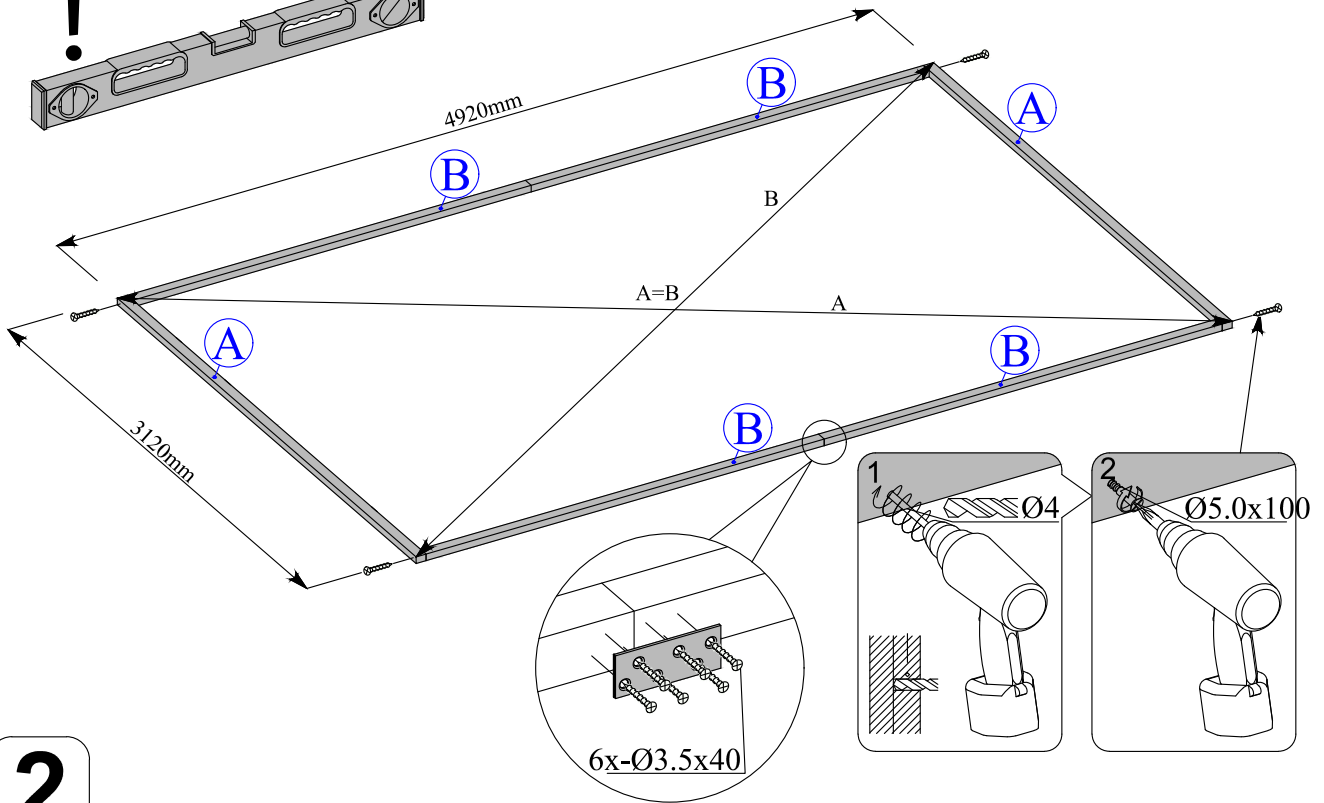
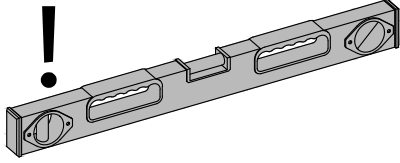

2

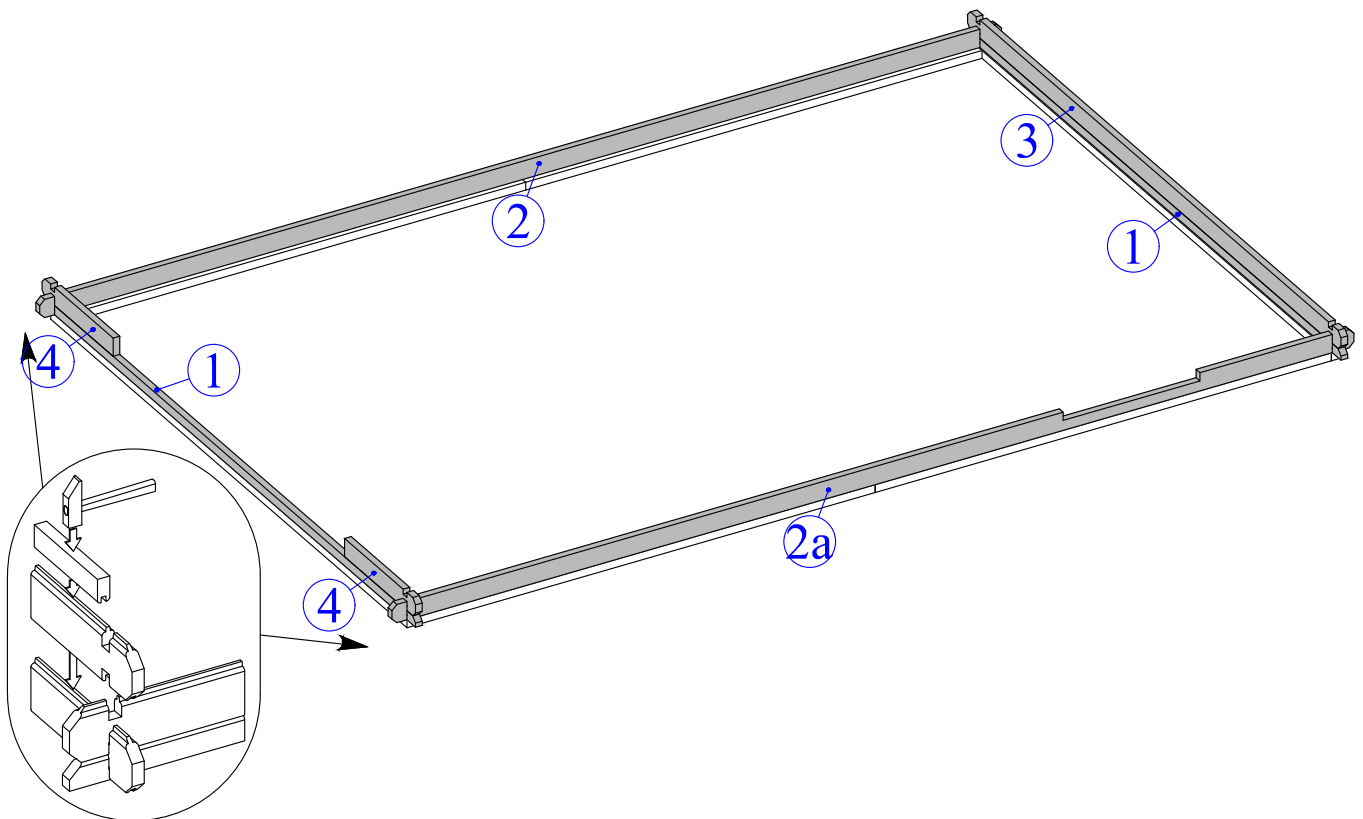

3

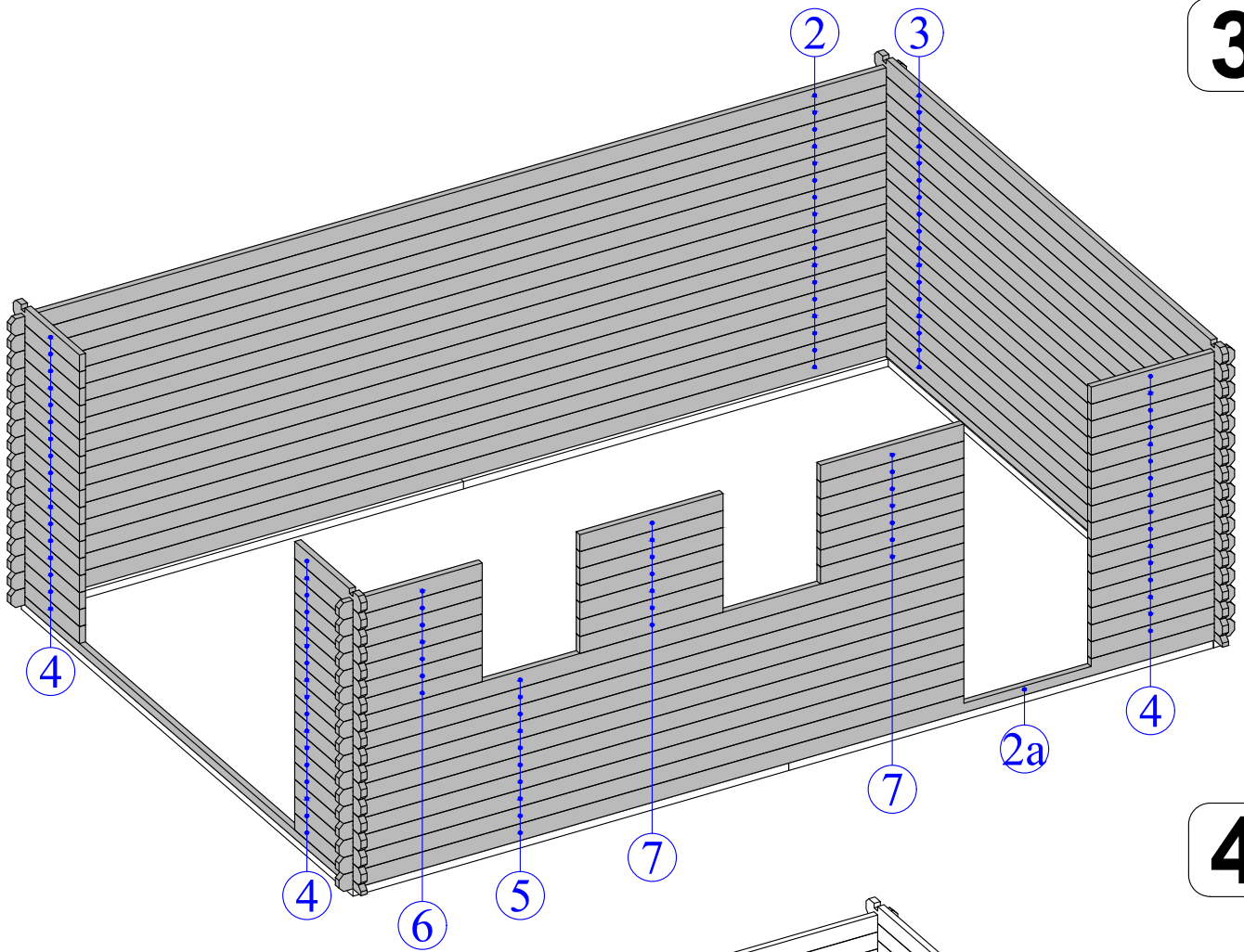

4

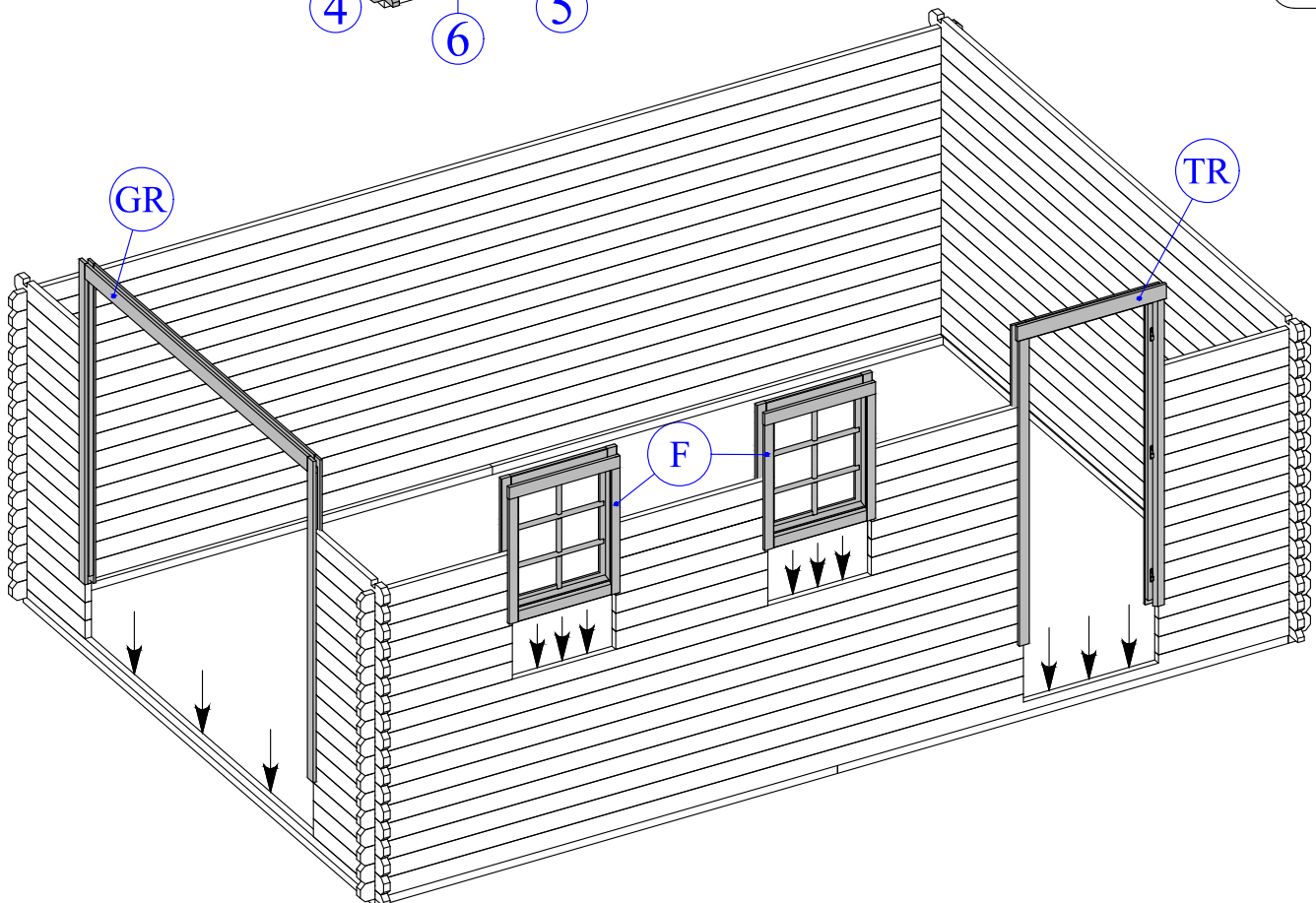

Möglichkeit schauen auf Seite 3

5

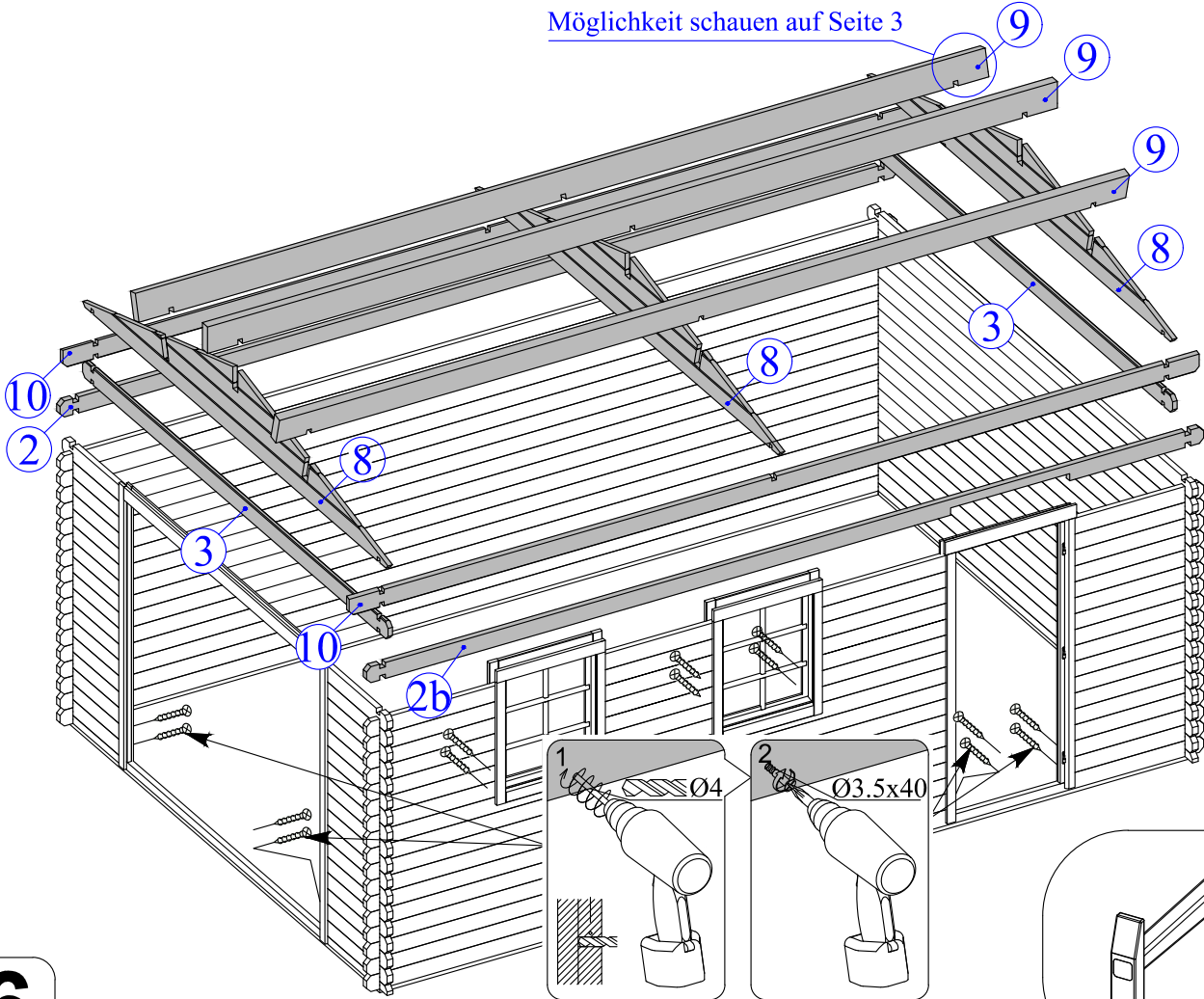

6

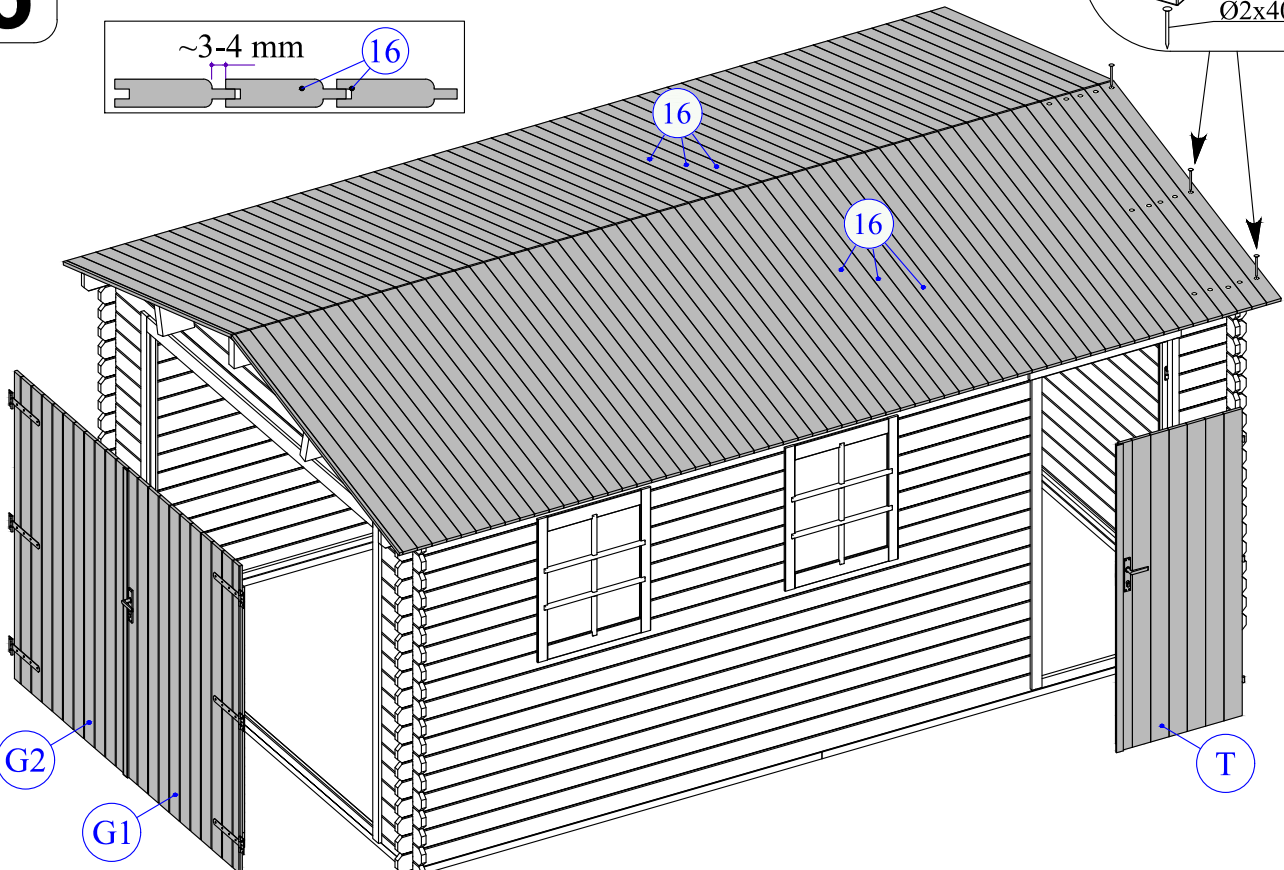
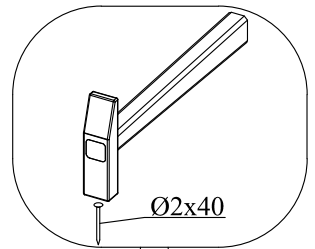
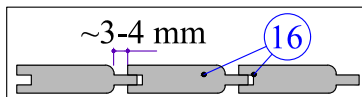

7

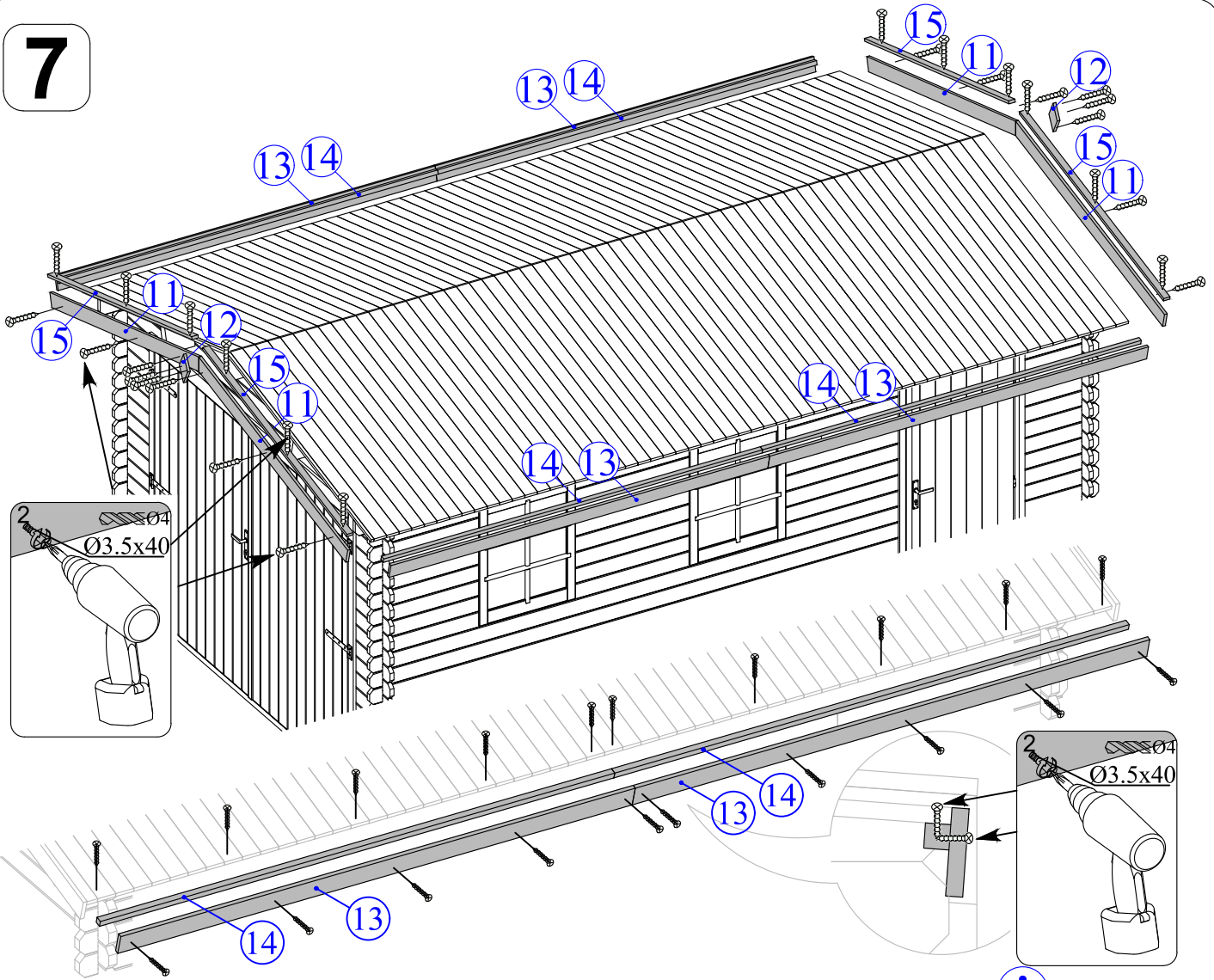

8

