

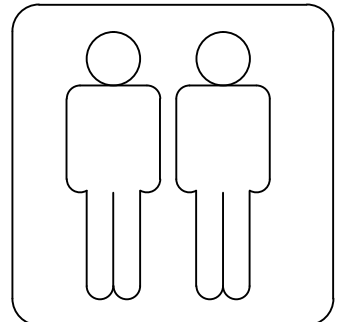

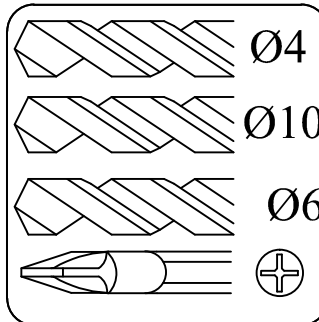

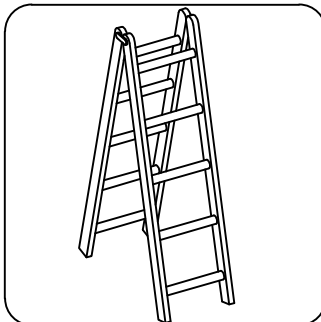

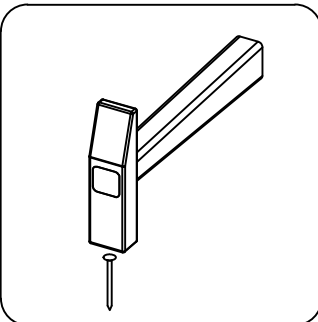

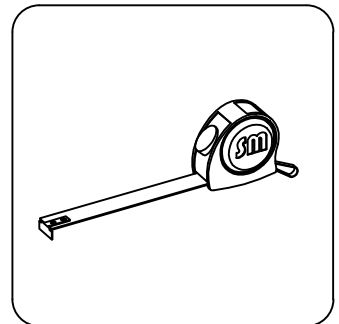
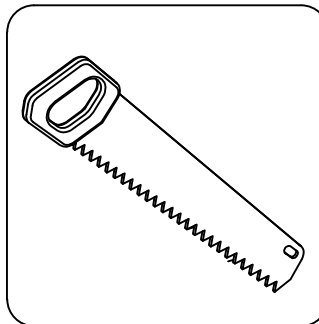
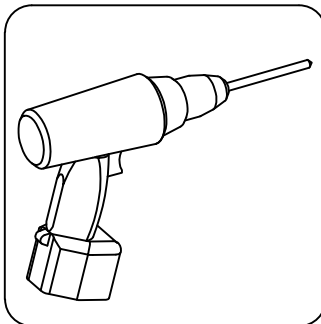
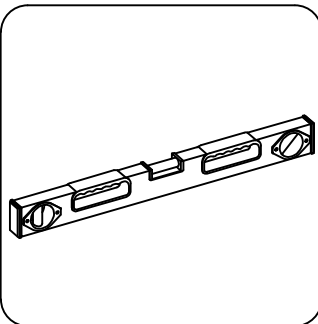
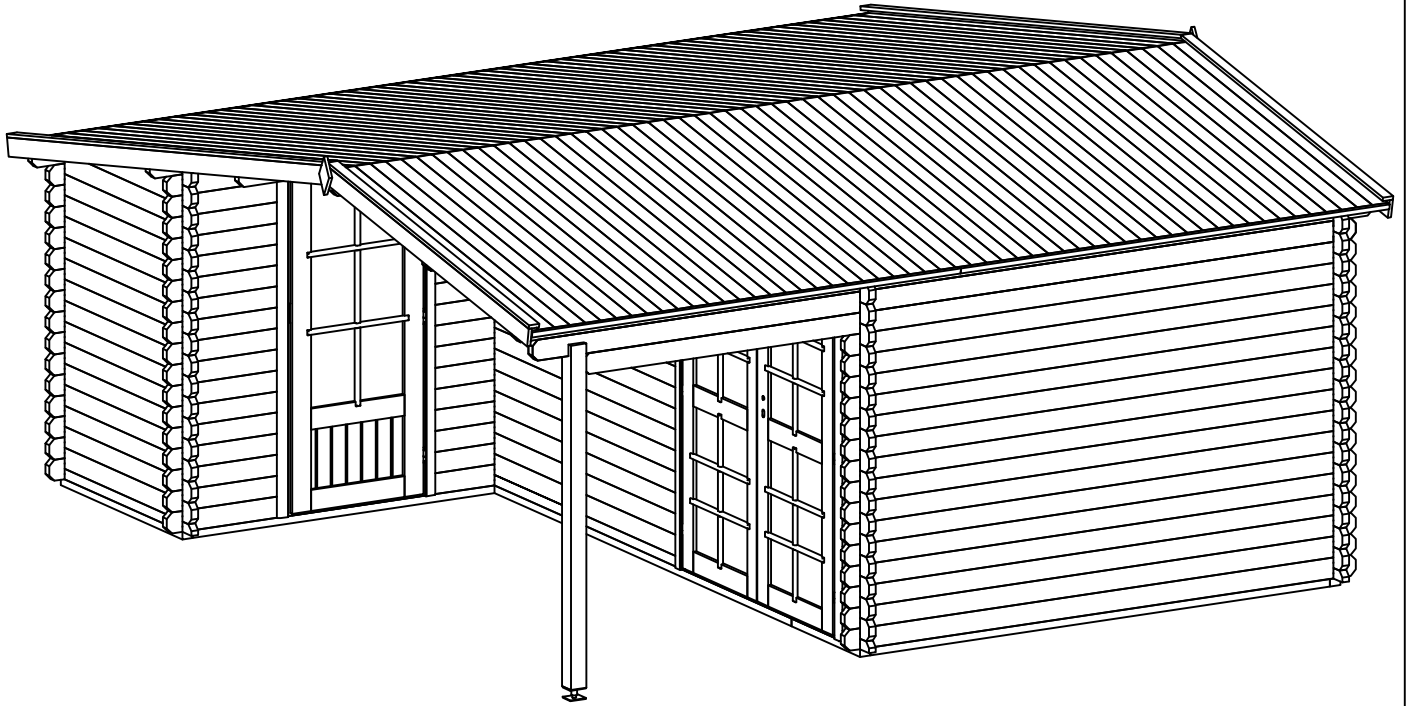

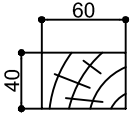
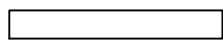
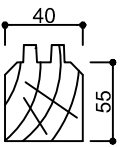
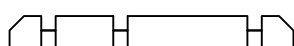
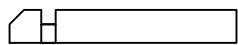
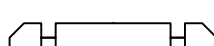
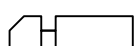
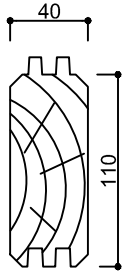
→||←40mm

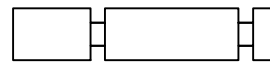
5,1 x 4,8/2,98

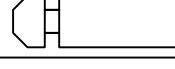
40005

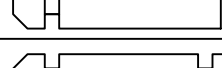
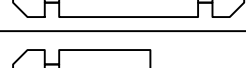
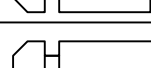

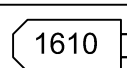
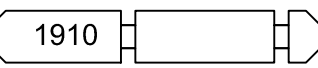
→ || ← 40mm SPECIFICATION 5,1 x 4,8/2,98 **40005**

Dim.	Skizze, dessin, Sketch	Pos.	Länge, Longueur, Length, mm	Quantity Quantitat Quantite	Name, Nom, Name	Ref.
		①	3000	5	OPTION Fundamentbalken Lambourdes Foundation beam	283039
		②	2680	8		283002
		③	1500	3		283037
		④	1228	1		283022
		⑤	1920	1		283086
		⑥	692	1		283087
		⑦	400	4		283084
		⑧	5100	1	Zurück Brett Madrier arriere Back board	400041
		⑨	2000	1	Front Brett Madrier avant Front board	400035
		⑩	1408	1	Front Brett Madrier avant Front board	400033
		⑪	285	1	Front Brett Madrier avant Front board	400038
		⑫	4800	8	Seiten Brett Madrier lateral Side board	400006
		⑬	3265	17	Mitte Brett Madrier milieu Middle board	400249
		⑭	2980	15	Seiten Brett Madrier lateral Side board	400121
		⑮	680	31	Seiten/Mitte Brett Madrier lateral/milieu Side board/Middle	400247
		⑯	5100	15	Zurück Brett Madrier arriere Back board	400042
		⑰	2000	10	Front Brett Madrier avant Front board	400036
		⑱	1408	15	Front Brett Madrier avant Front board	400034
		⑲	285	17	Front Brett Madrier avant Front board	400039
		⑳	3490	7	Front Brett Madrier avant Front board	400248
		㉑	690	7	Front Brett Madrier avant Front board	400250
		㉒	4500	1	Seiten Brett Madrier lateral Side board	400046
		㉓	4800	1	Seiten Brett Madrier lateral Side board	400047

Alle maen ca +/-3% / les dimensions des pies peuvent voluer +/- 3%

→ || ← 40mm

SPECIFICATION





5,1 x 4,8/2,98

40005

Dim.	Skizze, dessin, Sketch	Pos.	Länge, Longueur, Length, mm	Quantity Quantität	Name, Nom, Name	Ref.
		24a	5000	1	Seiten Brett Madrier latéral Side board	401008a
		24b	5000	1	Seiten Brett Madrier latéral Side board	401008b
		25	5000	1	Seiten Brett Madrier latéral Side board	401009
		26a	5000	1	Seiten Brett Madrier latéral Side board	401007a
		26b	5000	1	Seiten Brett Madrier latéral Side board	401007b
		27	5100	1	Seiten Brett Madrier latéral Side board	402009
		28	4700	1	Seiten Brett Madrier latéral Side board	402010
		29	1408	1	Front Brett Madrier avant Front board	402006
		30	1003	1	Front Brett Madrier avant Front board	402007
		31	412	1	Front Brett Madrier avant Front board	402008
32a			4100	1	Zurück Brett Madrier arrière Back board	402011
32b			3900	1	Front Brett Madrier avant Front board	402005
		33	5000	1	Sparren Panne faîtière Rafters	404010
		34a	5000	1	Sparren Panne faîtière Rafters	404011
		34b	5000	1		404012
		35	1800	1	Strut Pavaner Unterstützung	287102
		36	3270	56	Dach Bretter Madrier de toit Roof board	284509
		37	2050	56		284502

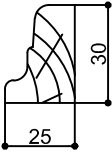
Alle maßen ca +/- 3% / les dimensions des pièces peuvent évoluer +/- 3% / size tolerance +/- 3%

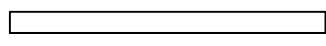
→ || ← 40mm SPECIFICATION 5,1 x 4,8/2,98 **40005**

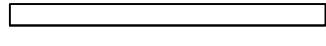
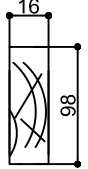
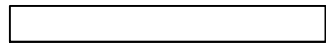
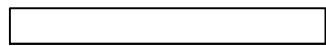
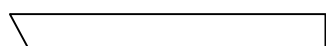
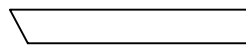
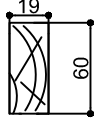
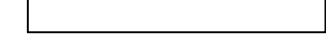
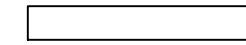
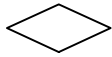
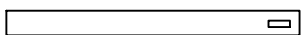
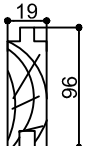
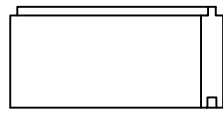
Dim.	Skizze, dessin, Sketch	Pos.	Länge, Longueur, Length, mm	Quantity, Quantité	Name, Nom, Name	Ref.
		38	1148	2	<p style="text-align: center;">OPTION</p> <p style="text-align: center;">Bodenleiste Lame de plancher Skirting board</p>	283282
		39	2720	3		283254
		40	3000	2		283283
		41	1540	1		283233
		42	1830	1		283284
		43	500	1		283250
		44	3400	1		283285
		45	130	1		283281
		46	652	1		283286
		47	3000	2	Dach Latte Lame de toit Roof lath	286039
		47a	2000	2	Dach Latte Lame de toit Roof lath	286041
		47b	3000	2	Dach Latte Lame de toit Roof lath	286038
		47c	2000	2	Dach Latte Lame de toit Roof lath	286040
		48	2070	2	Wind Brett Planche de rive Wind board	285002
		49	3290	2		285013
		50	2070	2	Wind Brett Planche de rive Wind board	286503
		51	3290	2		286509
		52		2	Decor	286990
19x45		53	2000	4		286801
		54	1142	52	<p style="text-align: center;">OPTION</p> <p style="text-align: center;">Boden Bretter Plancher bois Floor board</p>	283505
		55	3630	31		283515



Alle maßen ca +/- 3% / les dimensions des pièces peuvent évoluer +/- 3% / size tolerance +/- 3%

→||←40mm



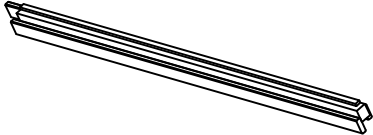

SPECIFICATION

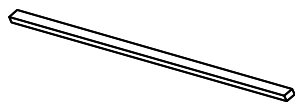
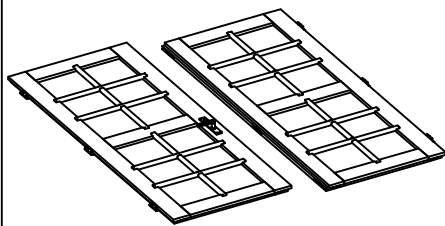
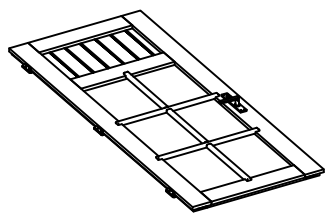
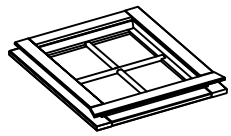
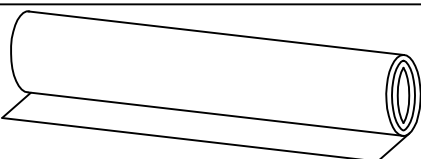
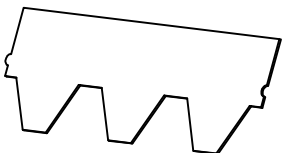
5,1 x 4,8/2,98

40005

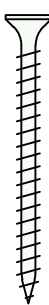
	TR1	1973	1	Türrahmen links Cadre de porte gauche Door frame left	409224
	TR5	1973	1		409228
	TR2	1973	1	Türrahmen rechts Cadre de porte droite Door frame right	409225
	TR6	1973	1		409225
	TR3	1700	1	Über Türrahmen Montant supérieur Door frame top	409226
	TR7	945	1		409229
	TR4	1500	1	Türstufe Latte de finition bas Door frame bottom	409227
	TR8	745	1		409230
	T1	1850x 765	1	Tür Porte Doors	289004 T1
	T2	1850x 765	1		289006 T2
	T3	1850x 765	1	Tür Porte Doors	289012 T3
	F1	760x 880	2	Fenster Fenêtre Window	409108
			5.1m	6	OPTION Feutre bitumé
				11	OPTION Shingle

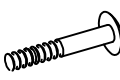
Alle maßen ca +/-3% / les dimensions des pièces peuvent évoluer +/- 3% / size tolerance +/- 3%

	Pos.	Dim	Stck.
	A	Ø4.5 x 100	50
	B	Ø3.5 x 35	130
	C	Ø4.0 x 60	3
	C	Ø2.0 x 40	410
	D	Ø2.0 x 50	410
		M8 x 60	4
			8
		M8	4

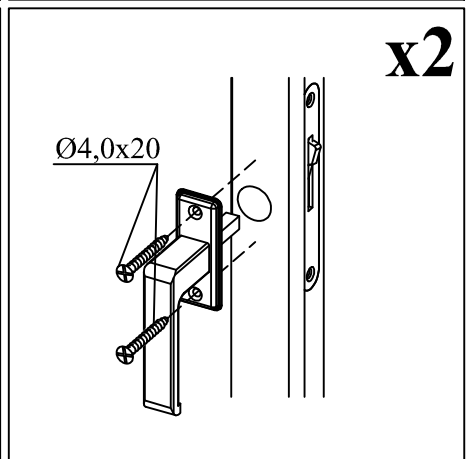
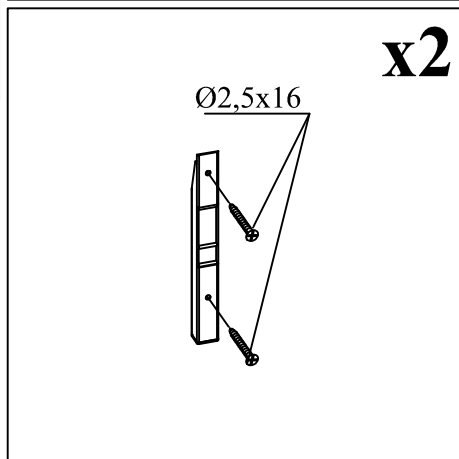
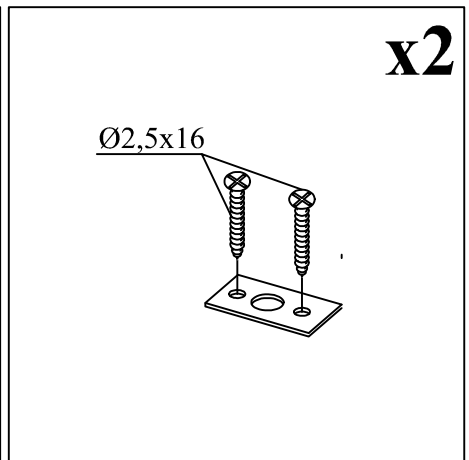
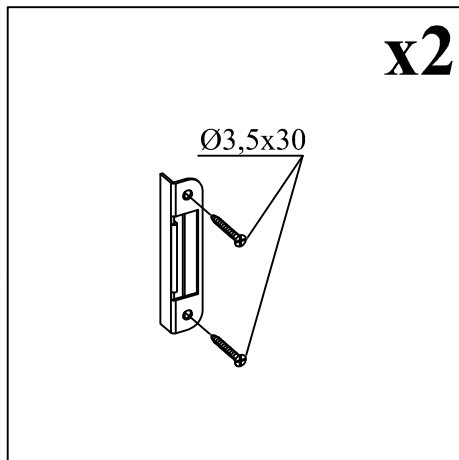
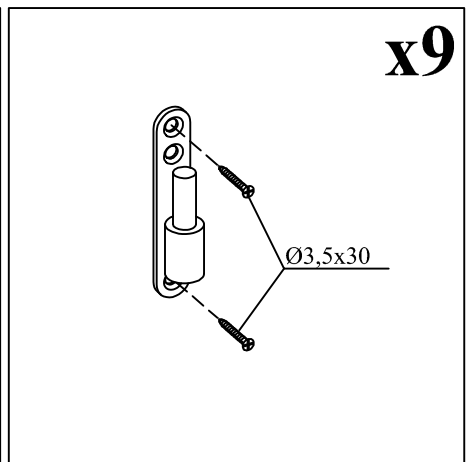
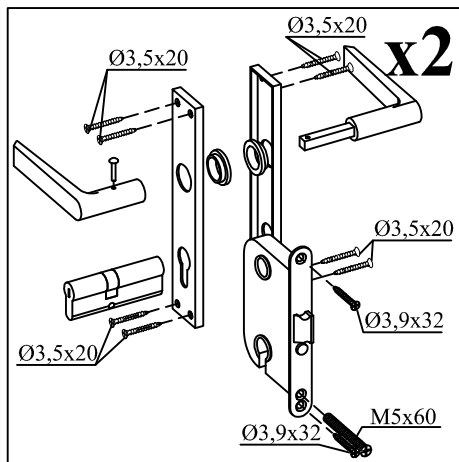

→||←40mm

5,1 x 4,8/2,98

40005

1

OPTION

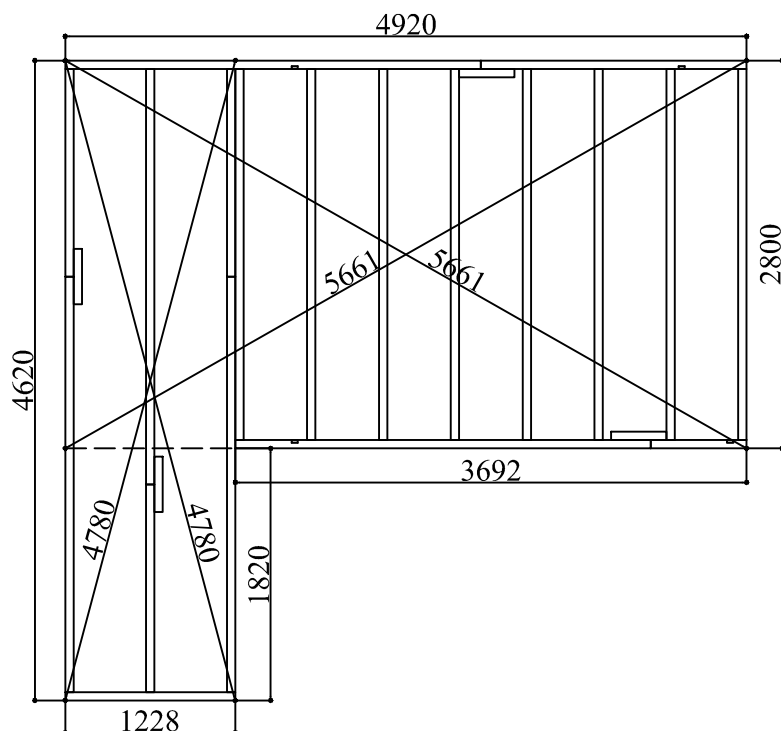
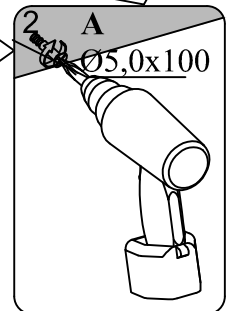
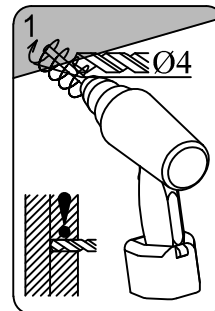
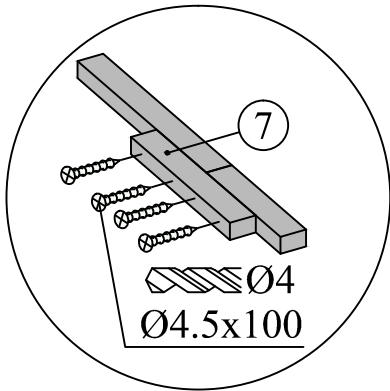
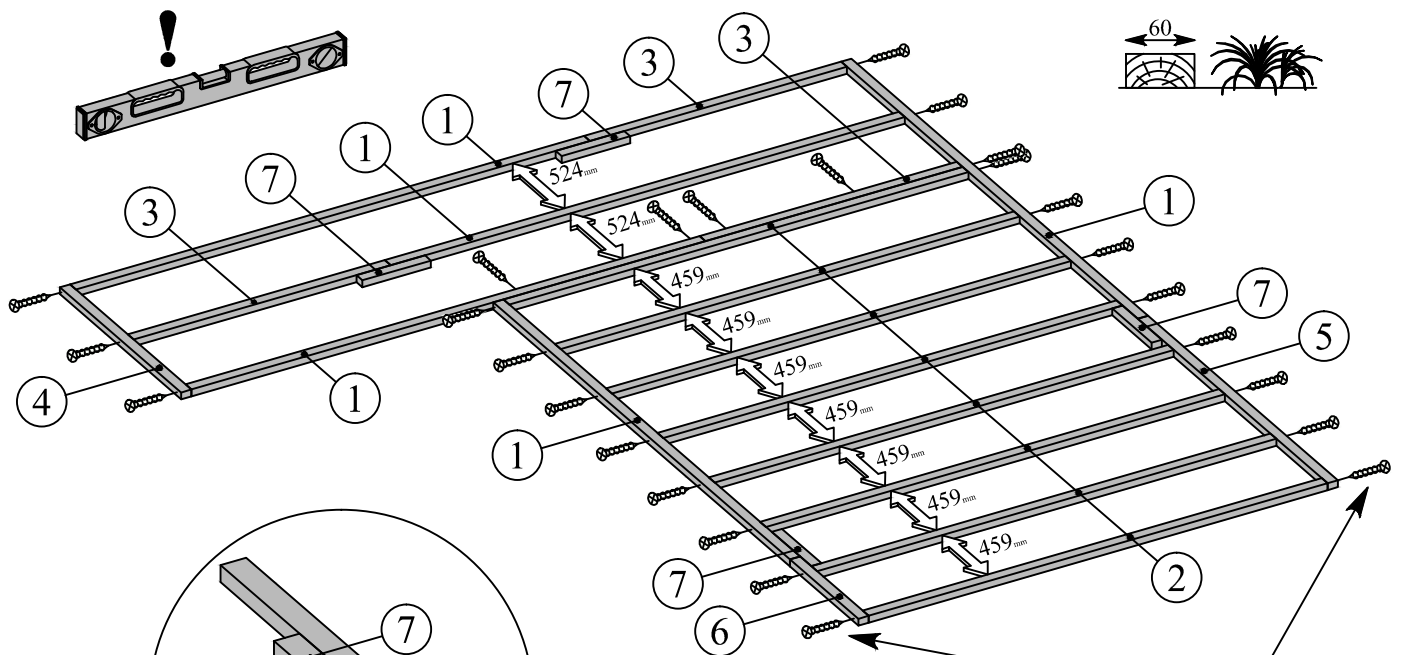

Montage variante
Assembling variant
Des option de montage

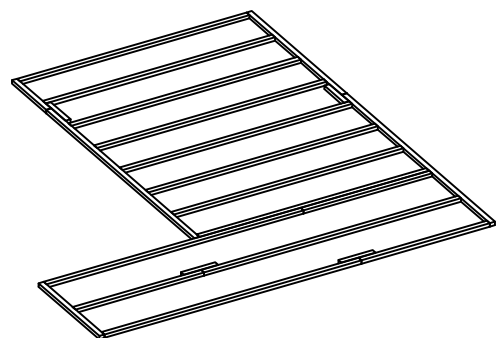

→||←40mm

5,1 x 4,8/2,98

40005

2

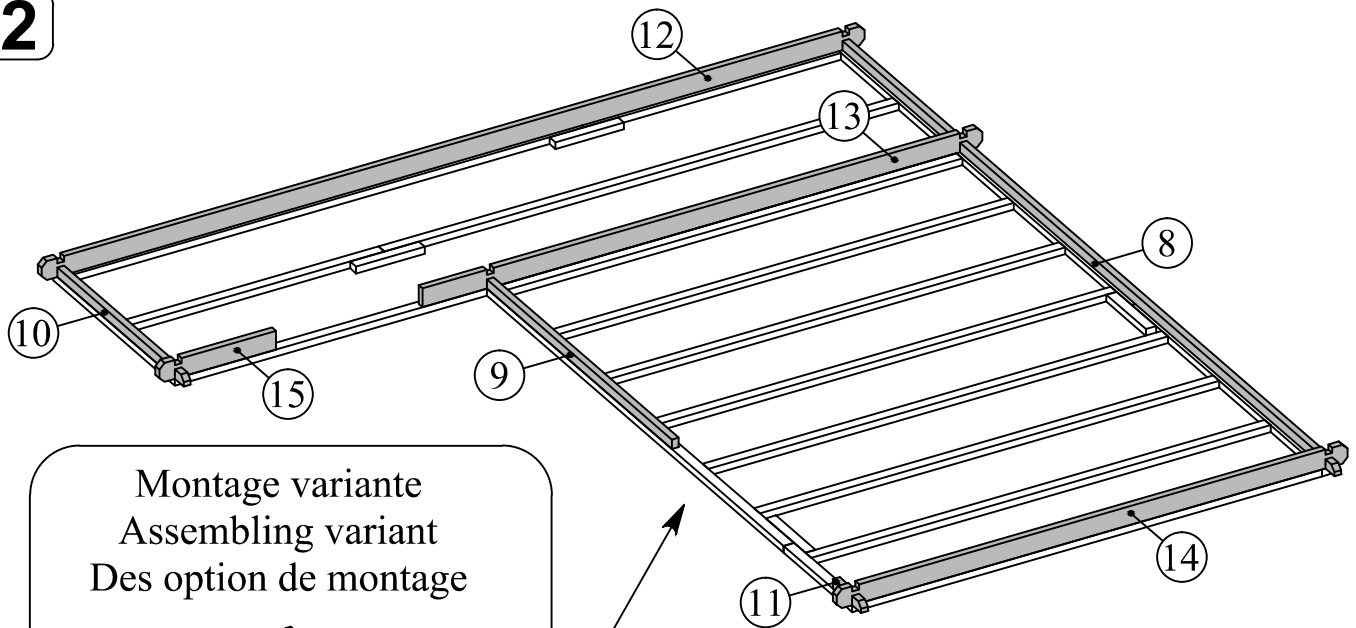

Montage variante
Assembling variant
Des option de montage

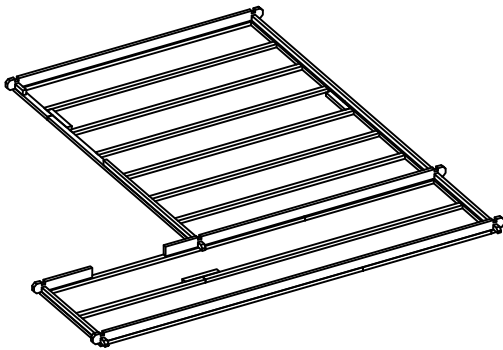

Montage variante
Assembling variant
Des option de montage

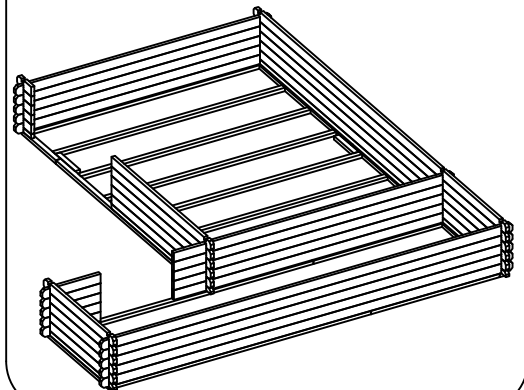

3

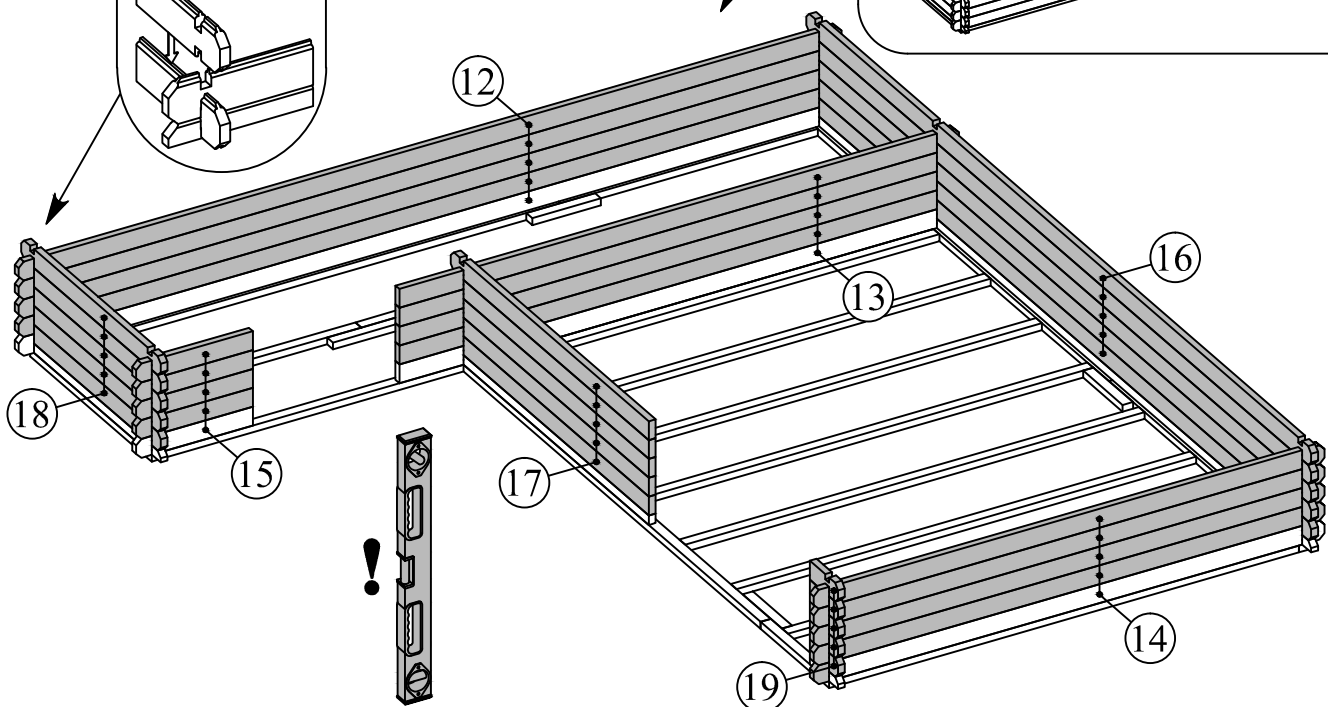
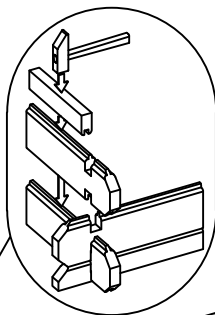

→||←40mm

5,1 x 4,8/2,98

40005

4

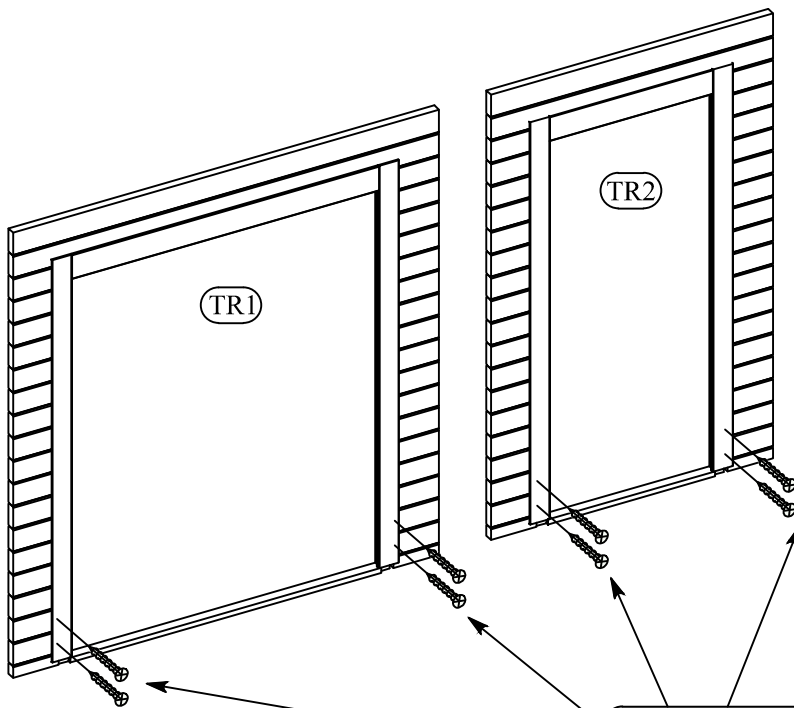
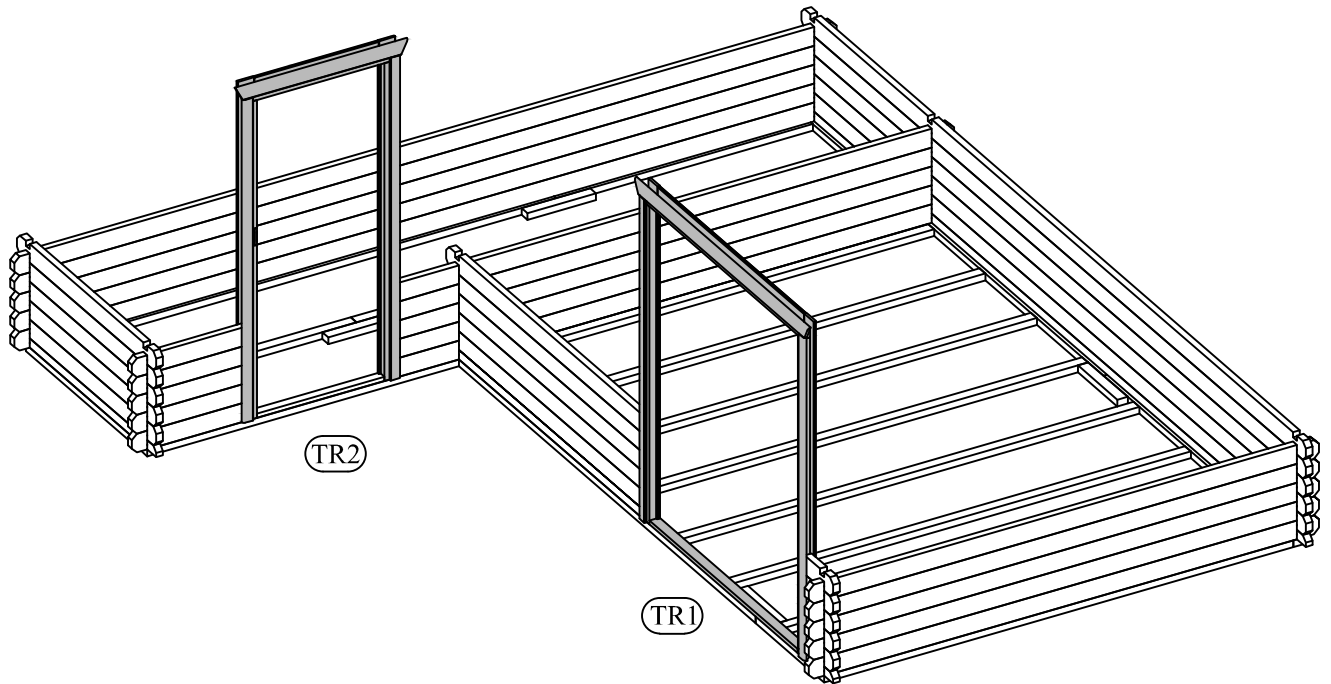

Montage variante
Assembling variant
Des option de montage

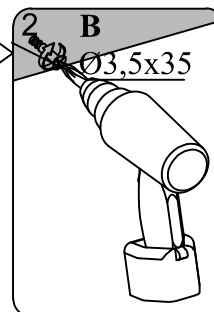
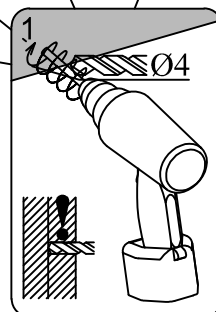
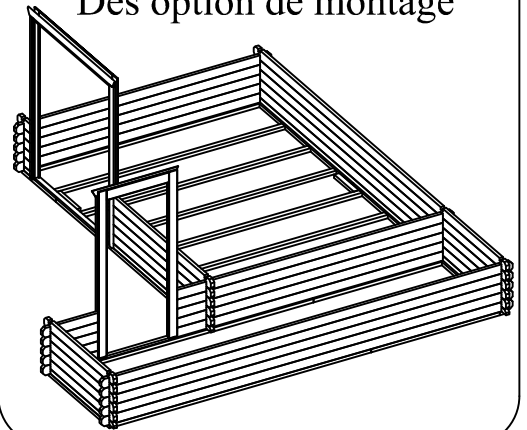

→||←40mm

5,1 x 4,8/2,98

40005

5

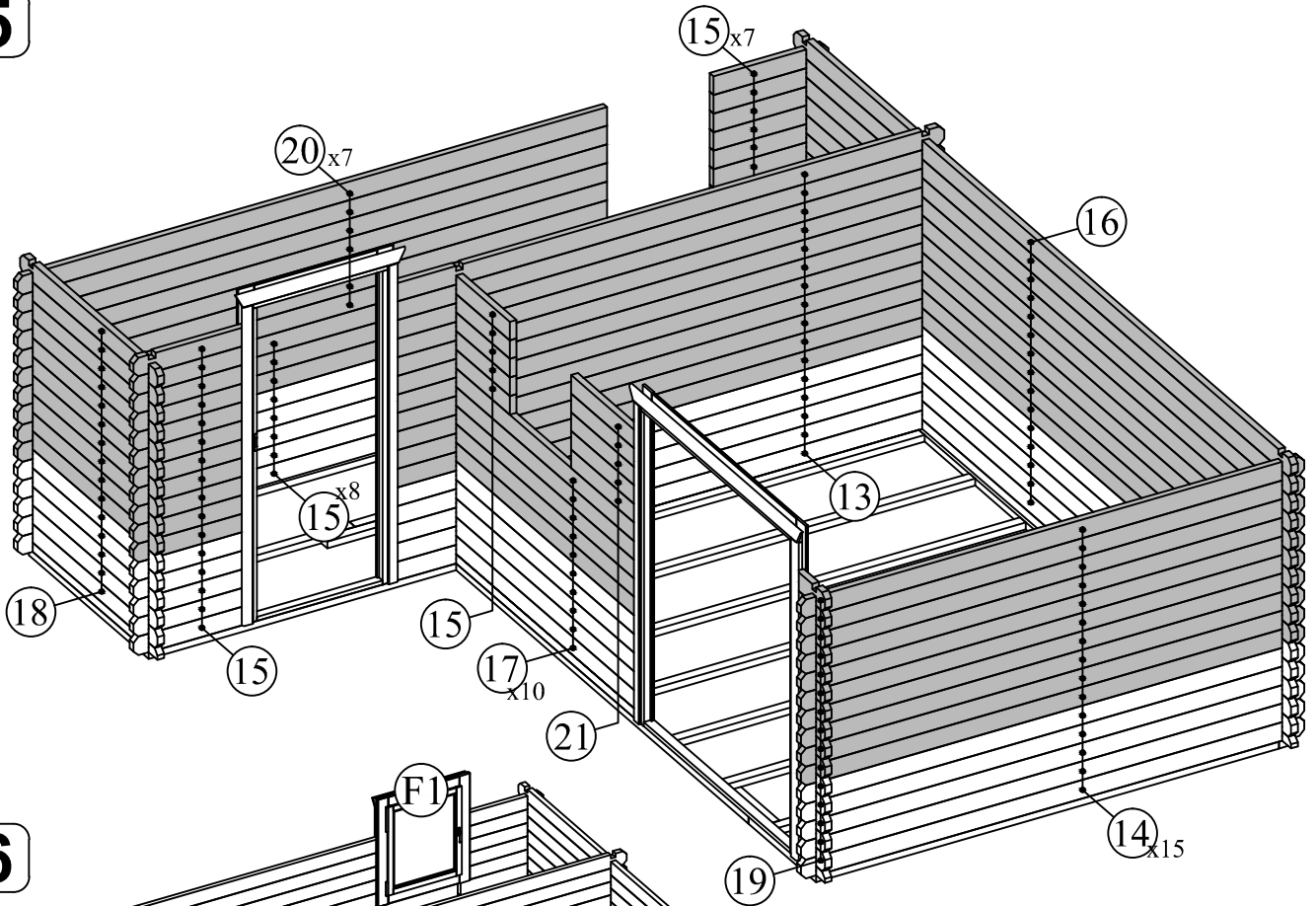

6

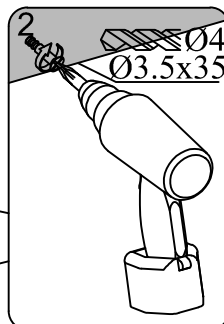
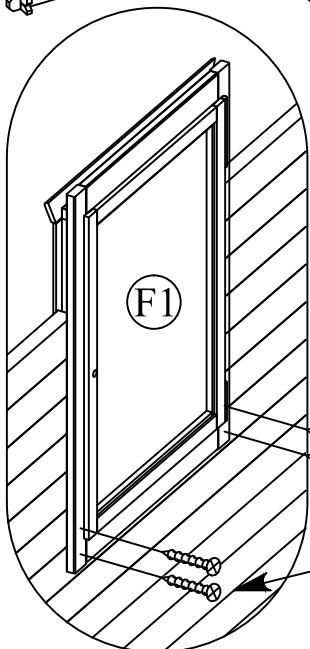
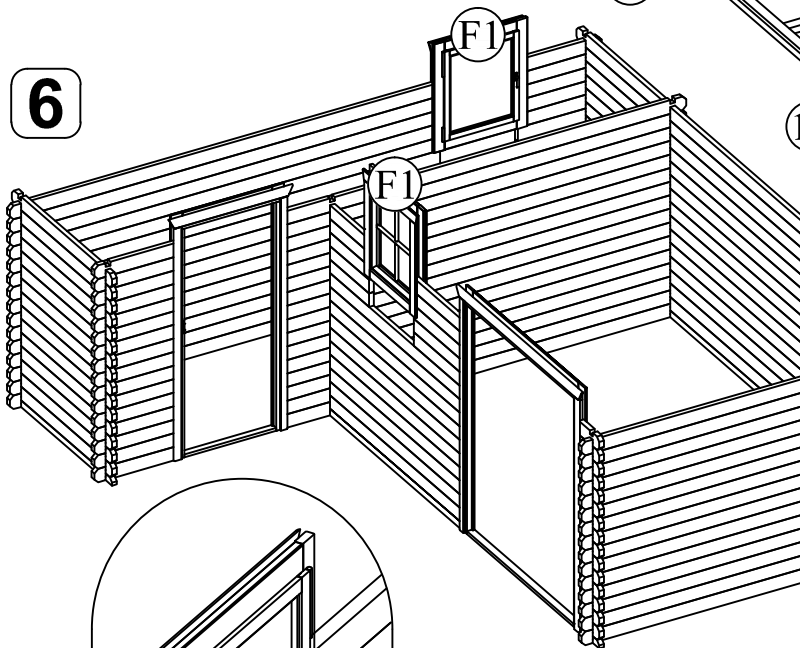

Montage variante
Assembling variant
Des option de montage

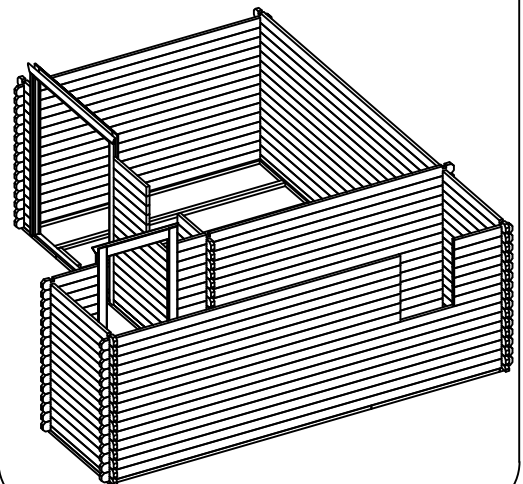

→||←40mm

5,1 x 4,8/2,98

40005

7

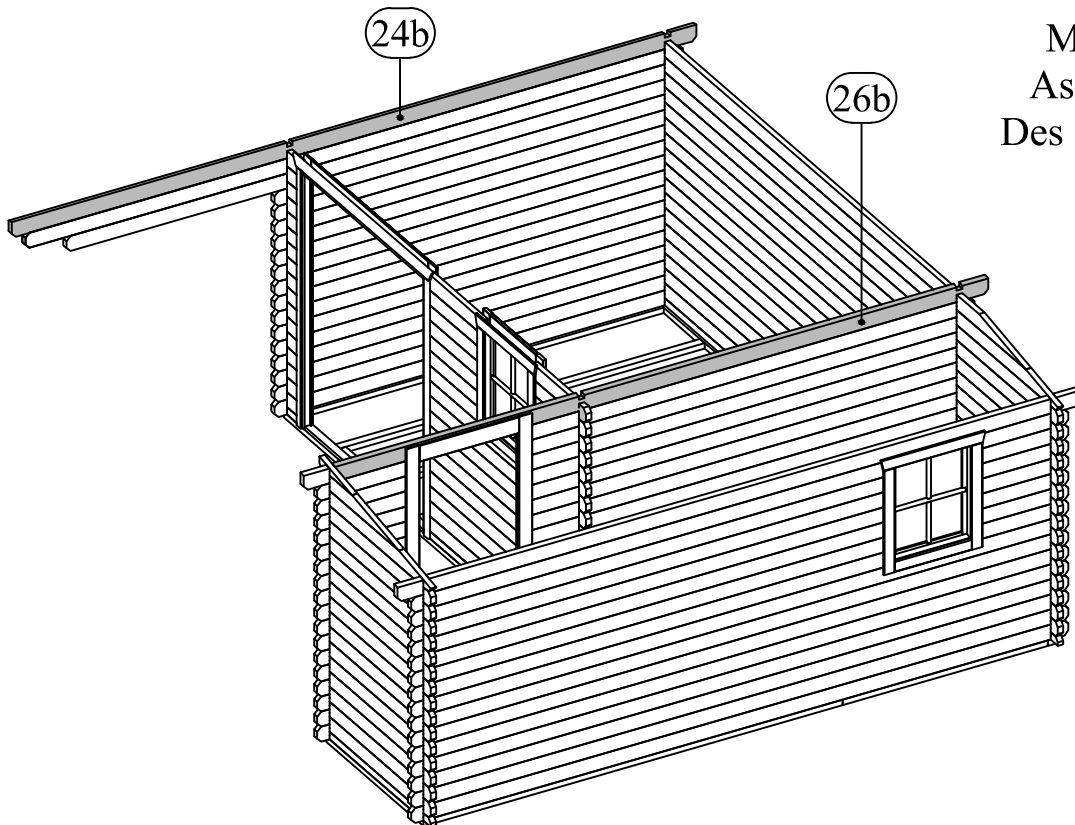
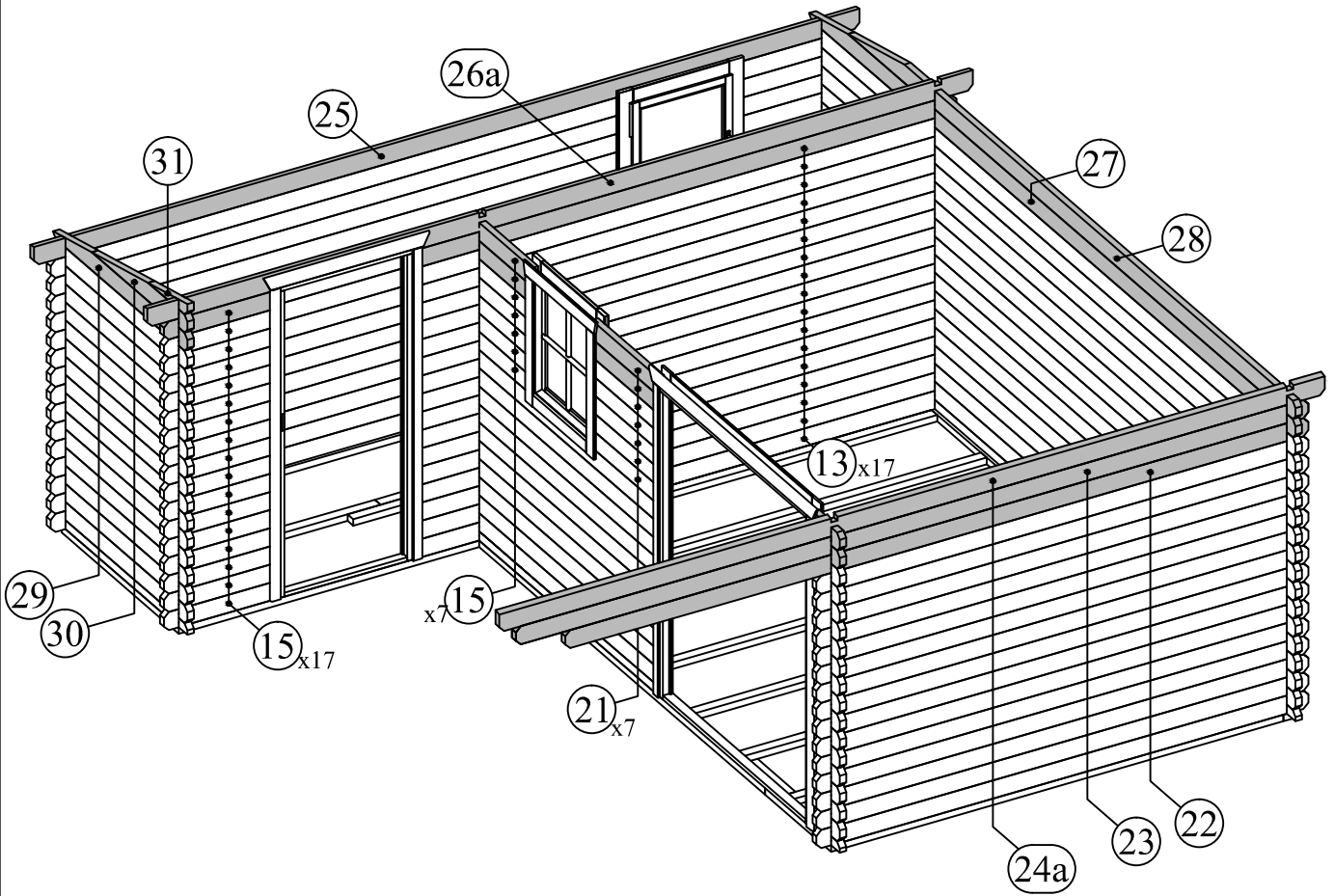

Montage variante
Assembling variant
Des option de montage

→||←40mm

5,1 x 4,8/2,98

40005

8

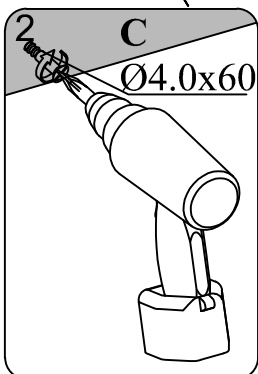
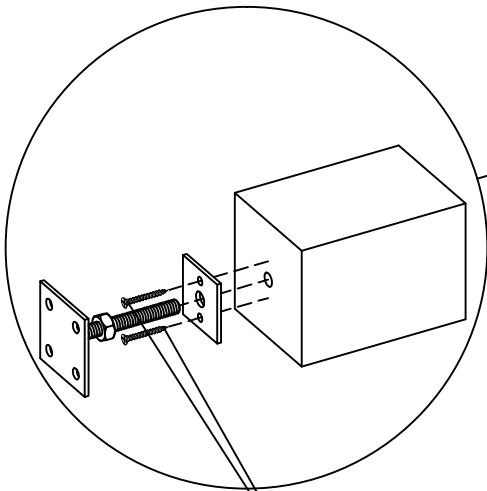
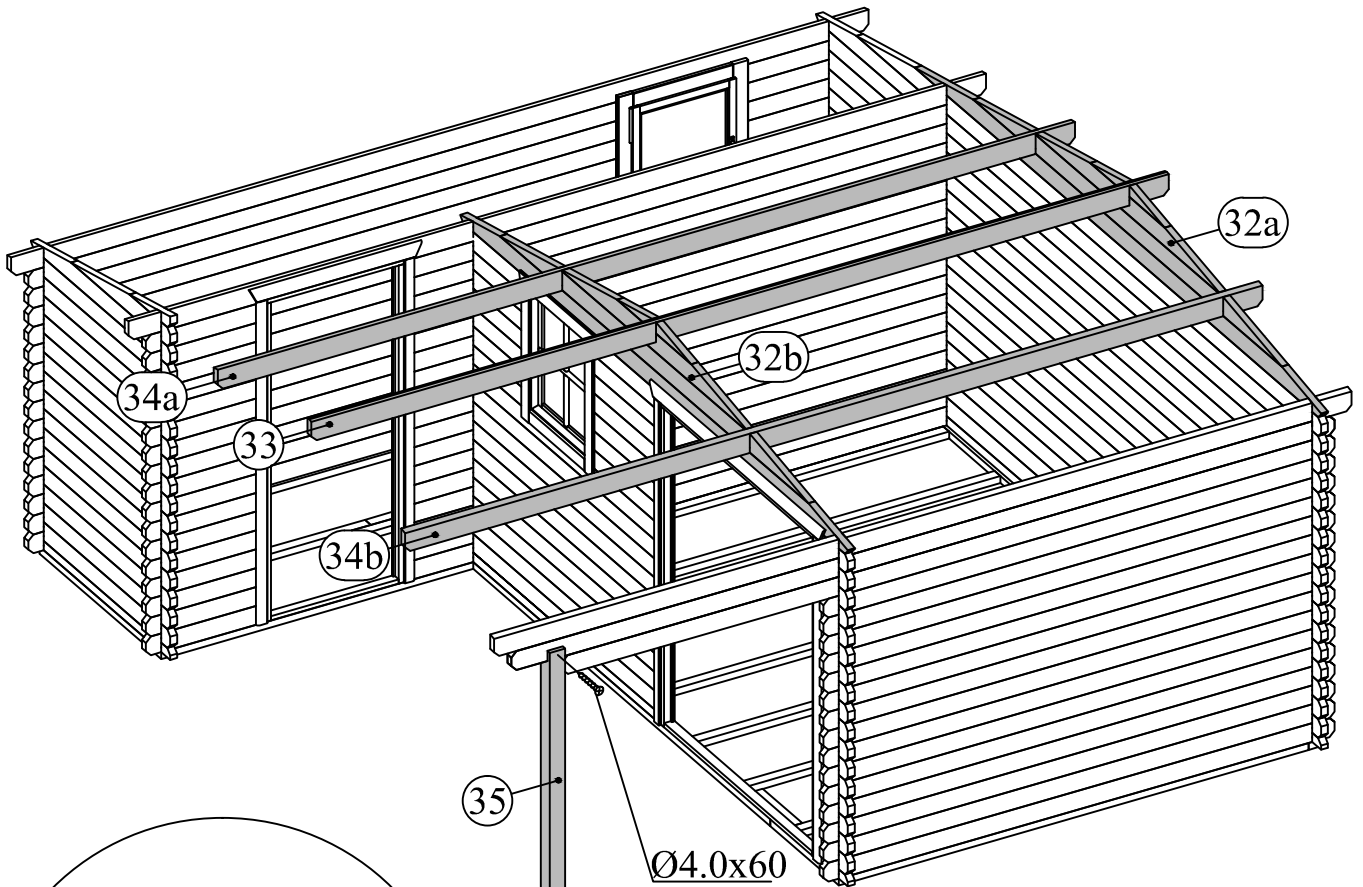

Montage variante
Assembling variant
Des option de montage

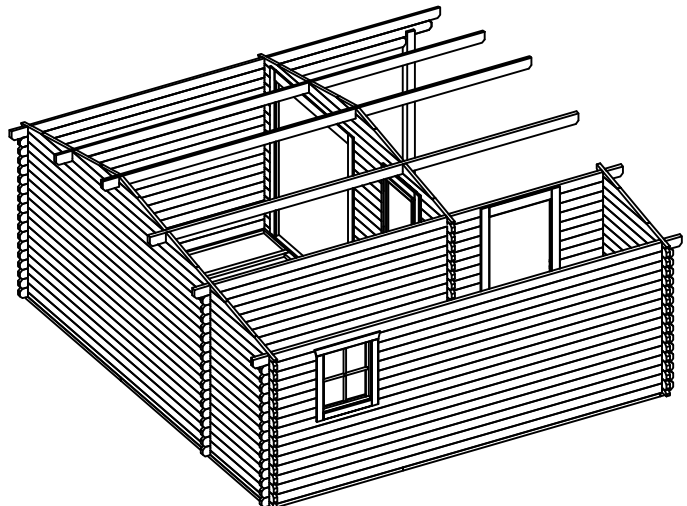

→||←40mm

5,1 x 4,8/2,98

40005

9

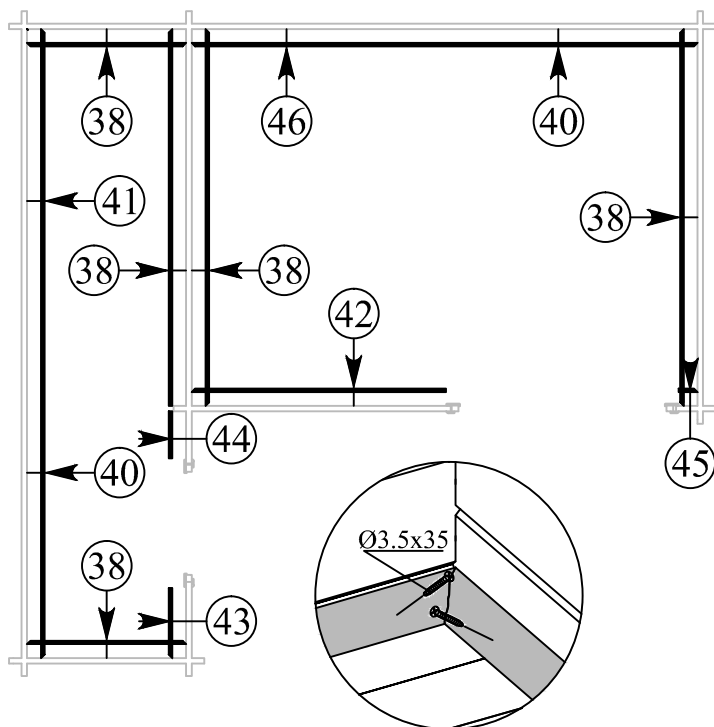
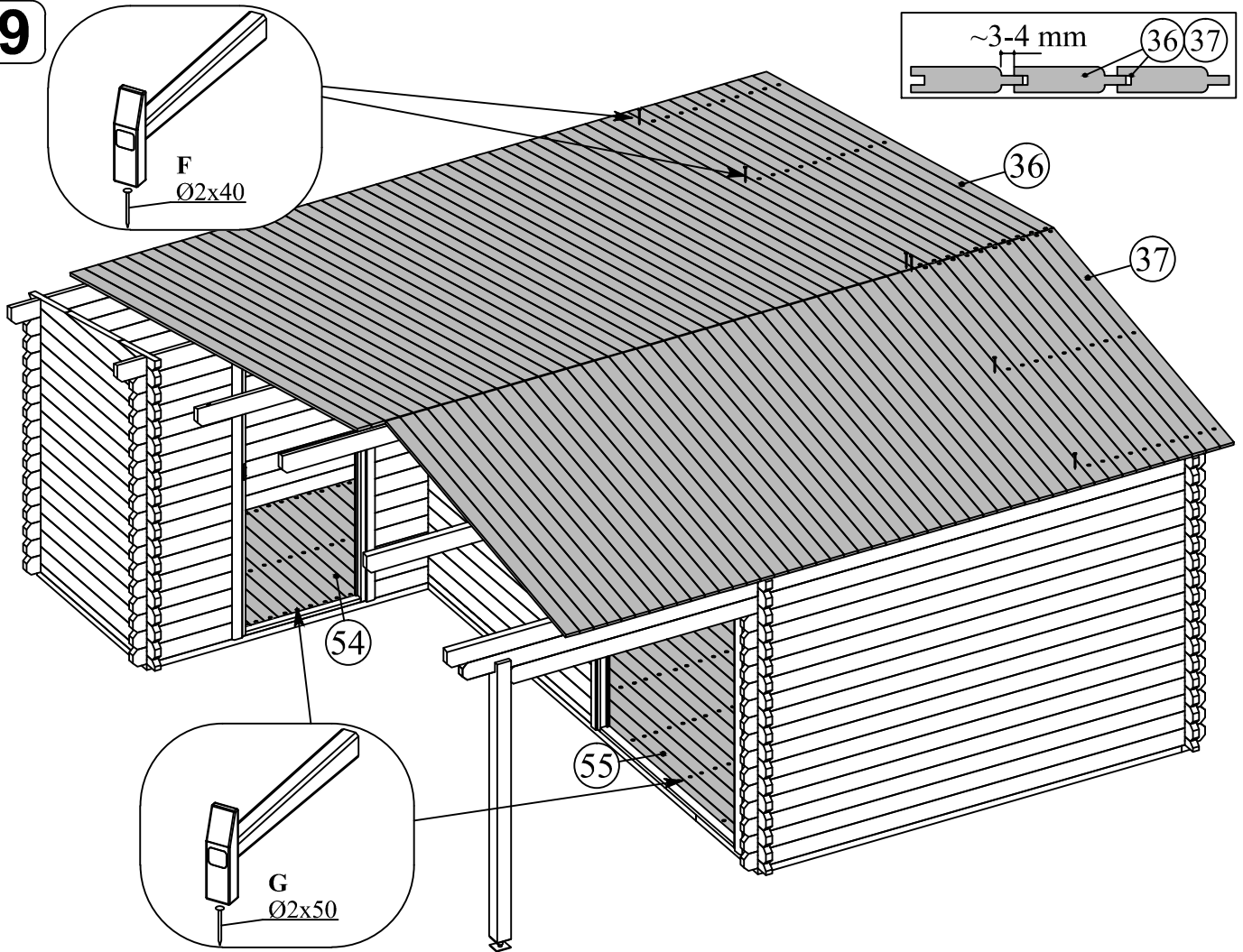

Montage variante
Assembling variant
Des option de montage

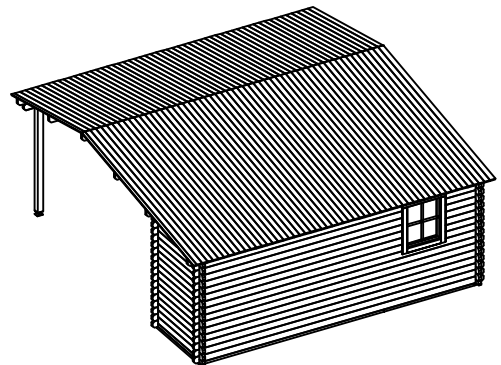

→||←40mm

5,1 x 4,8/2,98

40005

10

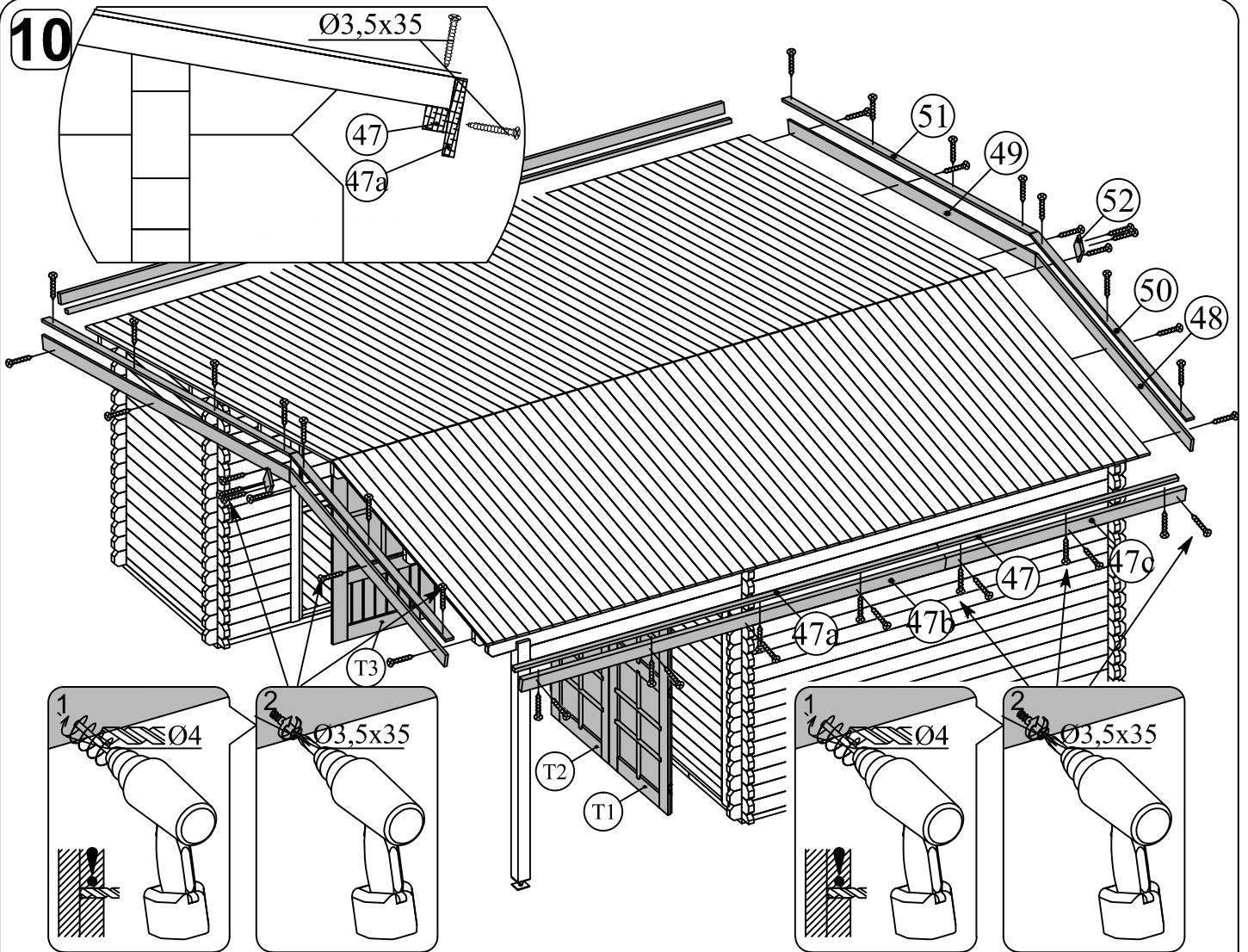

11

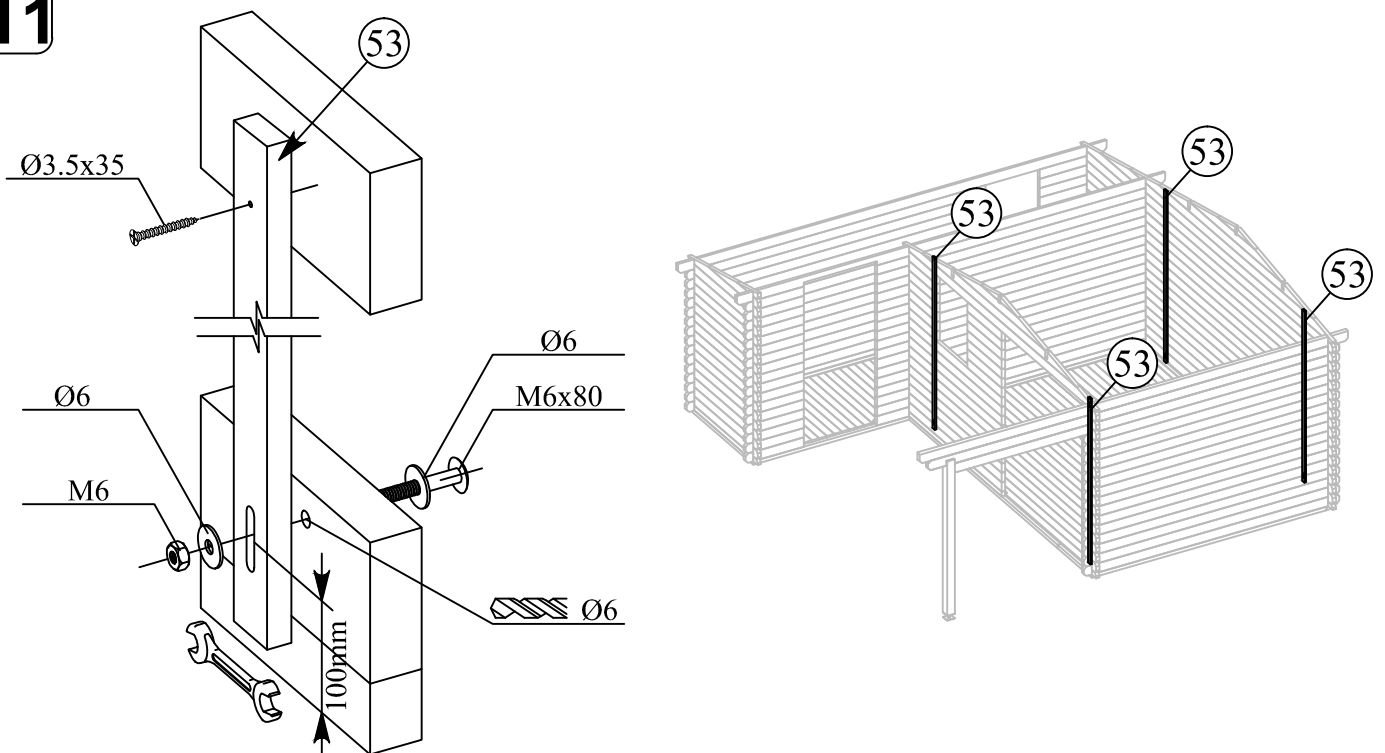

→||←40mm

5,1 x 4,8/2,98

40005

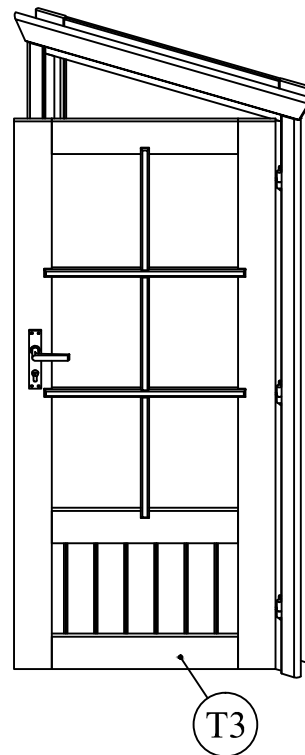
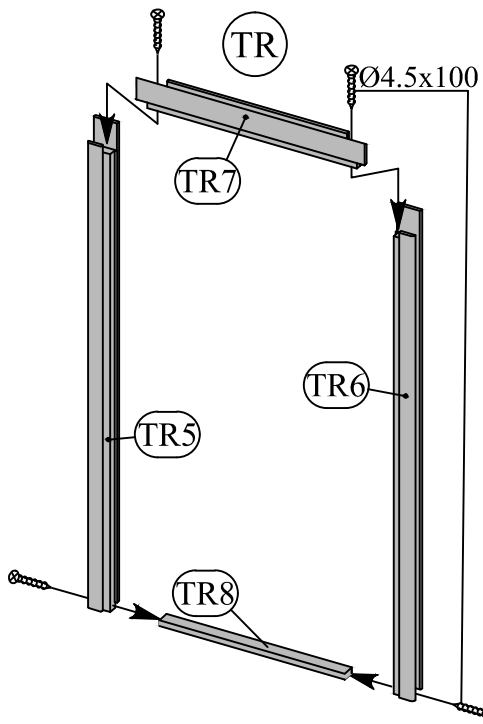
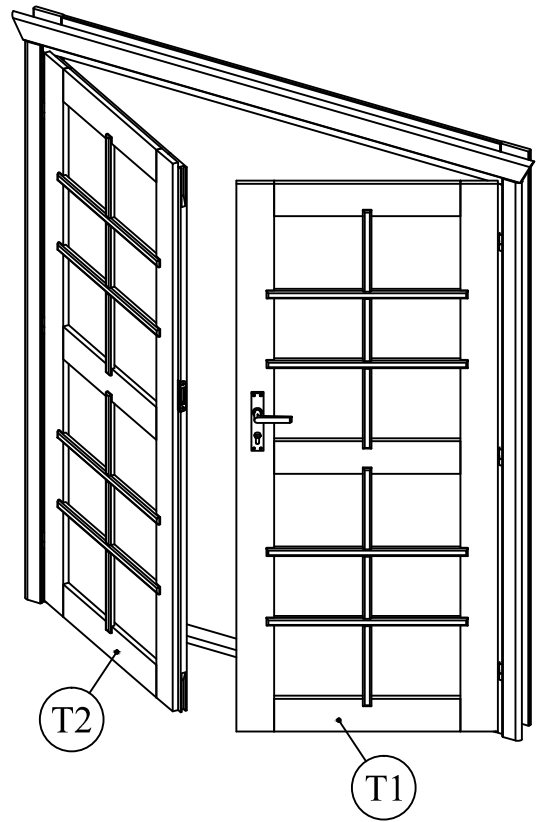
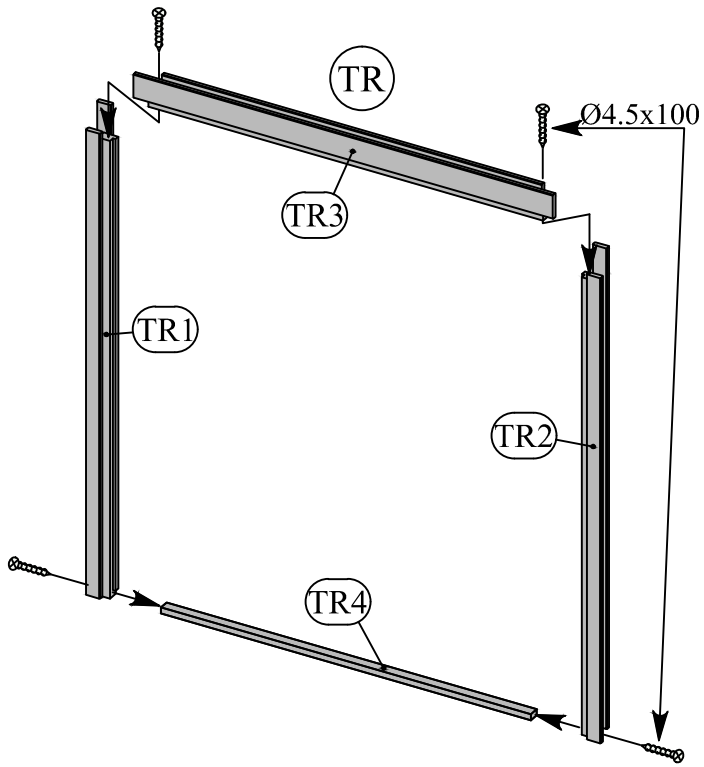

→||←40mm

5,1 x 4,8/2,98

40005

