

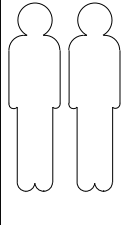











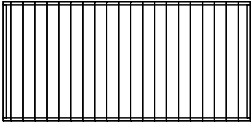
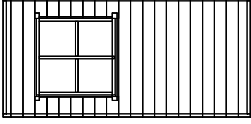
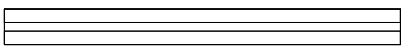
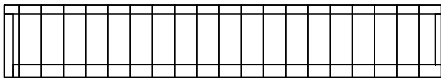
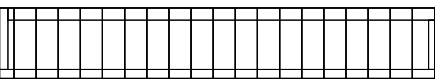
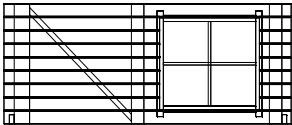
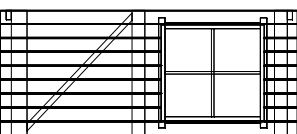
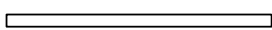

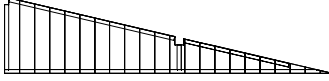
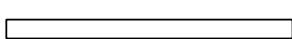
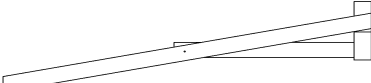
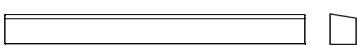
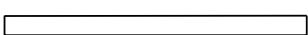

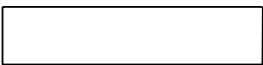
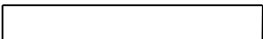
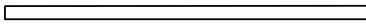

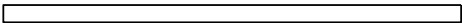
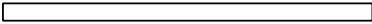
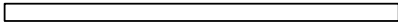
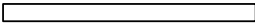
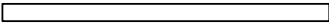
- (A) 4x45 x 101
- (B) 3x25 x 300
- (C) 1.4x25 x 28
- (D) 3x20 x 20
- (E) 3x13 x 10

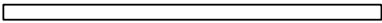
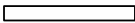
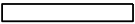

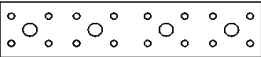
№		PCS	 mm	 mm	 mm
1		7		980	1900
2		1		980	1900
3		1		89	1960
4		1		200	1814
5		1		200	1814
6		1		770	1760
7		1		770	1760
8		1	25	30	1560
9		1		500	2005
10		1		500	2005
11		1	30	60	1560
12		2		510	1960
13		4	40	60	1575
14		2	17	47	1575
15		3	OSB	590	2200
15.1		3	OSB	390	2200
15.2		1	OSB	210	2200

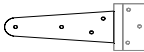
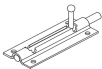
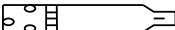
16		2	OSB	35	1575
17		2	13	92	2222
18		5	15	35	2165
19		2	15	35	1835
20		4	17	47	1900
21		2	15	35	855
22		6	15	35	1575
23		3		505	980
24		1	19	35	135
25		3	15	35	1900
26		2	15	35	500
27		2	17	47	495
28		3		1m	2,30m
29		1		0,5m	2,30m
30		4			
31		2			
32		6			
33		6			
34		3			
35		1			
36		2			

1

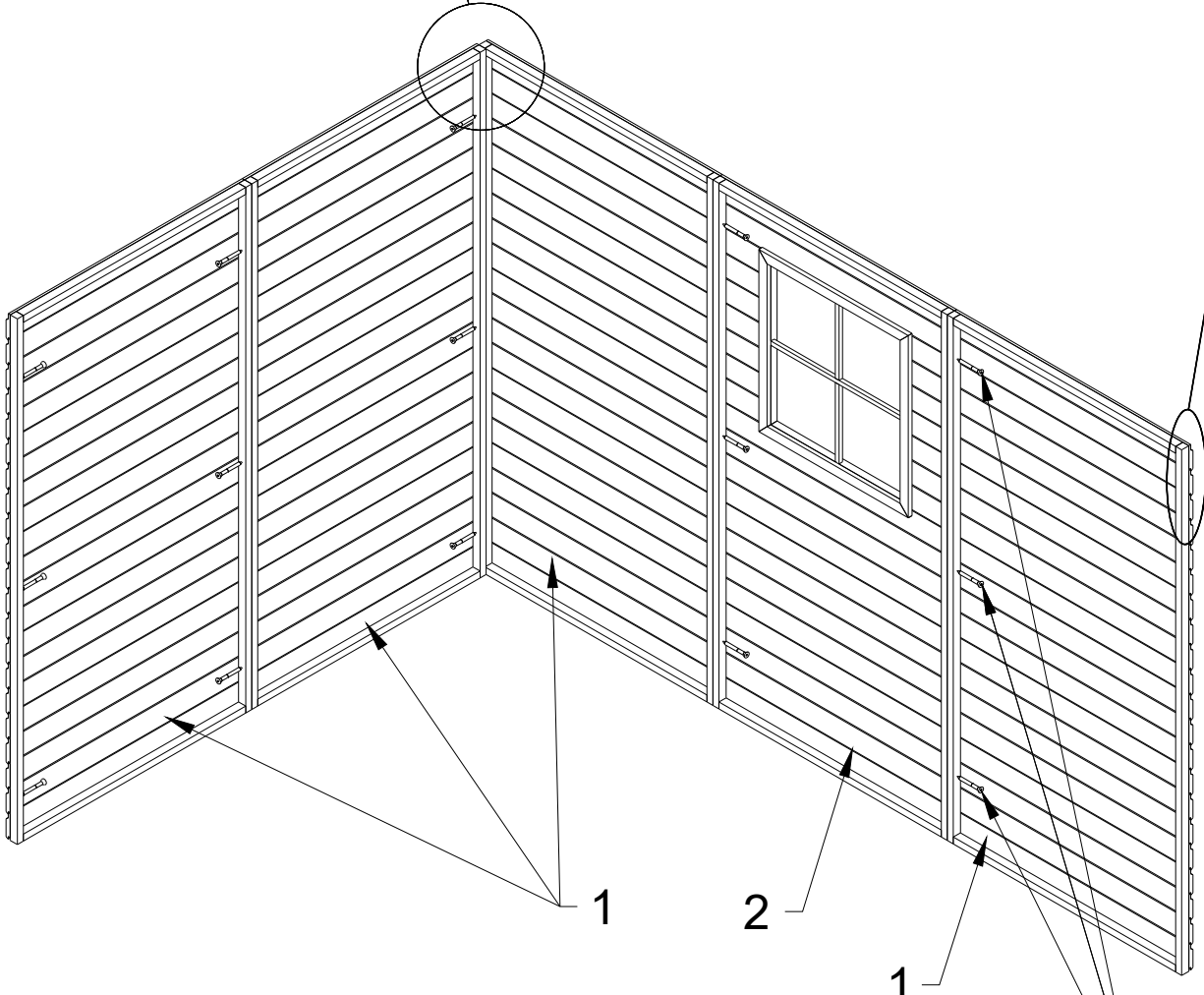
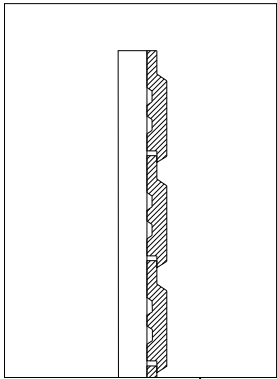
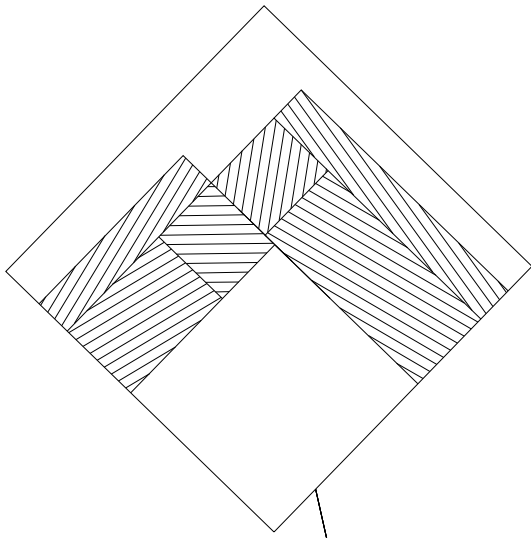

205,6cm

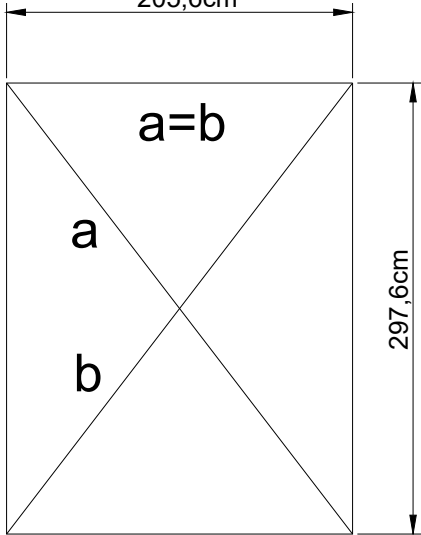

A x15

2

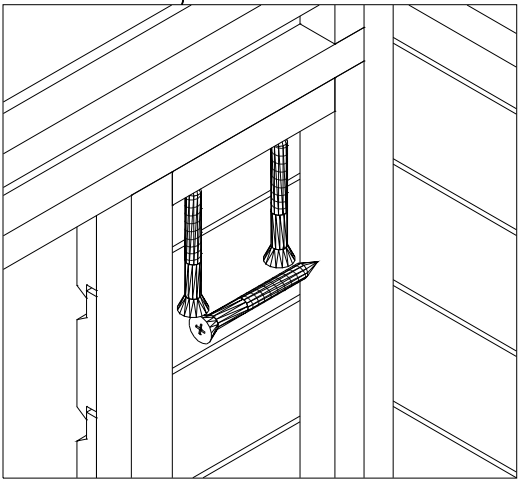
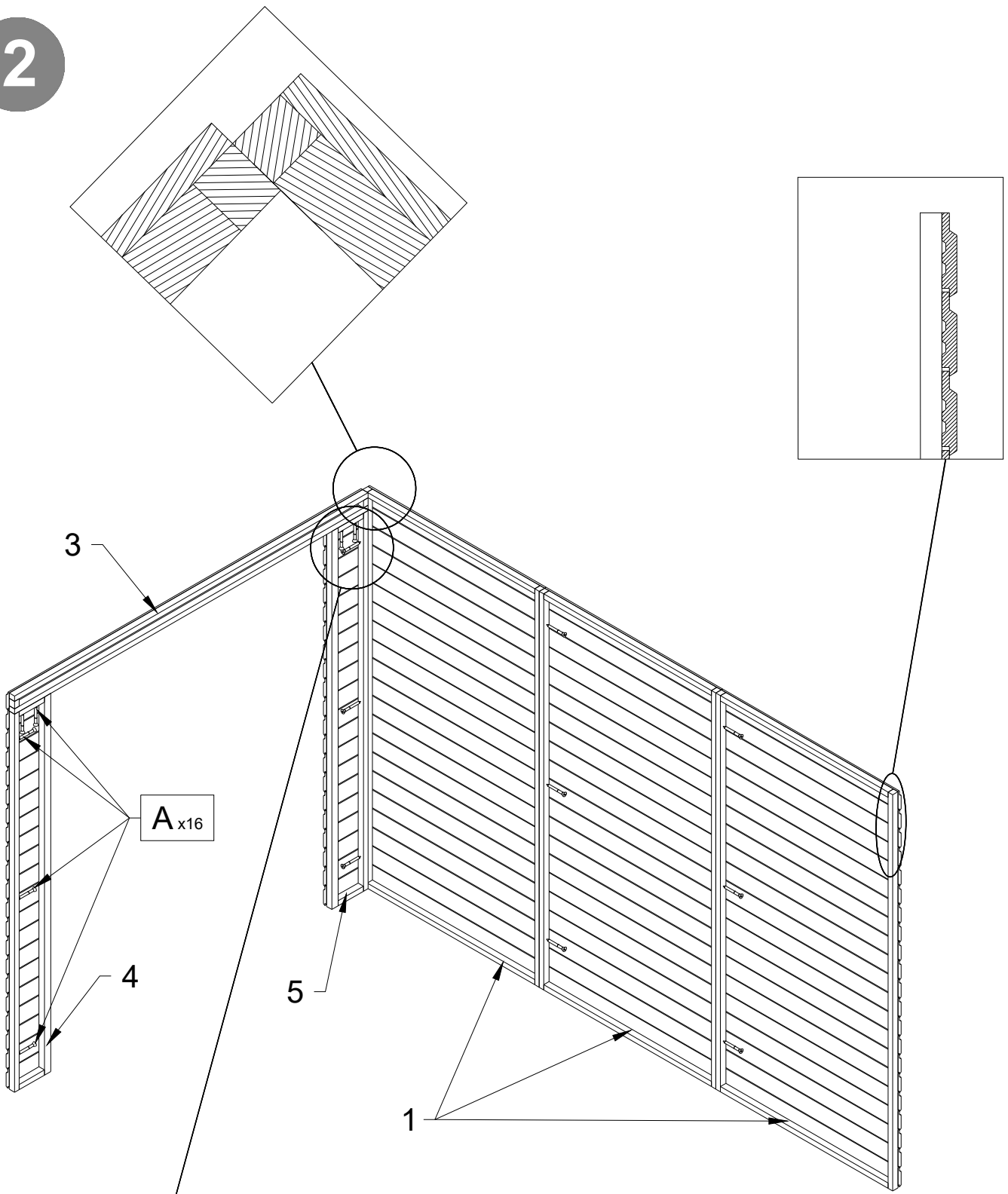

3

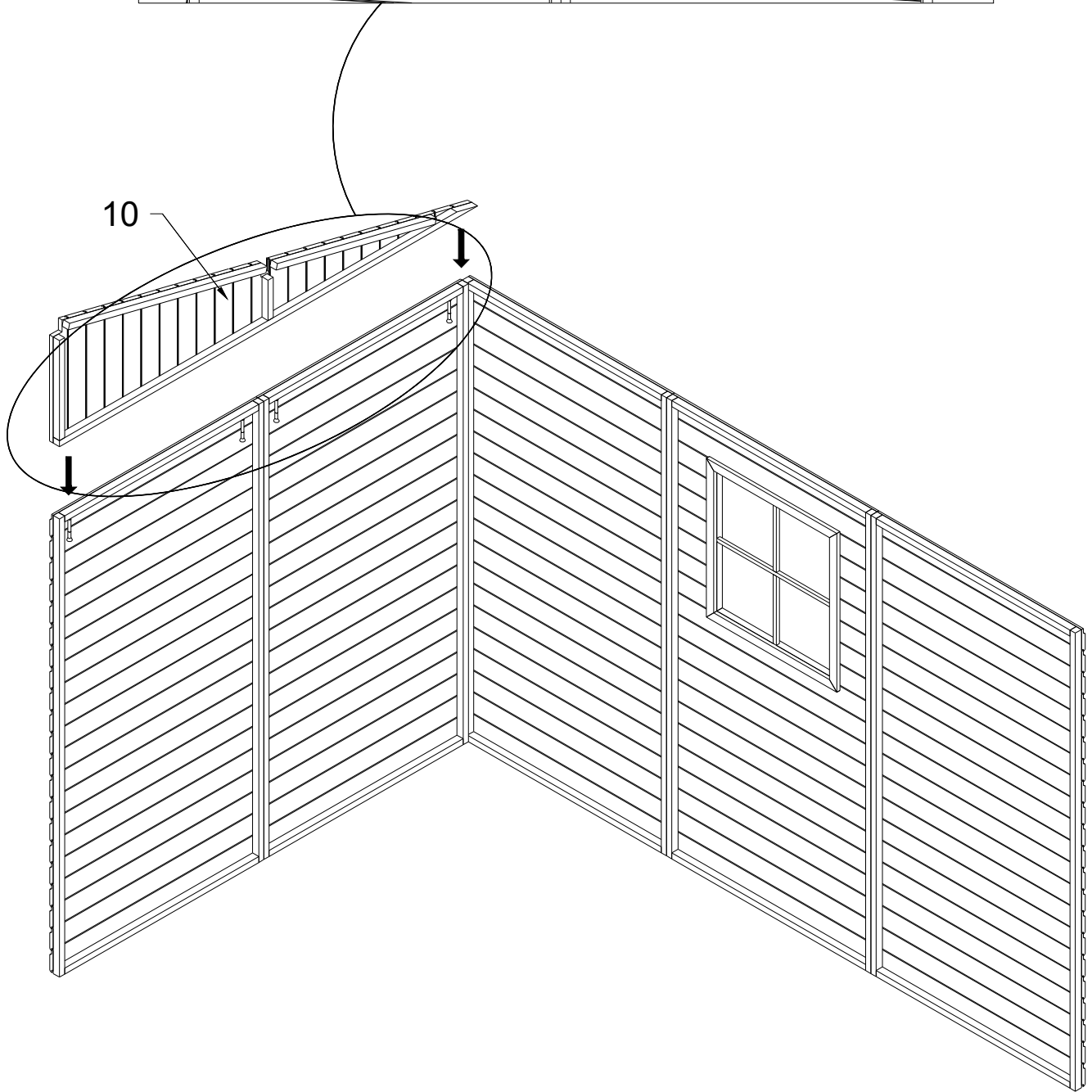
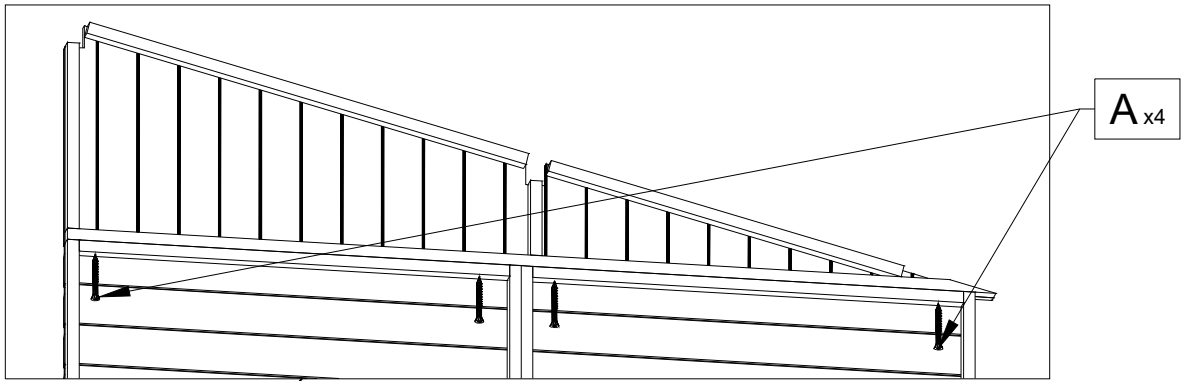

4

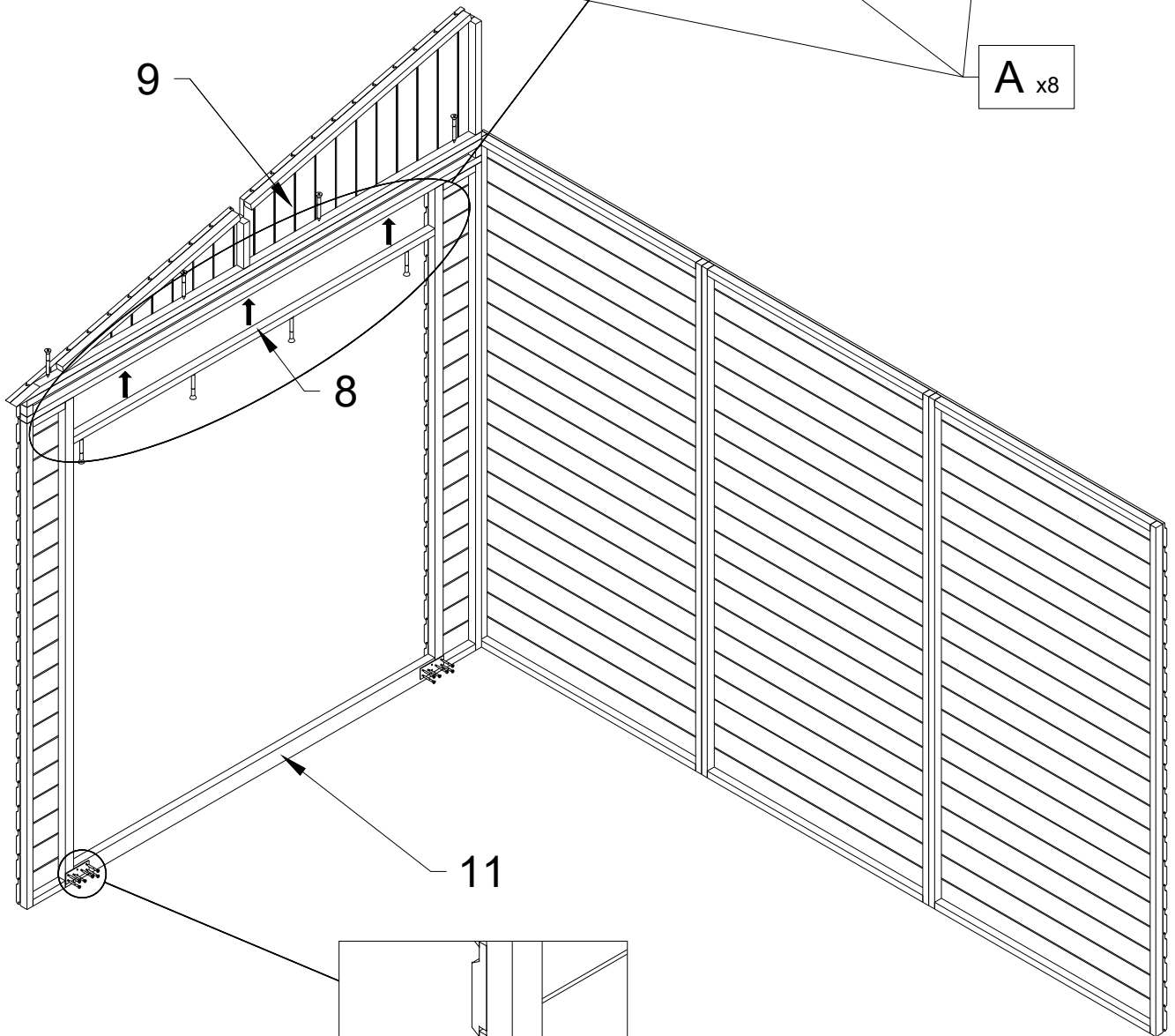
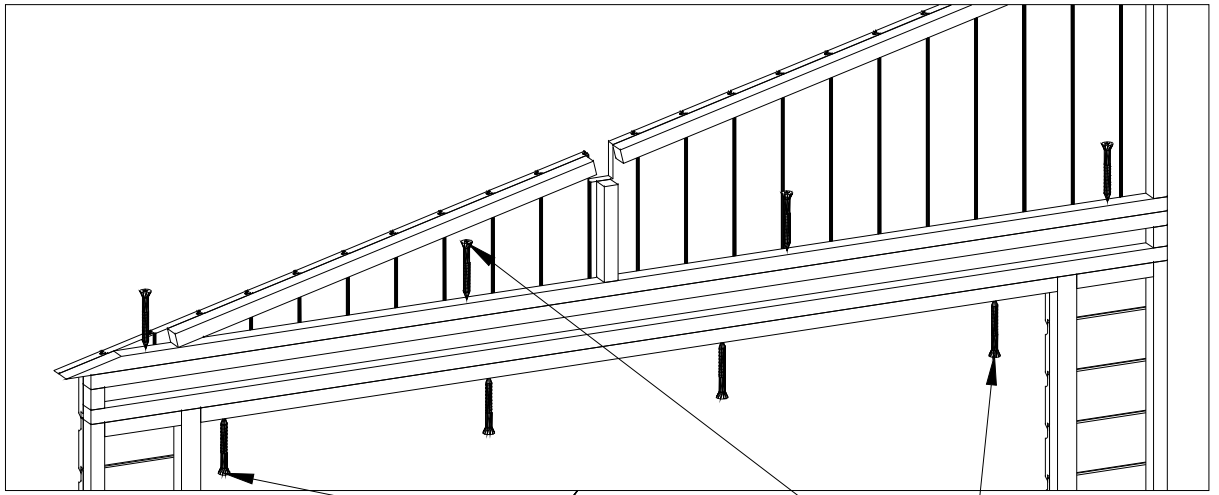

A x8

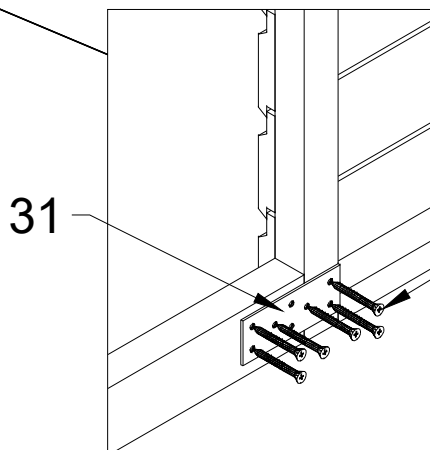

31

B x12

5

A x14

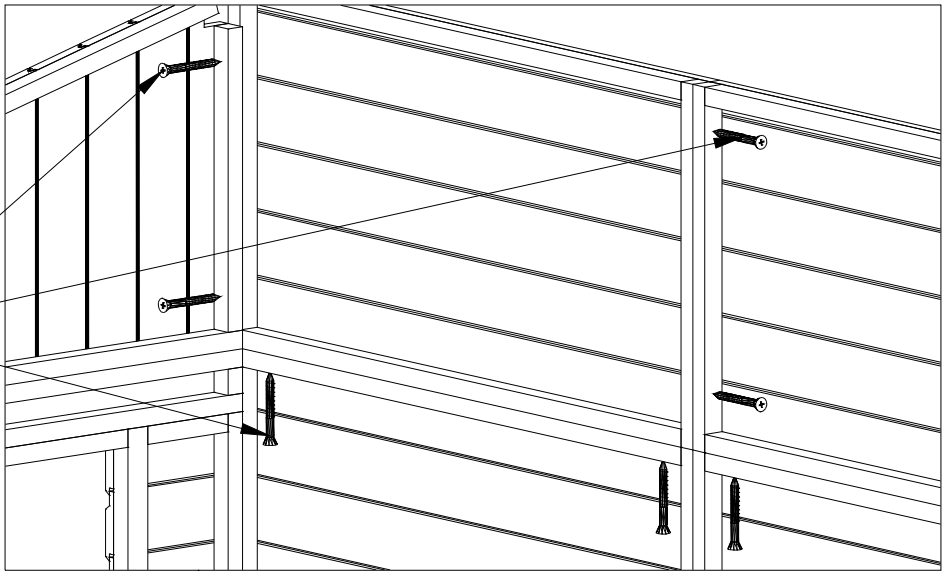

23

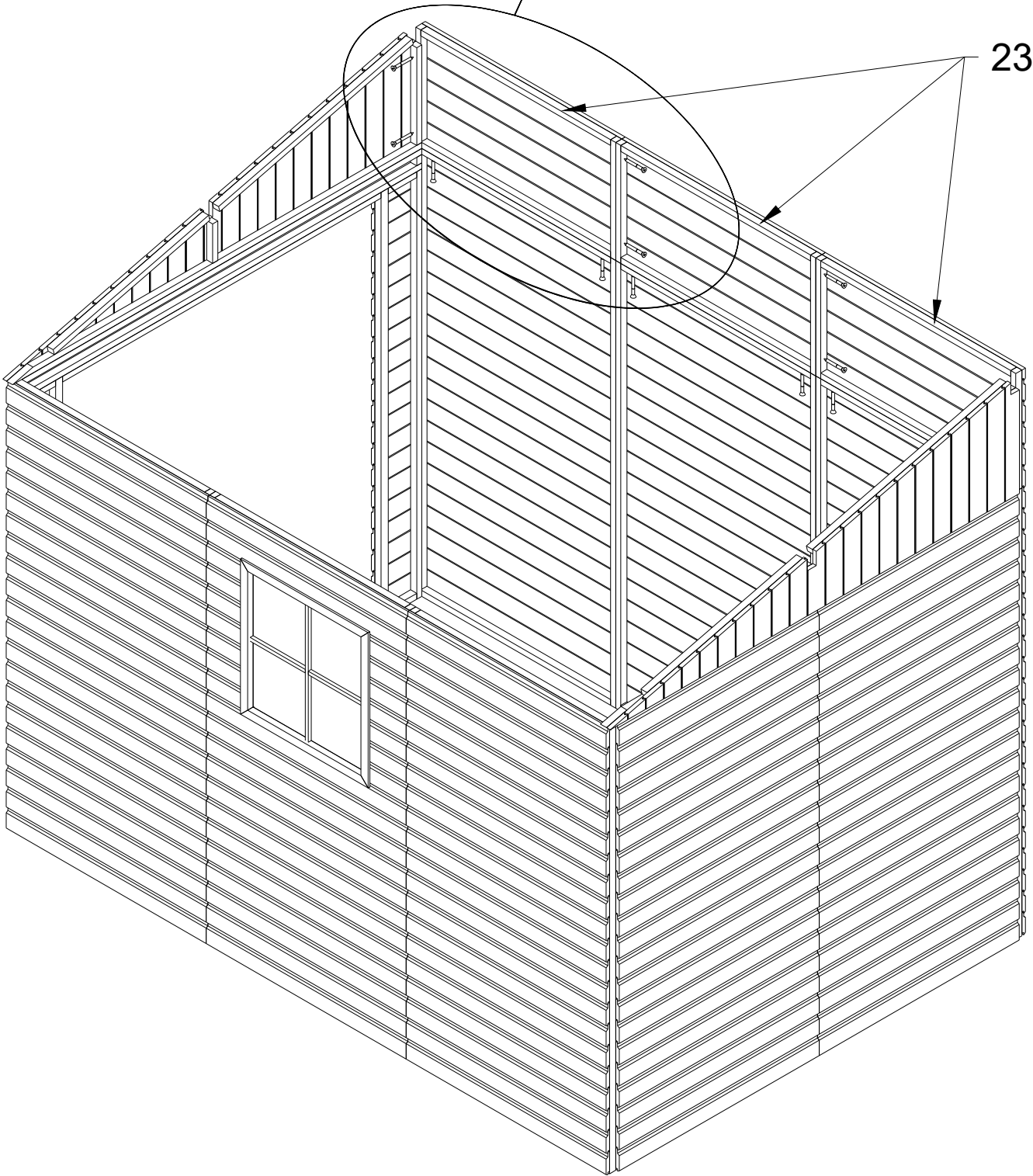

6

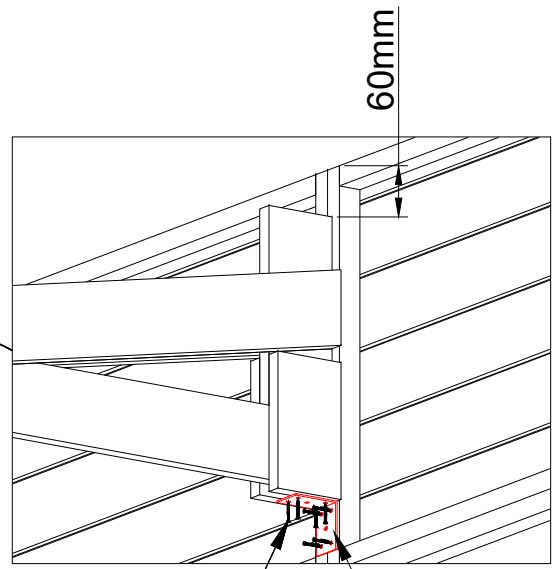
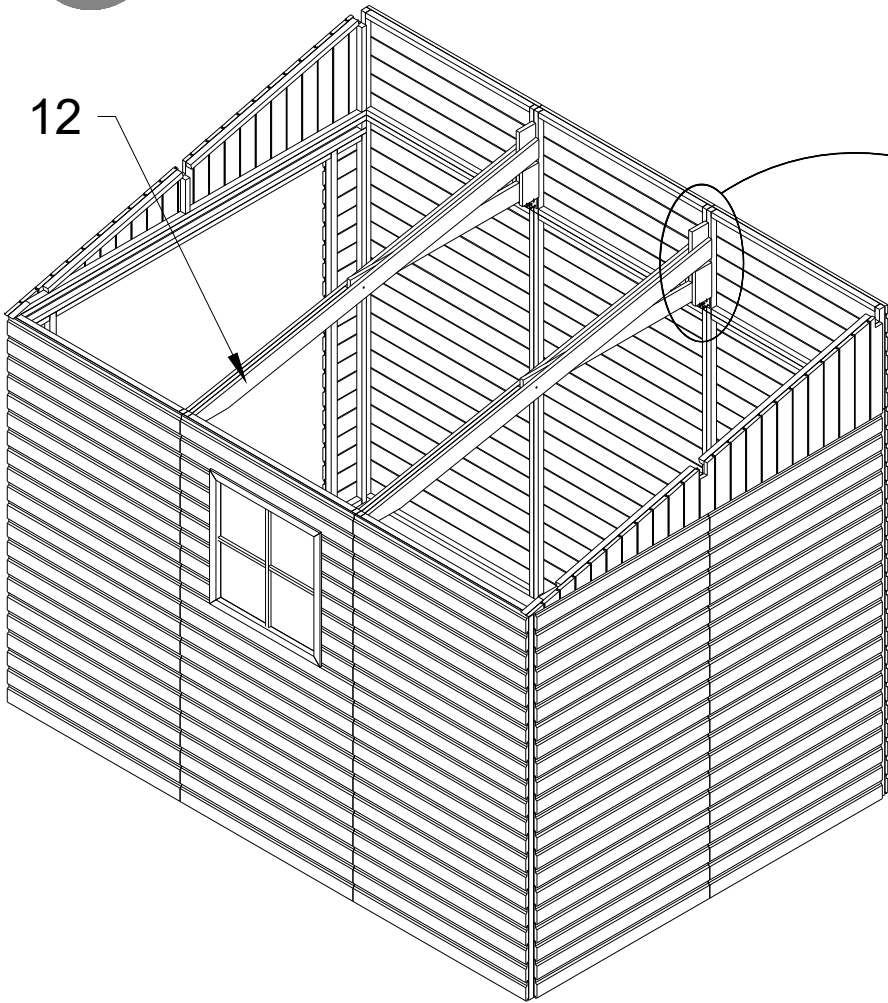

B x16

36

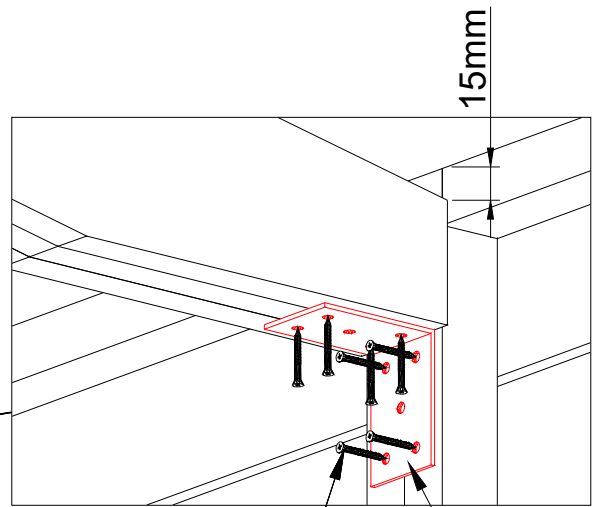
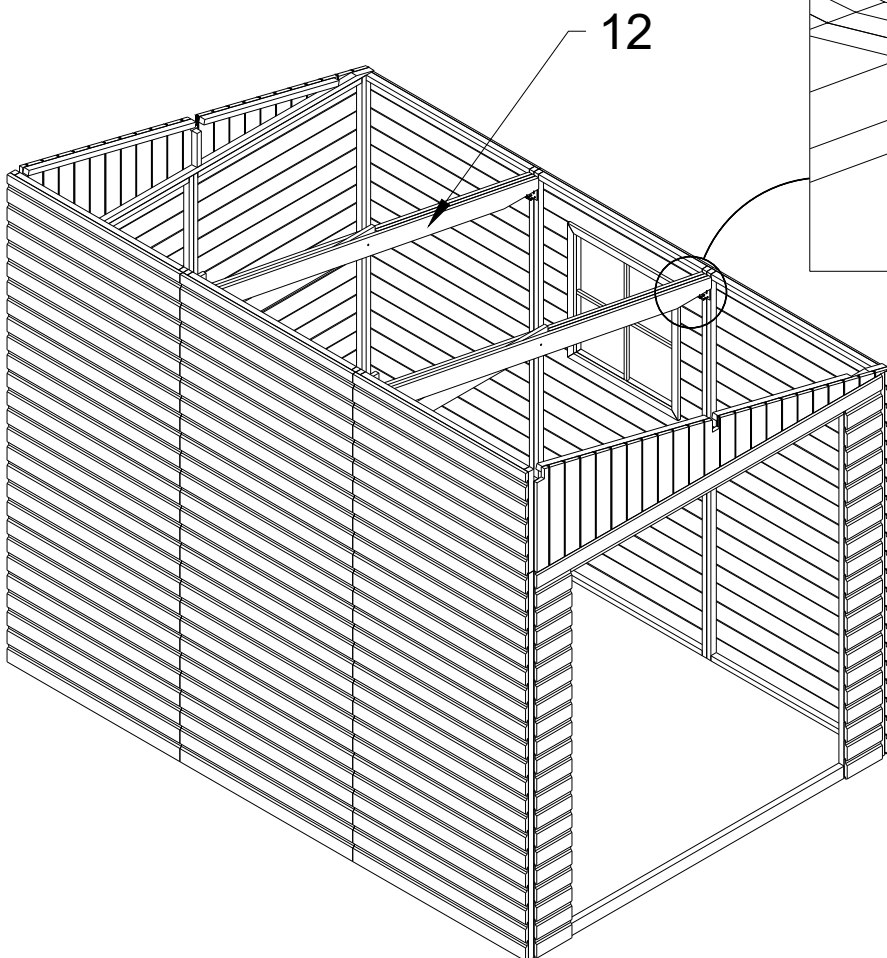

B x16

32

7

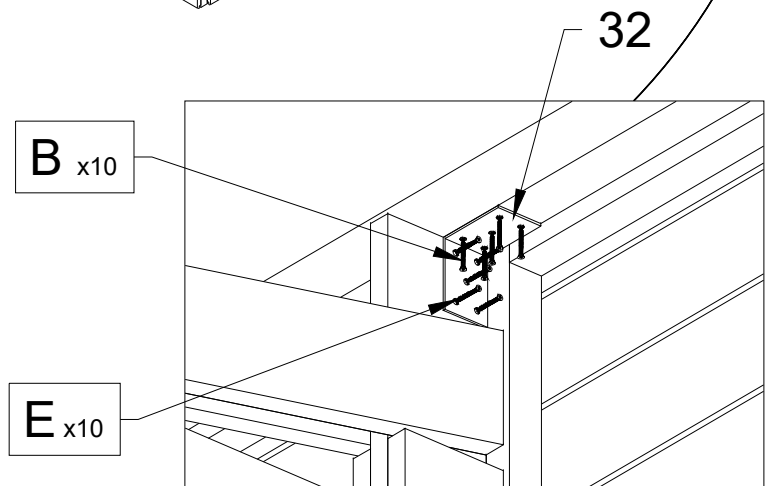
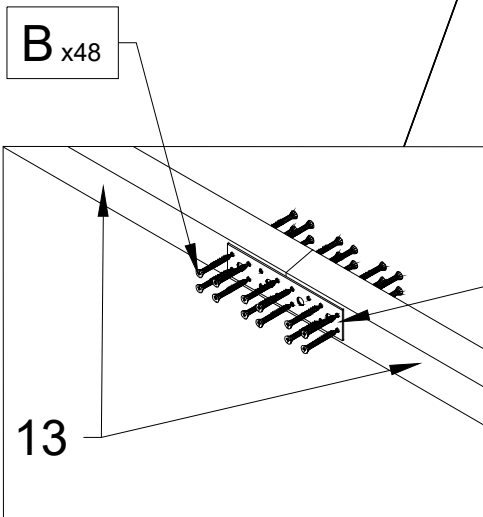
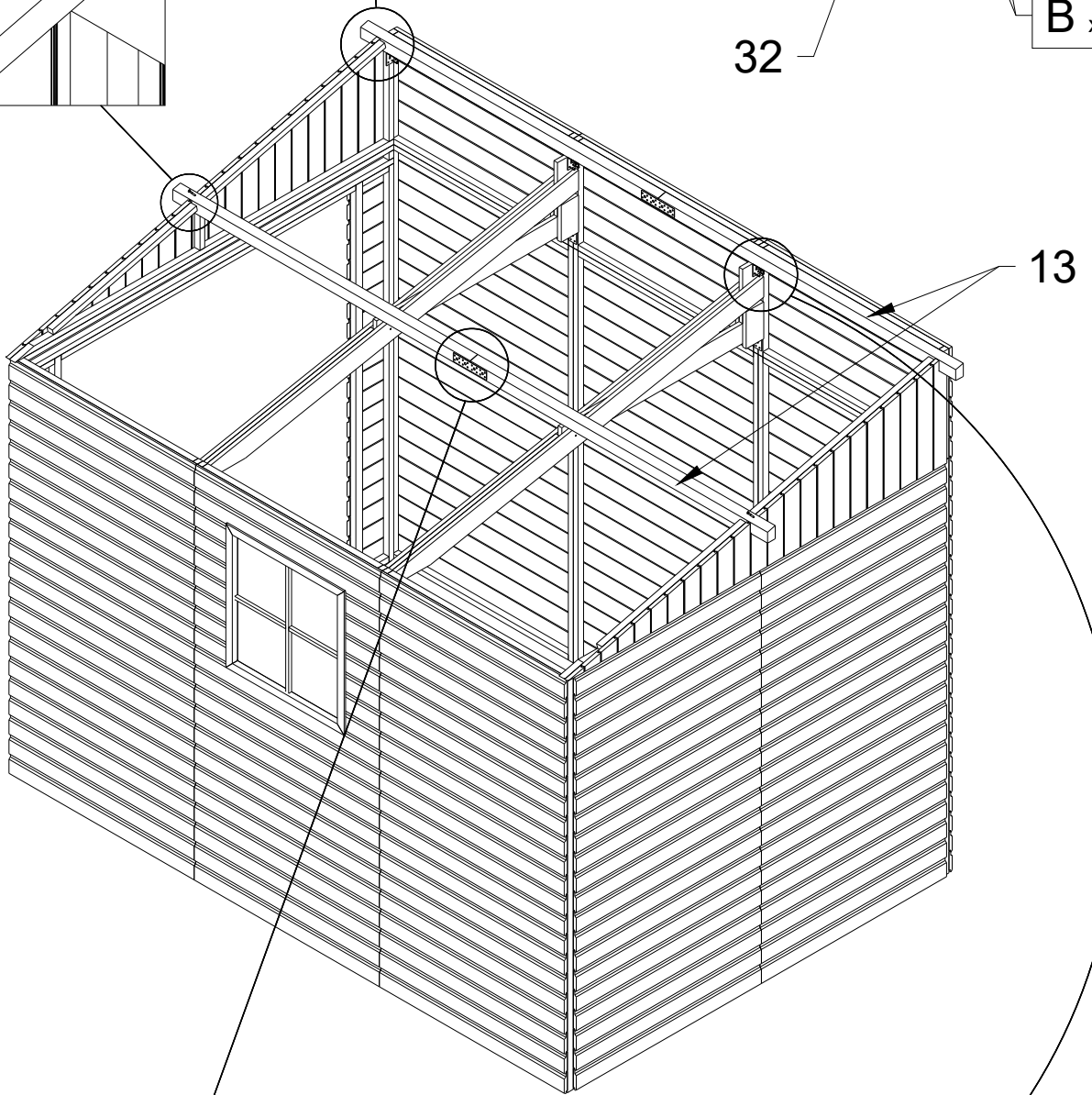
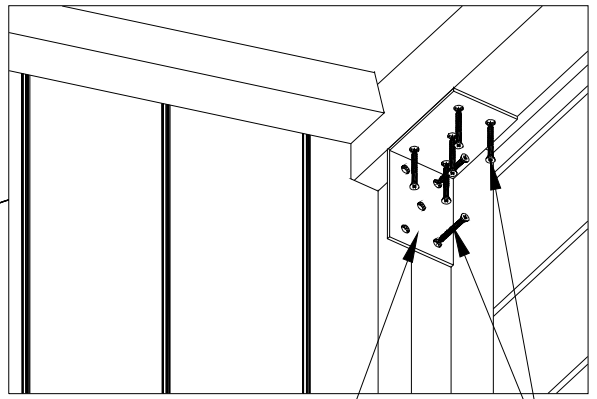
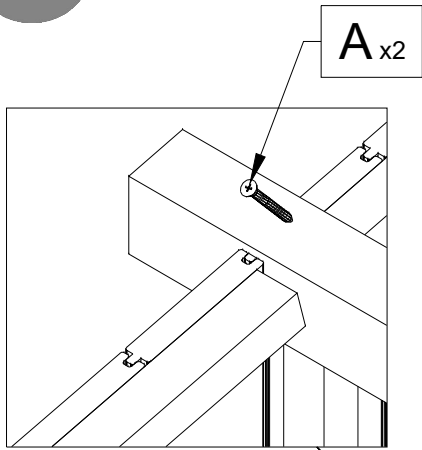

8

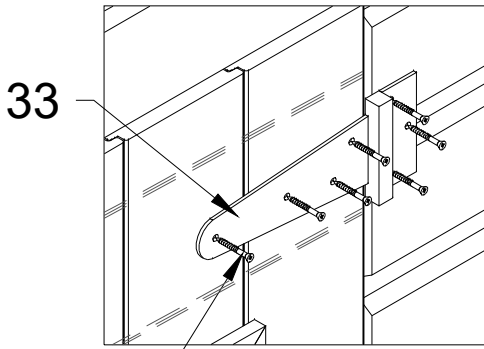

B x42

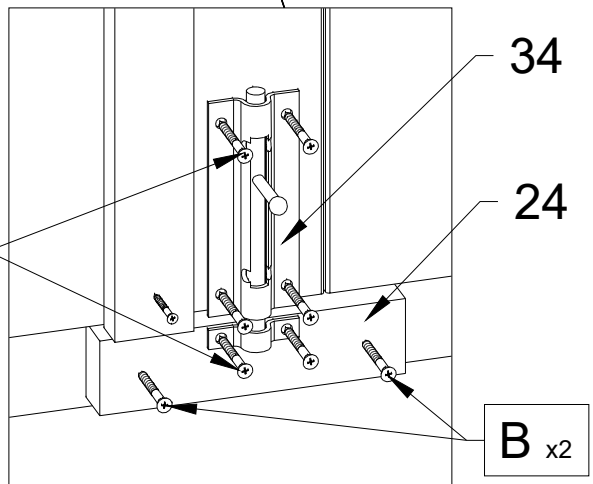
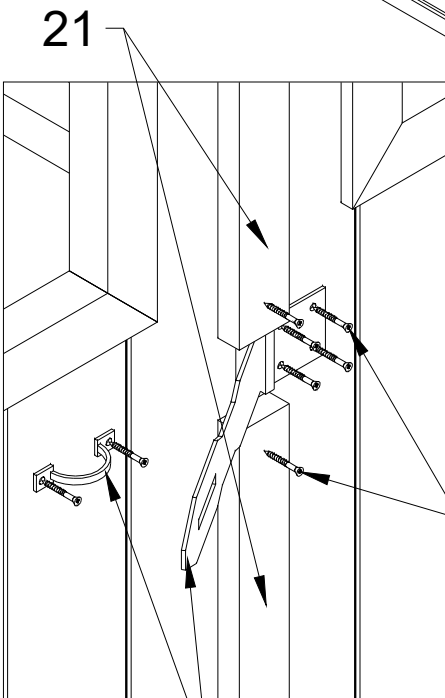
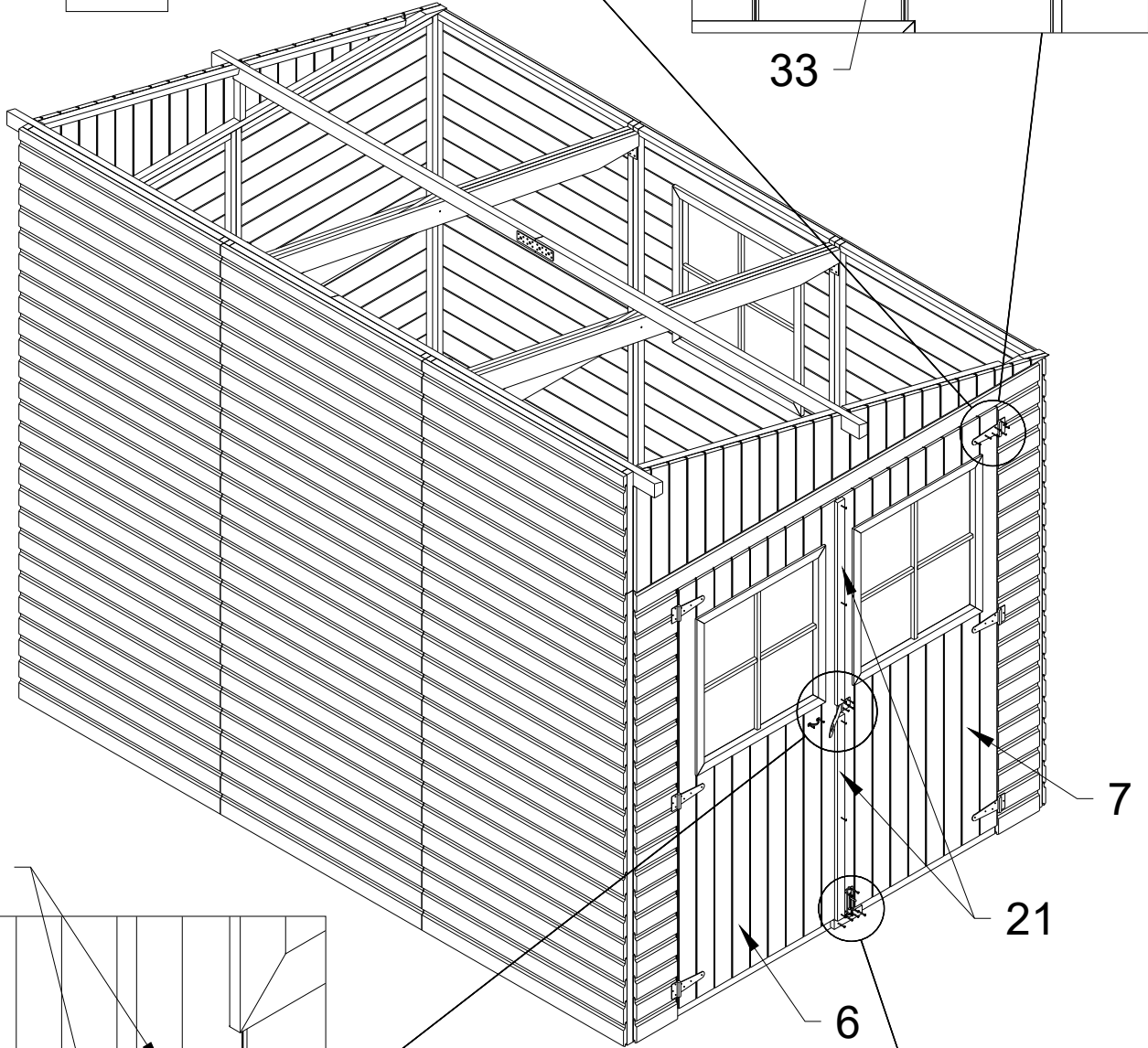
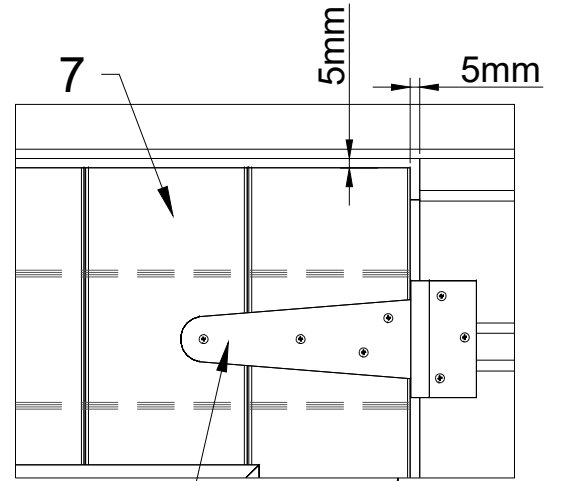

9

B x8

34

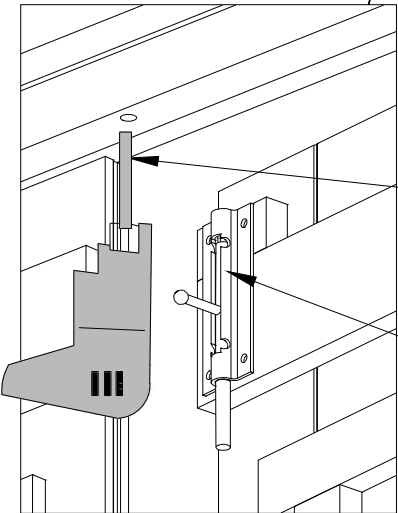
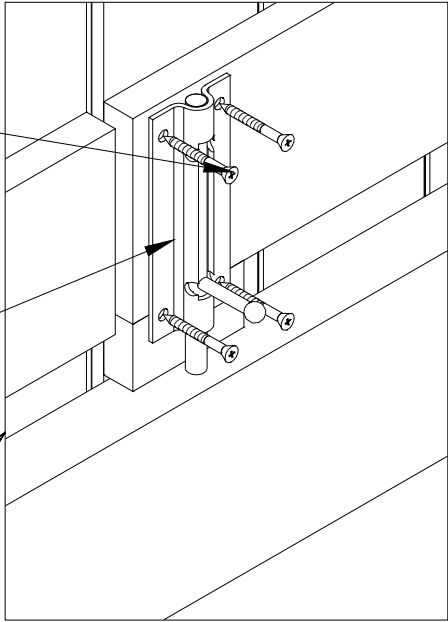
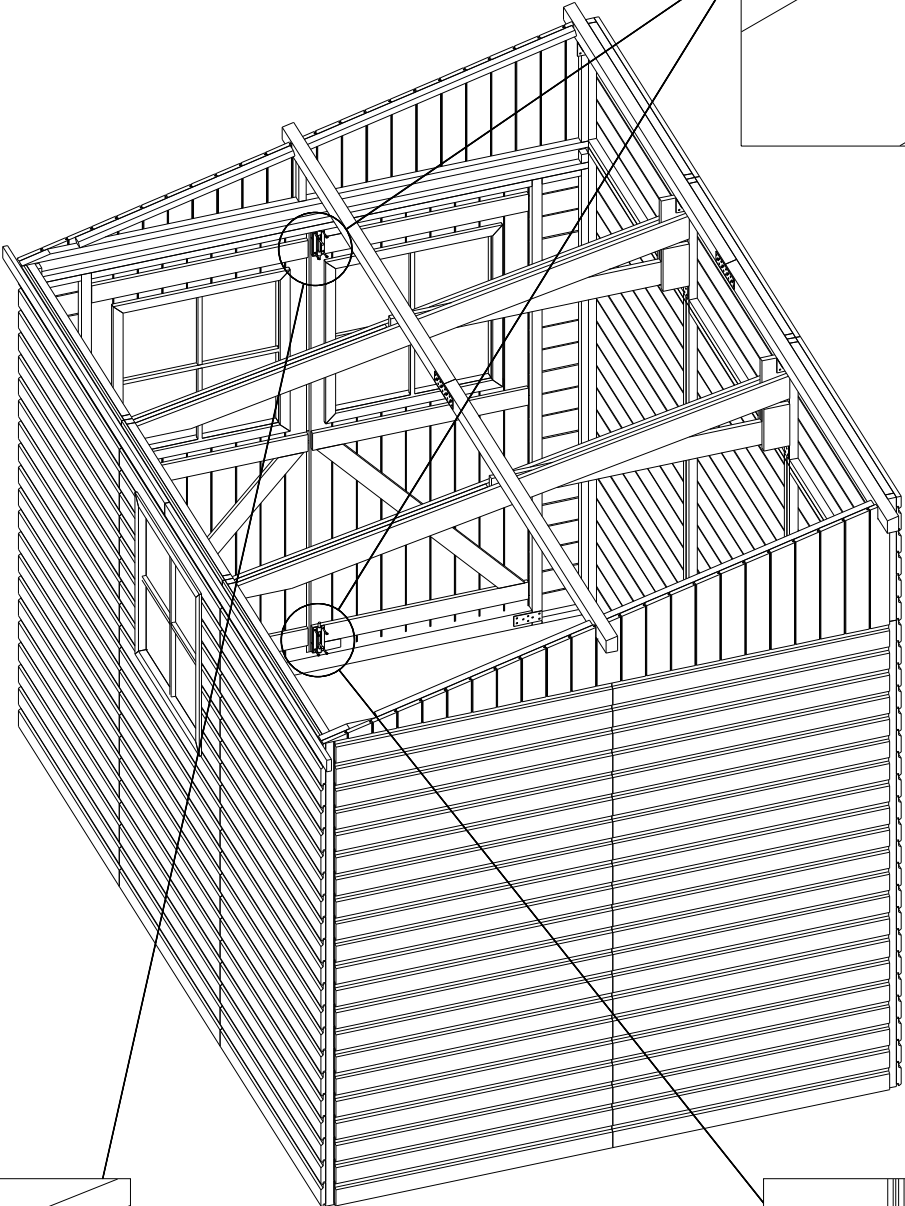

Ø12mm

34

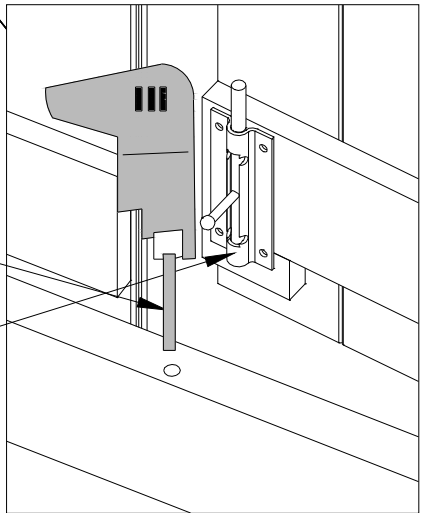

10

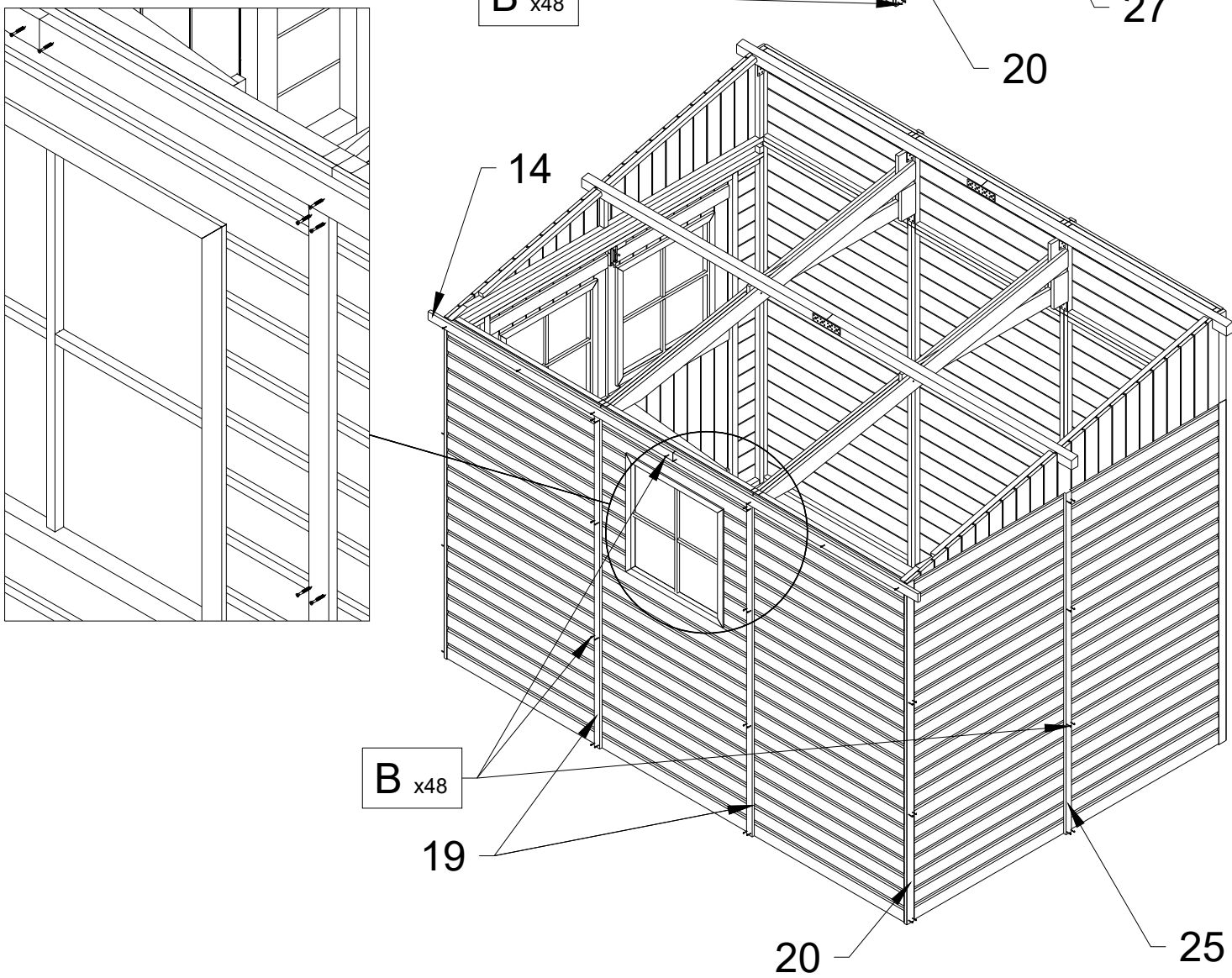
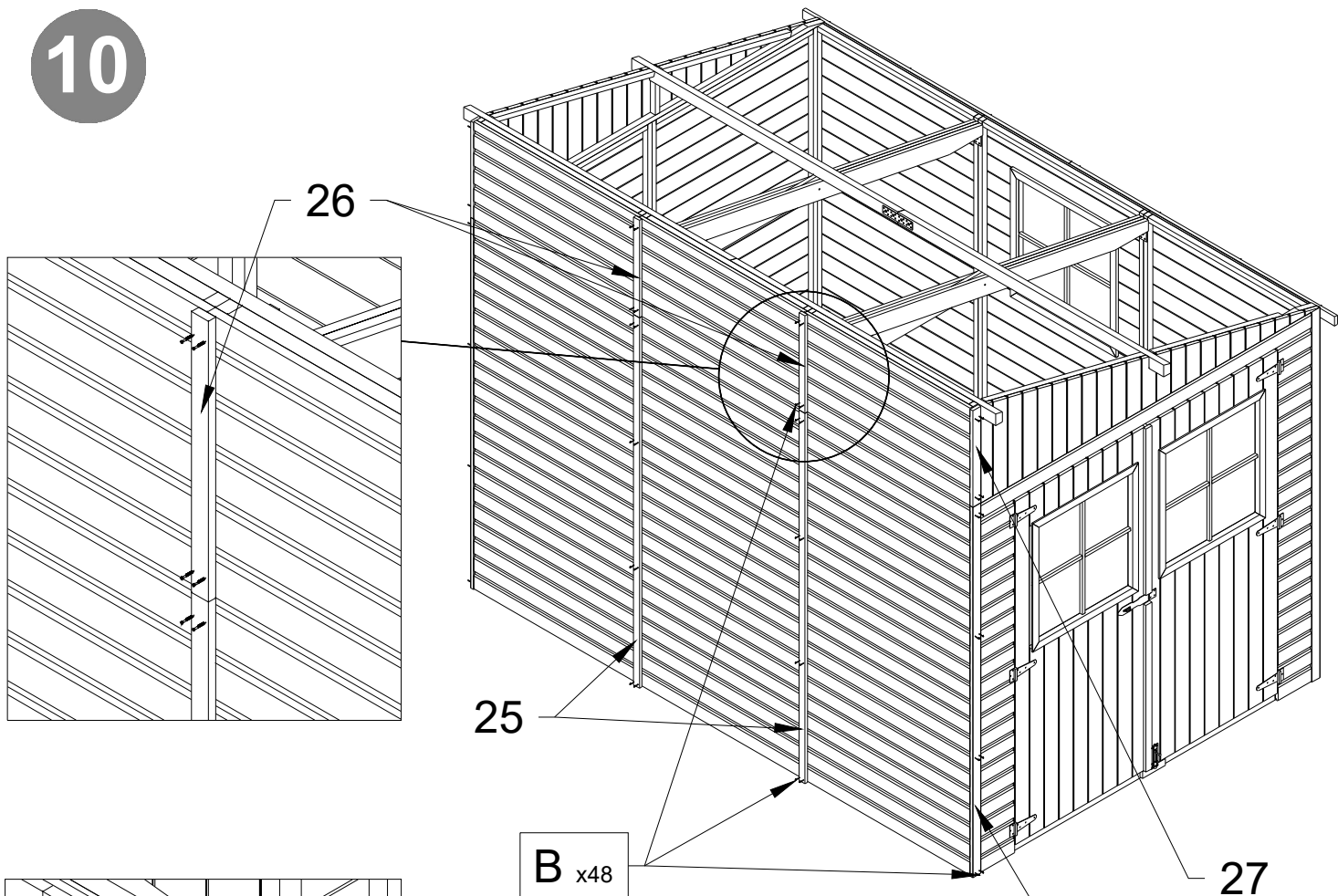

11

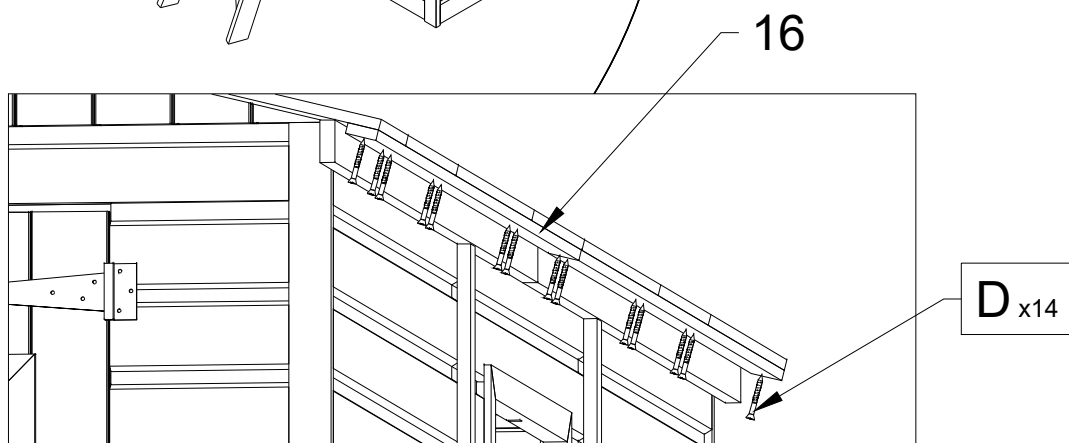
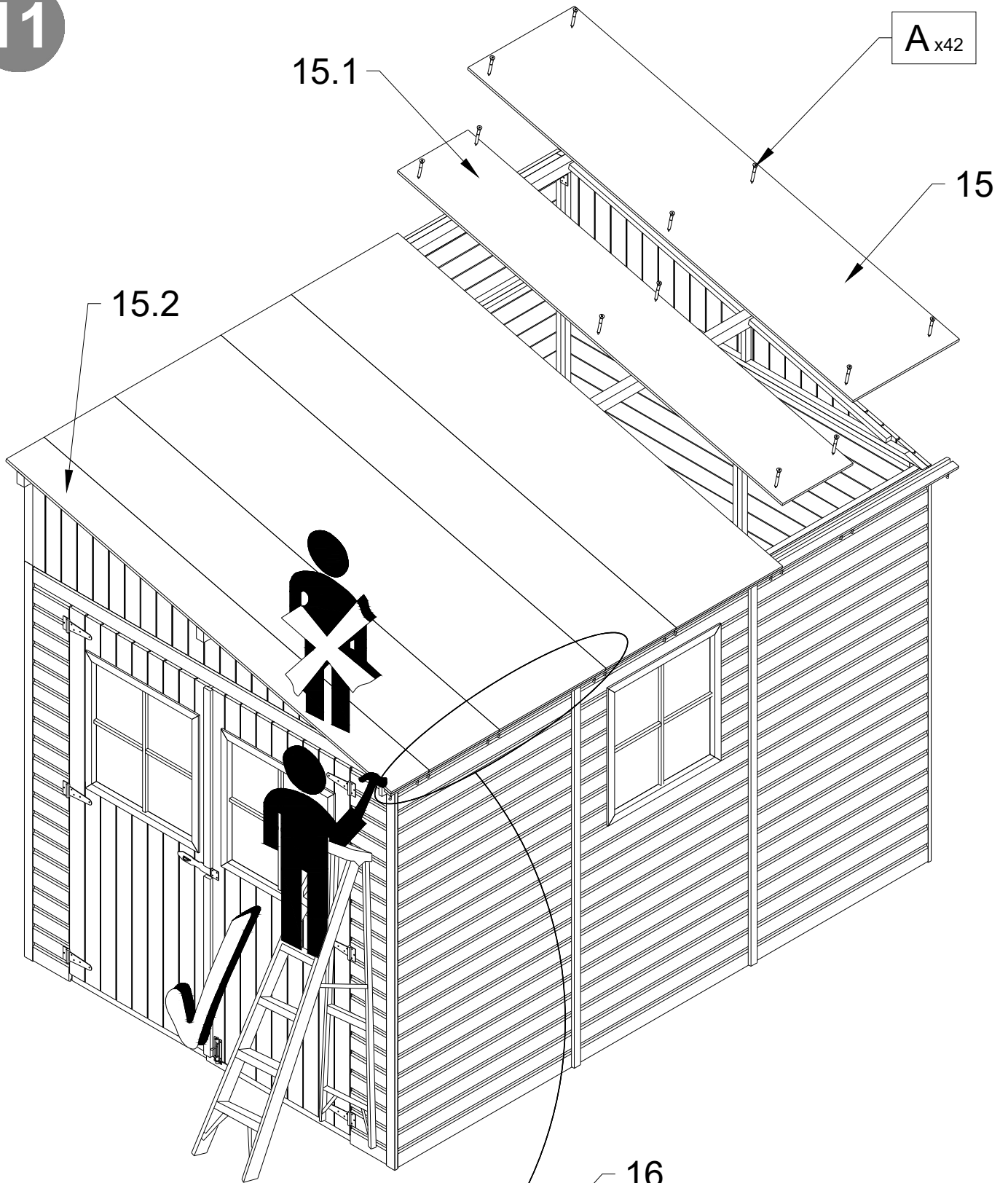

12

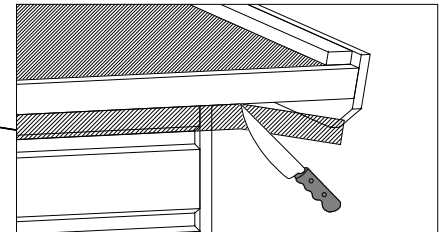
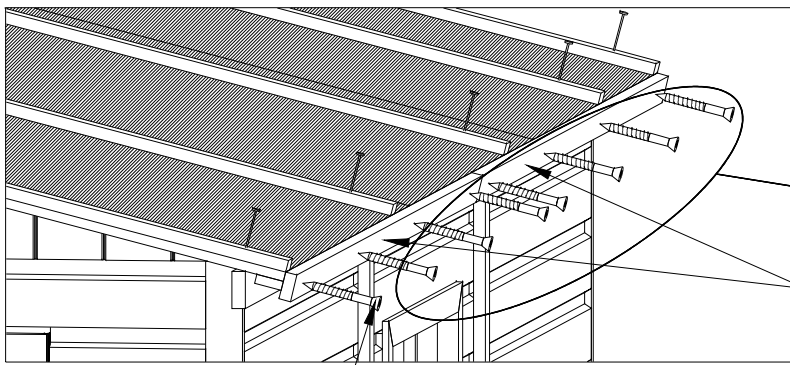

22

B x8

29



18



22

28

22

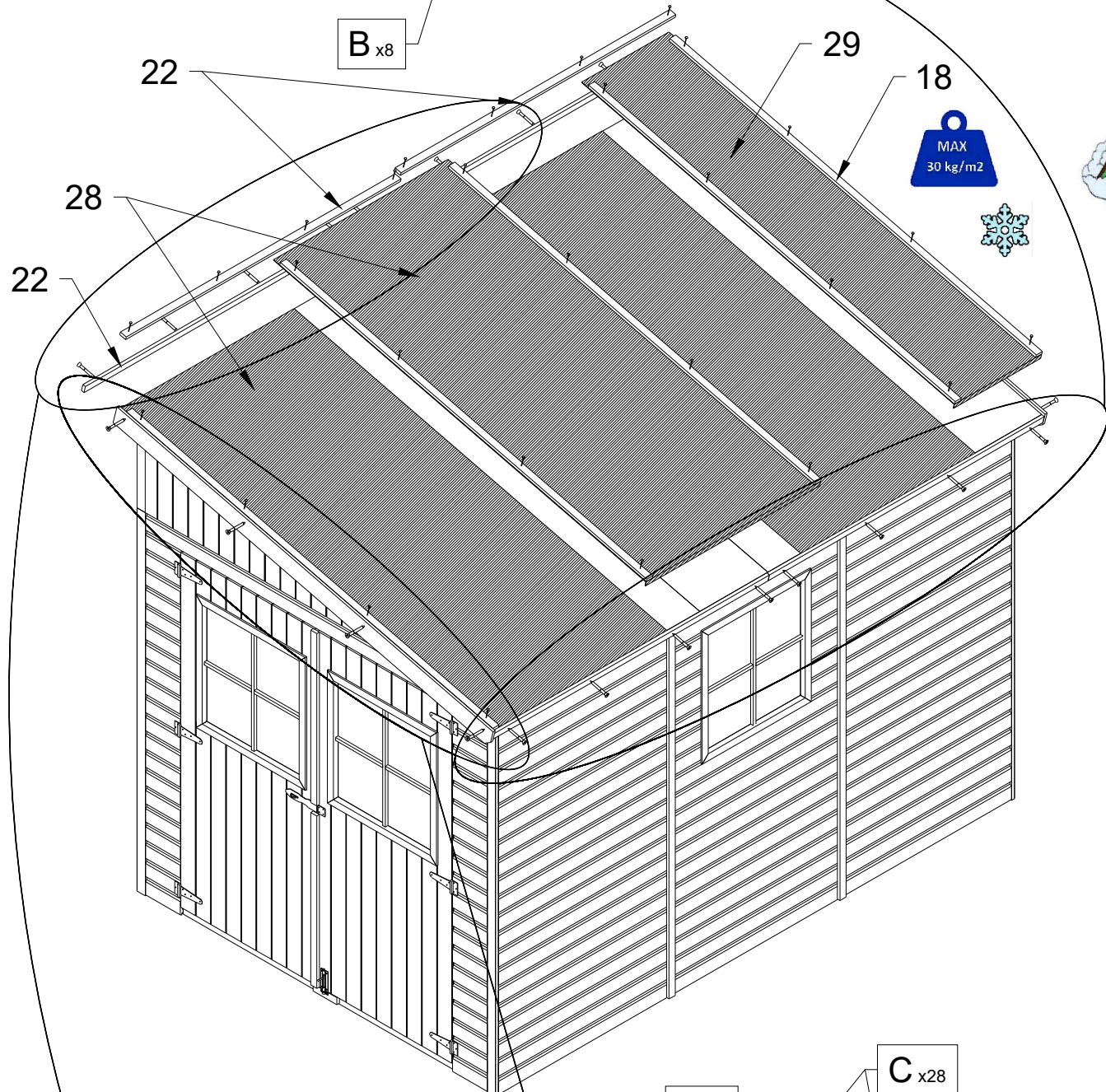

C x28

B x8

17

22

B x8

22

